

YEARS: 2017.5-PRESENT

MAKE: JEEP

MODEL: COMPASS

STYLE: SUV

WARNING: NEVER EXCEED YOUR VEHICLE MANUFACTURER'S RECOMMENDED TOWING CAPACITY
 For more information log onto www.curtmfg.com & for helpful towing tips log onto www.hitchinfo.com

WEIGHT CARRYING:
 TRAILER WEIGHT: 3,500 LBS.
 TONGUE WEIGHT: 350 LBS.

WARNING:
 WE RECOMMEND THE USE OF 18050 STABILIZING STRAPS FOR ALL NON-TRAILER (WHEEL-LESS) LOADS. PLEASE SEE THE CURT CATALOG OR VISIT US ONLINE AT WWW.CURTMFG.COM FOR FURTHER INFORMATION.

PRO INSTALL TIME: 45 MIN.
NOVICE INSTALL TIME: 90 MIN.

IF YOU ARE HESITANT TO UNDERTAKE THIS TASK ON YOUR OWN, CONTACT AN AUTHORIZED CURT INSTALLER FOR ADDITIONAL ASSISTANCE.

INSTALLATION TIPS:

- BEFORE YOU BEGIN INSTALLATION, READ ALL INSTRUCTIONS THOROUGHLY.
- TO EASE INSTALLATION, 2 PEOPLE MAY BE REQUIRED.
- USING PROPER TOOLS WILL GREATLY IMPROVE THE QUALITY OF THE INSTALL AND REDUCE THE TIME REQUIRED.
- NEED HELP OR HAVE SOME QUESTIONS? CALL TECHNICAL SUPPORT AT 800.798.0813



INSTALLATION REQUIRES:

RATCHET	TORQUE WRENCH	6" SOCKET EXTENSION
13mm 15mm 3/4" SOCKET	T30 TORXBIT SOCKET	PLIERS
AVIATION SHEARS	SAFETY GLASSES	DIE GRINDER
TAPE MEASURE	MARKER	MASKING TAPE

LEVEL OF DIFFICULTY: CHALLENGING

EASY	MODERATE	CHALLENGING
PART REMOVAL	LOWER/REMOVE EXHAUST AND REMOVE HEAT SHIELD	
TRIM	TRIM LOWER BUMPER COVER AND HEAT SHIELD	
ENLARGE (2) HOLES FOR HARDWARE ACCESS	ENLARGE (2) HOLES FOR HARDWARE ACCESS	
FISHWIRE (6) FASTENERS	FISHWIRE (6) FASTENERS	

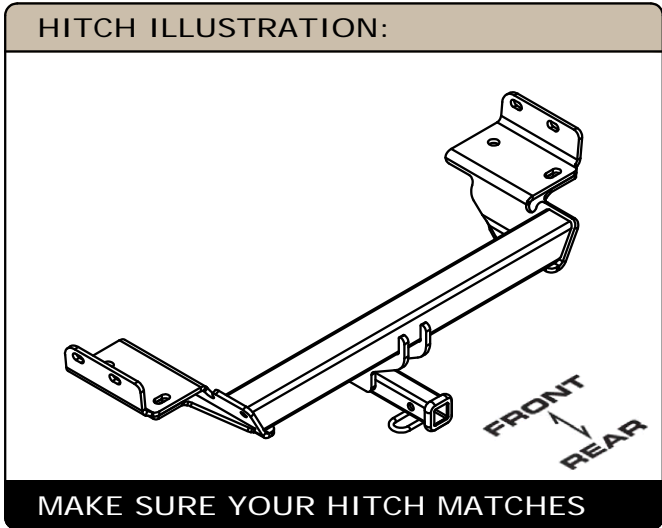

SCAN FOR MORE INFO

PERIODICALLY CHECK THIS RECEIVER HITCH TO ENSURE ALL FASTENERS ARE TIGHT AND ALL STRUCTURAL COMPONENTS ARE SOUND
 CURT Manufacturing LLC. warrants this product to be free of defects in material and/or workmanship at the time of retail purchase by the original purchaser. If the product is found to be defective, CURT Manufacturing LLC. may repair or replace the product at their option, when the product is returned, prepaid, with proof of purchase. Alteration to, misuse of, or improper installation of this product voids the warranty. CURT Manufacturing LLC.'s liability is limited to repair or replacement of products found to be defective, and specifically excludes liability for incidental or consequential loss or damage.
 For more information log onto www.curtmfg.com
 This product complies with safety specifications and requirements for connecting devices and towing systems of the state of New York, V.E.S.C.Regulation V-5 and SAE J684.

INSTALLATION WALKTHROUGH:

Parts List			
ITEM	QTY	PART NUMBER	DESCRIPTION
1	6	CM-SP10	.250 x 1.00 x 2.50" SQUARE HOLE SPACER
2	6	1/2-13 x 1 3/4, GR8	CARRIAGE BOLT
3	6	HFN 1213, GR8	HEX FLANGE NUT
4	6	1_2 FISHWIRE	1/2" FISHWIRE
5	2	M8 - 1.25 x 45 TAP BOLT	TAP BOLT

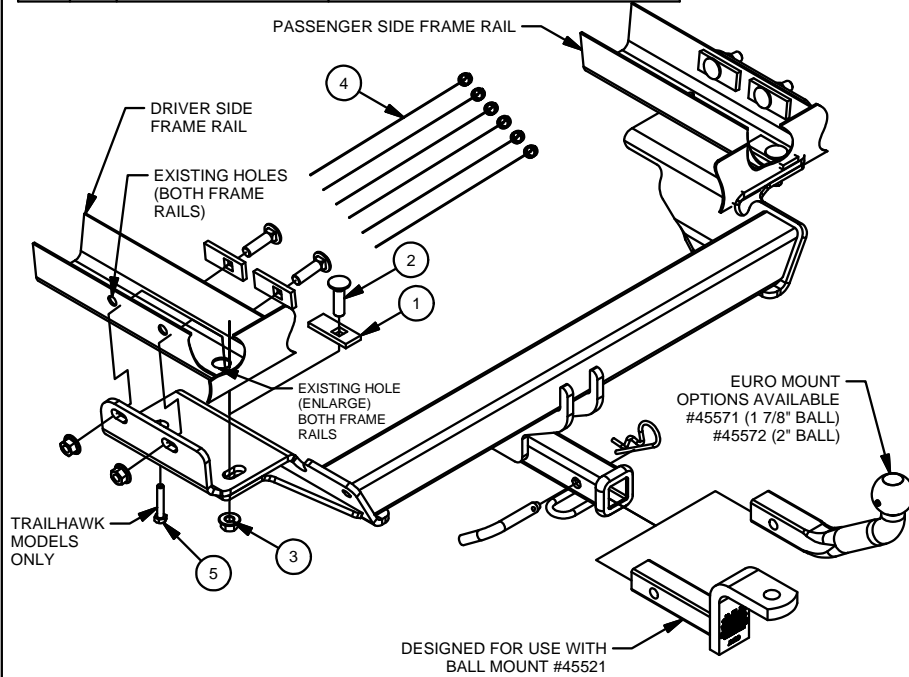

FRONT
↕
REAR

FISHWIRE TECHNIQUE
 INSERT COILED END OF FISHWIRE TOOL THROUGH HITCH MOUNTING HOLE IN VEHICLE FRAME RAIL AND OUT THE ACCESS HOLE. PASS COILED END OF FISHWIRE THROUGH SPACER AND THREAD BOLT INTO COIL. KINK WIRE TO KEEP SPACER SEPARATE FROM BOLT AS SHOWN. PULL FISHWIRE, SPACER, AND BOLT THROUGH FRAME AND OUT MOUNTING HOLE. USE FISHWIRE TO GUIDE HITCH DURING MOUNTING AND PREVENT LOSS OF BOLT / SPACER INSIDE FRAME RAIL.

NOTE: SOME VEHICLES MAY FISHWIRE THROUGH END OF FRAME

REVERSE PULL FISHWIRE TECHNIQUE
 ATTACH FISHWIRE TO CARRIAGE BOLT AND SLIDE SPACER ONTO FISHWIRE. PUSH THE BOLT THRU THE HOLE FOLLOWED BY THE SPACER (AS SHOWN). PULL BOLT BACK INTO POSITION, PROTRUDING FROM THE FRAME.

1. Using a T30 Torq bit, remove the (2) screws attaching the bumper fascia to the body mounts. Save for re-installation later.
 Tow hook equipped models: Remove the (6) 14mm hex bolts from vehicle frame and use to attach hitch. Follow steps 2, 3, 5, 6, 8 and 9.

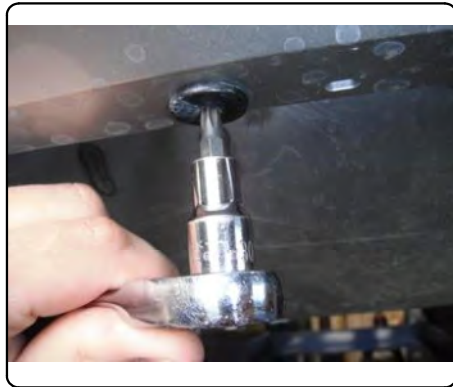

2. Use a 13mm socket to remove the (1) nut on each of the (2) rearward most exhaust hanger brackets. NOTE: Support the exhaust before removing the nuts to prevent damage to the exhaust.
TIP: Temporarily removing the exhaust will ease installation of the hitch. Remove by loosening the nut at the bolted connection in the middle of the vehicle with a 15mm socket.

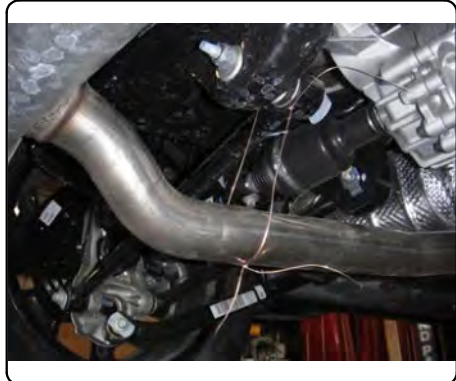

INSTALLATION WALKTHROUGH:

3. Use the 13mm socket to remove the (3) sheet metal nuts holding the heat shield in position. Remove the heat shield and trim the exhaust attachment tabs from it. Re-install heat shield center onto vehicle.

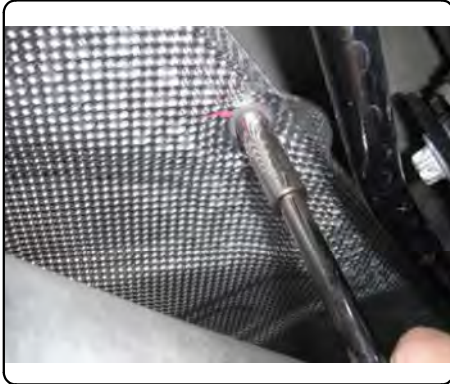

4. Remove the (6) plastic hole covers if present and using a die grinder, enlarge the rearward most holes in the bottom of the frame to allow the supplied carriage bolts and spacers to pass through. Fishwire all (6) 1/2" carriage bolts and CM-SP10 spacers into the mounting positions as shown in the diagram above.

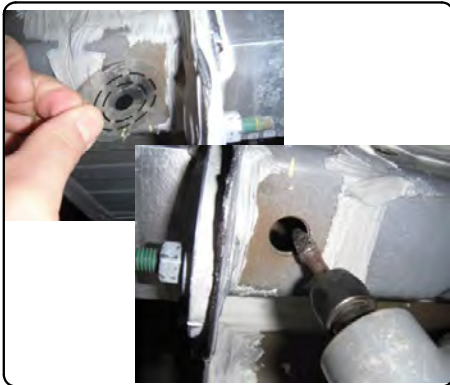

5. Using tape, a marker, and measuring tape, locate the center of the vehicle and mark a 2 1/2" side to side and 2 5/8" lengthwise cutout. Using a tin snips or aviation shears, trim out the area marked. NOTE: These dimensions are reference only, make sure to check hitch location on vehicle prior to trimming.

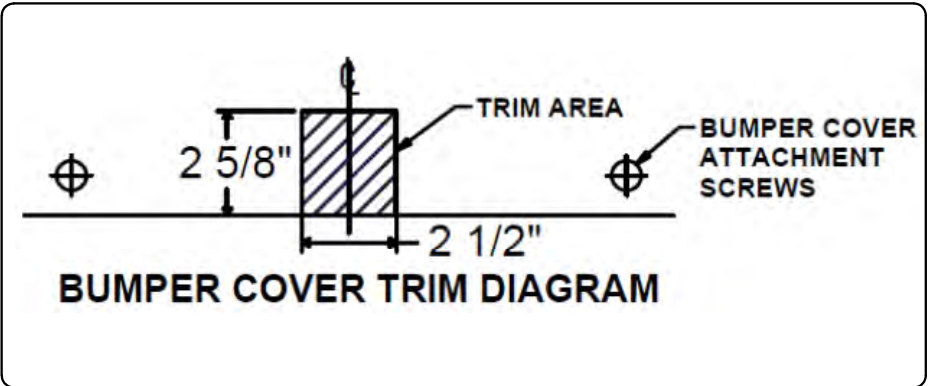

6. With a pliers, bend the (2) small locator tabs flat on each exhaust bracket or remove entirely. Reinstall the exhaust hanger, replace the factory hardware with an M8 tap bolt on each side.



INSTALLATION WALKTHROUGH:

7. Thread fishwires into the hitch mounting holes and raise the hitch into mounting position with the main body on the rearward side of the bumper fascia body mounts. Pull downward on the rear bumper cover +5" to accomplish getting the hitch in position. Remove the fishwires and install the (6) 1/2" hex flange nuts provided.



8. Torque all 1/2" fasteners to 110 lb-ft.
Torque all M14 fasteners to 126 lb-ft.

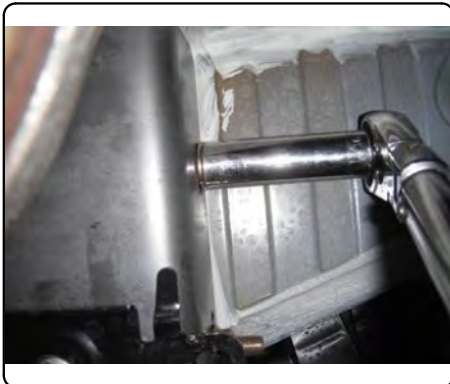

9. Reinstall or raise exhaust back into position and reinstall the flange nuts removed in step 2. Reinstall the rear bumper cover screws removed in step 1.

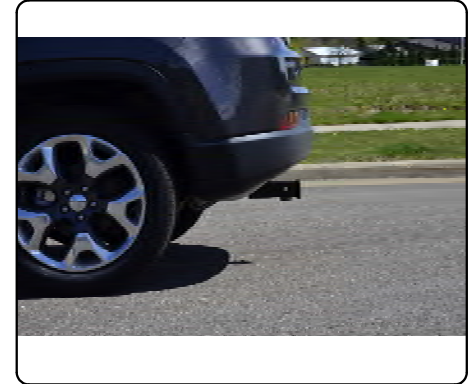

TOWING SAFETY INFORMATION

Gross Trailer Weight / GTW

The Gross Trailer Weight is the weight of the trailer & cargo. Measure this by putting the fully loaded trailer on a vehicle scale.

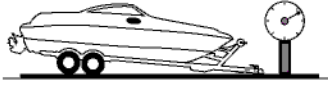

Tongue Weight / TW

The downward force that is exerted on the hitch ball by the coupler. The tongue weight will vary depending on where the load is positioned in relationship to the trailer axle(s). To measure the tongue weight, use either a commercial scale or a bathroom scale with the coupler at towing height. When using a bathroom scale with heavier tongue weights, use the method shown and multiply the scale reading by 3.

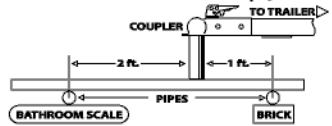

Weight Carrying / WC

The total weight of both the trailer and the cargo inside. Never exceed the weight capacity of your trailer hitch.

Weight Distribution / WD

Used to balance the weight of the cargo between the front and rear wheels throughout the trailer, allowing for better steering, braking, and level riding.



Sway Control

A device used to reduce the lateral movements of the trailer that are caused by the wind. This works in conjunction with a weight distribution hitch. Do not use this on a class 1 or 2 hitch, or with surge brakes.

How Much Can You Safely Tow?

TONGUE WEIGHT (lb)	1000	2000	3000	4000	5000	6000	7000	8000	10,000	12,000
Tongue weight should be about 10 to 15 percent of the gross trailer weight.										
TRAILER TYPE	<div style="display: flex; justify-content: space-between;"> CLASS 1 CLASS 2 CLASS 3 CLASS 4 CLASS 5 </div>									
Camper	11'	12'	13'	14'	15'	16'				
lbs.	1100	1200	1300	1400	1500	1600				
Vacation	18'	19'	20'	22'	24'	26'	28'	30'	32'	
lbs.	2100	2400	2700	3000	3300	3600	3900	4200	4500	4800
Vacation	18'	19'	20'	22'	24'	26'	28'	30'	32'	
lbs.	2800	3200	3600	4000	4400	4800	5200	5600	6000	6400
5th Wheel										

Refer to owner's manual for towing capabilities and limitations.

Ball Mount

The ball mount is placed inside the opening of the receiver hitch which is mounted to the vehicle. Make sure a hitch pin and clip is properly securing the ball mount to the receiver hitch before you begin towing.

- A: Rise. B: Drop. C: Hole Size. D: Length.

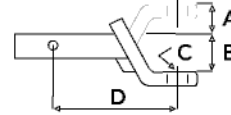

Trailer Ball

The connection from the hitch to the trailer. There are many factors that determine the correct hitch ball:

- Number one is the hitch ball's gross trailer weight rating.
- The mounting platform must be at least 3/8" thick.
- The hole diameter must not be more than 1/16" larger than the threaded shank.
- Every time you tow, check the nut and lock washer to make sure they are fastened securely.
- A: Ball Dia. B: Shank Length. C: Shank Dia. D: Shank Rise.

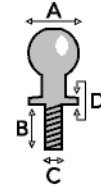

Coupler

The component that is placed over the trailer ball to connect the vehicle to the trailer. Be sure that the coupler size matches the size of the hitch ball and that the coupler handle is securely fastened. To determine what size hitch ball you need for your application you will need to know the size of coupler that is on the trailer. Be sure your coupler is properly adjusted to the ball you are using.

NOTE: For added security the use of safety devices such as Coupler Safety Pins and Locks is strongly recommended.

Safety Chains

Safety chains are a requirement and should be crossed under the tongue of the trailer so that the tongue will not drop to the road if it becomes separated from the hitch. Always leave enough slack so you can turn. Never allow the safety chains to drag on the ground and never attach the chains to the bumper.

Trailer Classification: Safety Chain Breaking Force - Minimum

Class 1: 2,000 lbs. (8.9 kN)

Class 2: 3,500 lbs. (15.6 kN)

Class 3: 5,000 lbs. (22.2 kN)

The strength rating of each length of safety chain or its equivalent and its attachments shall be equal to or exceed in minimum breaking force the GVWR (Gross Vehicle Weight Rating) of the trailer.

Electrical

Trailer lights, Electric Brakes, Break-away systems - Every time you tow, be sure to check that all components are working properly.

Wiring identification by color:

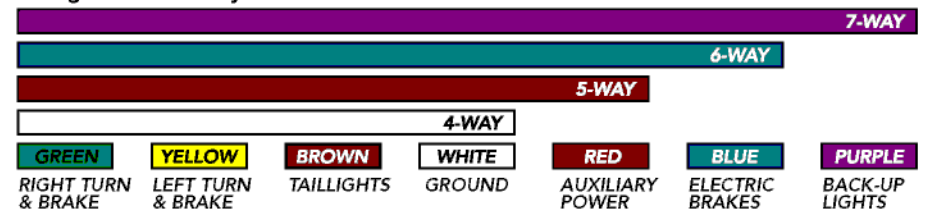

CURT DISCLAIMER: WIRING COLOR SHOWN WORK IN CONJUNCTION WITH CURT MANUFACTURING PRODUCTS.

12174

JEEP COMPASS

4/17/2018

GROSS LOAD CAPACITY WHEN USED AS A WEIGHT CARRYING HITCH: 3,500 LBS. TRAILER WEIGHT & 350 LBS. TONGUE WEIGHT.

WARNING: ALL NON-TRAILER LOADS APPLIED TO THIS PRODUCT MUST BE SUPPORTED BY 18050 STABILIZING STRAPS.

WARNING: ** FAILURE TO PROPERLY SUPPORT NON-TRAILER LOADS WILL VOID PRODUCT WARRANTY **

WARNING: *** DO NOT EXCEED VEHICLE MANUFACTURER'S RECOMMENDED TOWING CAPACITY ***

FOR MORE INFORMATION LOG ONTO WWW.CURTMFG.COM

HAVING INSTALLATION QUESTIONS? CALL TECHNICAL SUPPORT AT 1-800-798-0813



Parts List			
ITEM	QTY	PART NUMBER	DESCRIPTION
1	6	CM-SP10	.250 x 1.00 x 2.50" SQUARE HOLE SPACER
2	6	1/2-13 x 1 3/4, GR8	CARRIAGE BOLT
3	6	HFN 1213, GR8	HEX FLANGE NUT
4	6	1_2 FISHWIRE	1/2" FISHWIRE
5	2	M8 - 1.25 x 45 TAP BOLT	TAP BOLT

TOOLS REQUIRED
RATCHET
TORQUE WRENCH
SAFETY GLASSES
T30 TORQ BIT
13mm, 15mm, 3/4" SOCKETS
MASKING TAPE
TAPE MEASURE
AVIATION SHEARS
DIE GRINDER
PLIERS
MARKER
6" SOCKET EXTENSION

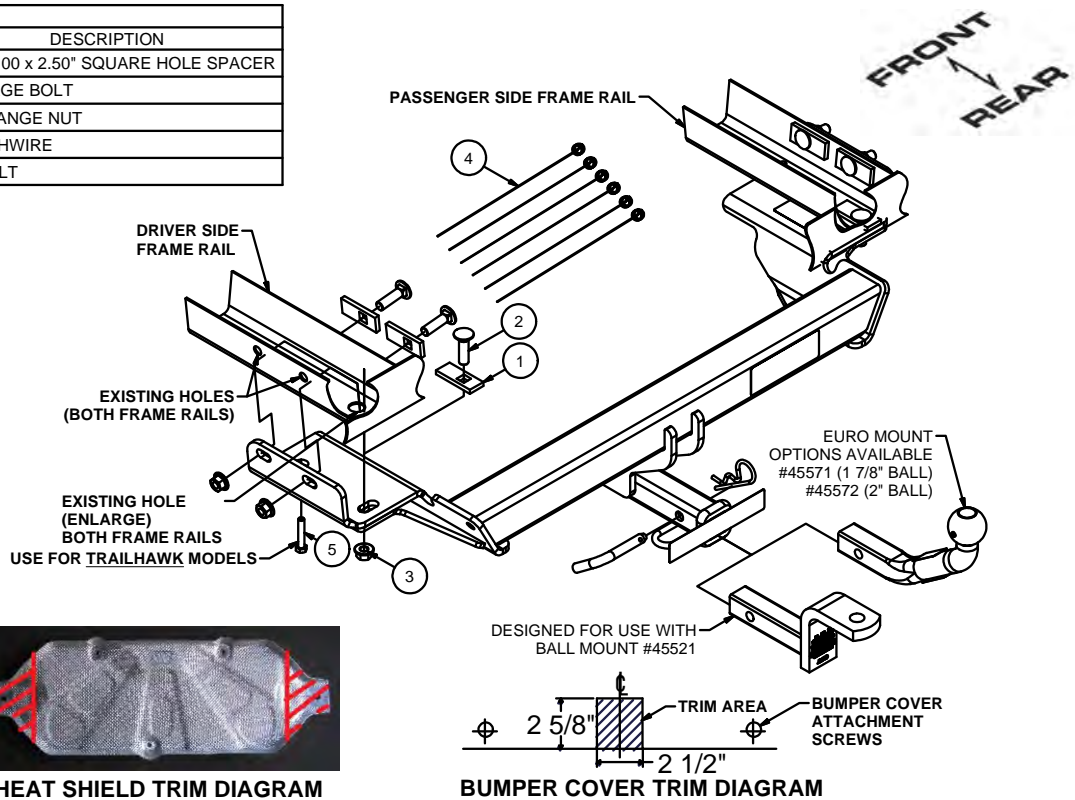

HEAT SHIELD TRIM DIAGRAM

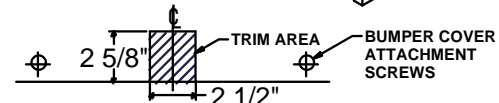

BUMPER COVER TRIM DIAGRAM

HITCH WEIGHT: 42 LBS.

INSTALL TIME

PROFESSIONAL: 45 MINUTES

NOVICE (DIY): 90 MINUTES

INSTALL NOTES:

- REMOVE/TRIM HEAT SHIELD
- FISHWIRE HARDWARE
- ENLARGE HOLES
- LOWER/MODIFY EXHAUST
- TRIM FASCIA

INSTALLATION STEPS

- Using a T30 Torq bit, remove the (2) screws attaching the bumper fascia to the body mounts. Save for re-installation later.
 - Use a 13mm socket to remove the (1) nut on each of the (2) rearward most exhaust hanger brackets. NOTE: Support the exhaust before removing the nuts to prevent damage to the exhaust.
- TIP: Temporarily removing the exhaust will ease installation of the hitch. Remove by loosening the nut at the bolted connection in the middle of the vehicle with a 15mm socket.
- Use the 13mm socket to remove the (3) sheet metal nuts holding the heat shield in position. Remove the heat shield and trim the exhaust attachment tabs from it. Re-install heat shield center onto vehicle.
- Tow hook equipped models: Remove the (6) 14mm hex bolts from vehicle frame and use to attach hitch. Follow steps 5, 6, 8 and 9.
- Remove the (6) plastic hole covers if present and using a die grinder, enlarge the rearward most holes in the bottom of the frame to allow the supplied carriage bolts and spacers to pass through. Fishwire all (6) 1/2" carriage bolts and CM-SP10 spacers into the mounting positions as shown in the diagram above.
 - Using tape, a marker, and measuring tape, locate the center of the vehicle and mark a 2 1/2" side to side and 2 5/8" lengthwise cutout. Using a tin snips or aviation shears, trim out the area marked. NOTE: These dimensions are reference only, make sure to check hitch location on vehicle prior to trimming.
 - With a pliers, bend the (2) small locator tabs flat on each exhaust bracket or remove entirely. Reinstall the exhaust hanger, replace the factory hardware with an M8 tap bolt on each side.
 - Thread fishwires into the hitch mounting holes and raise the hitch into mounting position with the main body on the rearward side of the bumper fascia body mounts. Pull downward on the rear bumper cover +5" to accomplish getting the hitch in position. Remove the fishwires and install the (6) 1/2" hex flange nuts provided.
 - Torque all 1/2" fasteners to 110 lb-ft. Torque M14 fasteners to 126 lb-ft.
 - Reinstall or raise exhaust back into position and reinstall the flange nuts removed in step 2. Reinstall the rear bumper cover screws removed in step 1.

PERIODICALLY CHECK THIS RECEIVER HITCH TO ENSURE THAT ALL FASTENERS ARE TIGHT AND THAT ALL STRUCTURAL COMPONENTS ARE SOUND.



Scan
for more
information

CURT Manufacturing LLC., warrants this product to be free of defects in material and/or workmanship at the time of retail purchase by the original purchaser. If the product is found to be defective, CURT Manufacturing LLC., may repair or replace the product, at their option, when the product is returned, prepaid, with proof of purchase. Alteration to, misuse of, or improper installation of this product voids the warranty. CURT Manufacturing LLC.'s liability is limited to repair or replacement of products found to be defective, and specifically excludes liability for incidental or consequential loss or damage.

This product complies with safety specifications and requirements for connecting devices and towing systems of the state of New York, V.E.S.C.Regulation V-5 and SAE J684.