

YEARS: 2018-PRESENT

MAKE: TOYOTA

MODEL: CAMRY

STYLE: SEDAN

WARNING: NEVER EXCEED YOUR VEHICLE MANUFACTURER'S RECOMMENDED TOWING CAPACITY
 For more information log onto www.curtmfg.com & for helpful towing tips log onto www.hitchinfo.com

WEIGHT CARRYING:
 TRAILER WEIGHT: 3,500 LBS.
 TONGUE WEIGHT: 350 LBS.

WARNING:
 WE RECOMMEND THE USE OF 18050 STABILIZING STRAPS FOR ALL NON-TRAILER (WHEEL-LESS) LOADS. PLEASE SEE THE CURT CATALOG OR VISIT US ONLINE AT WWW.CURTMFG.COM FOR FURTHER INFORMATION.

PRO INSTALL TIME: 60 MIN.
NOVICE INSTALL TIME: 120 MIN.

IF YOU ARE HESITANT TO UNDERTAKE THIS TASK ON YOUR OWN, CONTACT AN AUTHORIZED CURT INSTALLER FOR ADDITIONAL ASSISTANCE.

INSTALLATION REQUIRES:

 10mm 12mm 13mm SOCKET	 17mm 19mm SOCKET	 RATCHET
 TORQUE WRENCH	 DIE GRINDER	 ROTARY TOOL
 POWER DRILL	 DRILL BIT 9/16"	 MASKING TAPE
 TAPE MEASURE	 SAFETY GLASSES	

INSTALLATION TIPS:

- BEFORE YOU BEGIN INSTALLATION, READ ALL INSTRUCTIONS THOROUGHLY.
- TO EASE INSTALLATION, 2 PEOPLE MAY BE REQUIRED.
- USING PROPER TOOLS WILL GREATLY IMPROVE THE QUALITY OF THE INSTALL AND REDUCE THE TIME REQUIRED.
- NEED HELP OR HAVE SOME QUESTIONS? CALL TECHNICAL SUPPORT AT 800.798.0813

LEVEL OF DIFFICULTY: CHALLENGING

EASY	MODERATE	CHALLENGING
 PART REMOVAL	TEMPORARILY REMOVE EXHAUST HANGERS	
 TRIM	UNDERBODY PANEL TRIMMING REQUIRED	
 HOLE ENLARGEMENT REQUIRED	HOLE ENLARGEMENT REQUIRED	
 DRILLING REQUIRED ON HYBRID AND 6 CYLINDER MODELS	DRILLING REQUIRED ON HYBRID AND 6 CYLINDER MODELS	

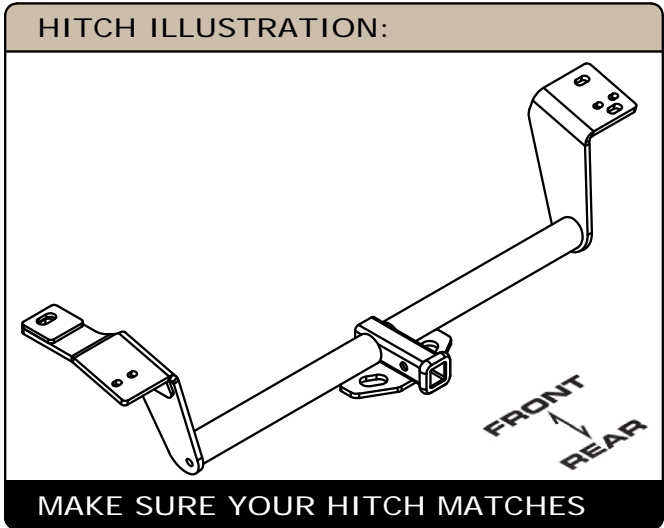

SCAN FOR MORE INFO

PERIODICALLY CHECK THIS RECEIVER HITCH TO ENSURE ALL FASTENERS ARE TIGHT AND ALL STRUCTURAL COMPONENTS ARE SOUND
 CURT Manufacturing LLC. warrants this product to be free of defects in material and/or workmanship at the time of retail purchase by the original purchaser. If the product is found to be defective, CURT Manufacturing LLC. may repair or replace the product at their option, when the product is returned, prepaid, with proof of purchase. Alteration to, misuse of, or improper installation of this product voids the warranty. CURT Manufacturing LLC.'s liability is limited to repair or replacement of products found to be defective, and specifically excludes liability for incidental or consequential loss or damage.
 For more information log onto www.curtmfg.com
 This product complies with safety specifications and requirements for connecting devices and towing systems of the state of New York, V.E.S.C.Regulation V-5 and SAE J684.

INSTALLATION WALKTHROUGH:

Parts List			
ITEM	QTY	PART NUMBER	DESCRIPTION
1	2	M12 x 1.25 x 45	HEX BOLT
2	2	1/2"	CONICAL TOOTHED WASHER
3	3	1/2-13 x 1 1/2, GR8	CARRIAGE BOLT
4	3	CM-SP10	.250 x 1.00 x 2.50" SQUARE HOLE SPACER
5	3	HFN 1213, GR8	HEX FLANGE NUT
6	4	M8 - 1.25 x 35 HFB	M8-1.25 x 35 HEX FLANGE BOLT
7	3	1_2 FISHWIRE	1/2" FISHWIRE
8	4	1_4 WASHER	1/4" WASHER EXTRA THICK

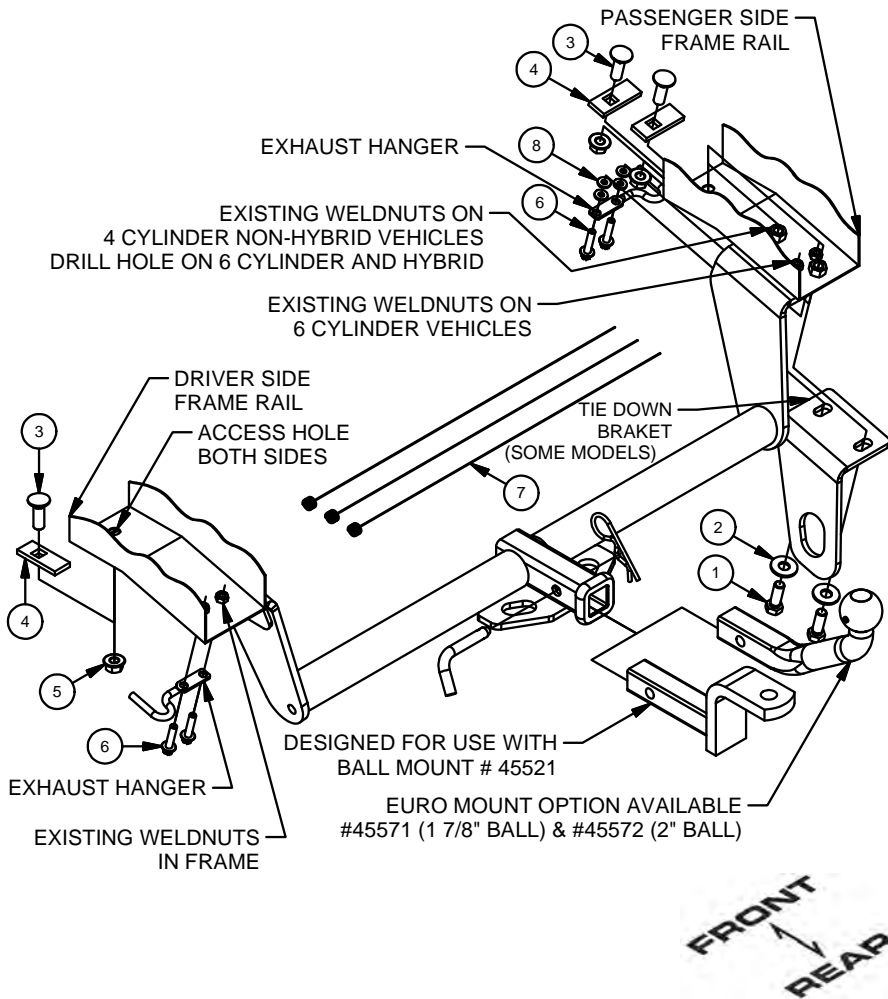

1. Lower exhaust by removing (2) rubber isolators per muffler and (1) rubber isolator forward of the muffler. **On 4 cylinder non-hybrid models** remove tie down bracket from passenger side frame rail. **On hybrid models** remove rear exhaust hanger from driver side frame rail. **On 6 cylinder models** remove rear exhaust hanger from both frame rails. Save for reinstallation. **NOTE:** Support exhaust to prevent damage.



2. Remove heat shields and trim using HEAT SHIELD TRIM DIAGRAM for reference and reinstall. **4 cylinder hybrid and non-hybrid models:** remove plastic underbody panel and trim using PANEL TRIM DIAGRAM for reference.

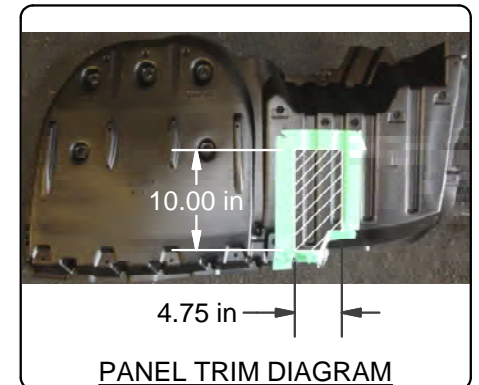
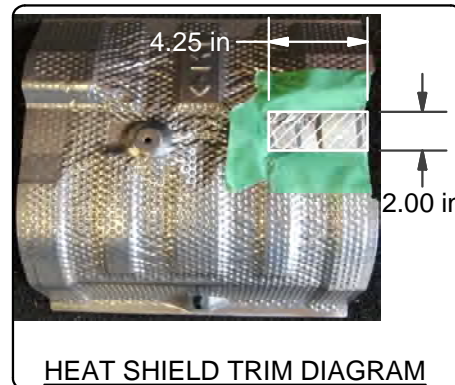

INSTALLATION WALKTHROUGH:

3. Enlarge access hole in driver side frame rail. Reverse fishwire (1) 1/2" carriage bolt and CM-SP10 spacer into the enlarged hole.
On hybrid and 6 cylinder models: enlarge access hole in passenger side frame rail. Temporarily install hitch and mark holes in passenger side frame rail for drilling. Lower hitch and drill holes marked on frame. Fishwire (2) 1/2" carriage bolts and CM-SP10 spacers into drilled holes.

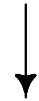
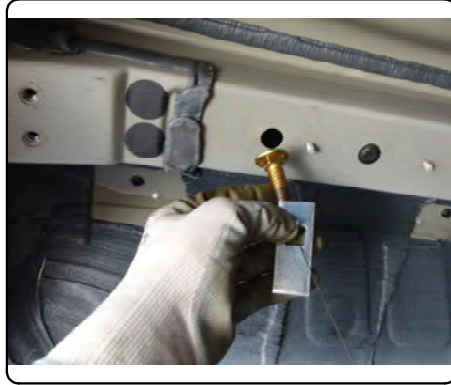

4. Reinstall plastic underbody panel if removed in Step 2. Raise hitch into position and secure using the provided hardware while reinstalling any removed exhaust hangers. Torque M12 hardware to 79 ft-lbs, M8 hardware to 23 ft-lbs, 1/2" hardware to 110 ft-lbs.
On 6 cylinder models: reinstall the passenger side exhaust hanger placing (2) washers per bolt between the exhaust hanger and the hitch.



For more information log onto www.curtmfg.com

TOWING SAFETY INFORMATION

Gross Trailer Weight / GTW

The Gross Trailer Weight is the weight of the trailer & cargo. Measure this by putting the fully loaded trailer on a vehicle scale.



Tongue Weight / TW

The downward force that is exerted on the hitch ball by the coupler. The tongue weight will vary depending on where the load is positioned in relationship to the trailer axle(s). To measure the tongue weight, use either a commercial scale or a bathroom scale with the coupler at towing height. When using a bathroom scale with heavier tongue weights, use the method shown and multiply the scale reading by 3.

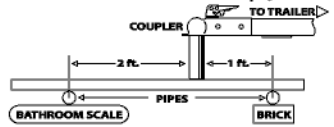

Weight Carrying / WC

The total weight of both the trailer and the cargo inside. Never exceed the weight capacity of your trailer hitch.

Weight Distribution / WD

Used to balance the weight of the cargo between the front and rear wheels throughout the trailer, allowing for better steering, braking, and level riding.



Sway Control

A device used to reduce the lateral movements of the trailer that are caused by the wind. This works in conjunction with a weight distribution hitch. Do not use this on a class 1 or 2 hitch, or with surge brakes.

How Much Can You Safely Tow?

TONGUE WEIGHT (lb)	1000	2000	3000	4000	5000	6000	7000	8000	10,000	12,000
Tongue weight should be about 10 to 15 percent of the gross trailer weight.										
CLASS 1										
CLASS 2										
CLASS 3										
CLASS 4										
CLASS 5										
TRAILER TYPE										
Camper	11'	12'	13'	14'	15'	16'				
lbs.	1100	1200	1300	1400	1500	1600				
Vacation	18'	19'	20'	22'	24'	26'	28'	30'	32'	
lbs.	2100	2400	2700	3000	3300	3600	3900	4200	4500	4800
Vacation	18'	19'	20'	22'	24'	26'	28'	30'	32'	
lbs.	2800	3200	3600	4000	4400	4800	5200	5600	6000	6400
5th Wheel										

Refer to owner's manual for towing capabilities and limitations.

Ball Mount

The ball mount is placed inside the opening of the receiver hitch which is mounted to the vehicle. Make sure a hitch pin and clip is properly securing the ball mount to the receiver hitch before you begin towing.

- A: Rise. B: Drop. C: Hole Size. D: Length.



Trailer Ball

The connection from the hitch to the trailer. There are many factors that determine the correct hitch ball:

- Number one is the hitch ball's gross trailer weight rating.
- The mounting platform must be at least 3/8" thick.
- The hole diameter must not be more than 1/16" larger than the threaded shank.
- Every time you tow, check the nut and lock washer to make sure they are fastened securely.
- A: Ball Dia. B: Shank Length. C: Shank Dia. D: Shank Rise.



Coupler

The component that is placed over the trailer ball to connect the vehicle to the trailer. Be sure that the coupler size matches the size of the hitch ball and that the coupler handle is securely fastened. To determine what size hitch ball you need for your application you will need to know the size of coupler that is on the trailer. Be sure your coupler is properly adjusted to the ball you are using.

NOTE: For added security the use of safety devices such as Coupler Safety Pins and Locks is strongly recommended.

Safety Chains

Safety chains are a requirement and should be crossed under the tongue of the trailer so that the tongue will not drop to the road if it becomes separated from the hitch. Always leave enough slack so you can turn. Never allow the safety chains to drag on the ground and never attach the chains to the bumper.

Trailer Classification: Safety Chain Breaking Force - Minimum

Class 1: 2,000 lbs. (8.9 kN)

Class 2: 3,500 lbs. (15.6 kN)

Class 3: 5,000 lbs. (22.2 kN)

The strength rating of each length of safety chain or its equivalent and its attachments shall be equal to or exceed in minimum breaking force the GVWR (Gross Vehicle Weight Rating) of the trailer.

Electrical

Trailer lights, Electric Brakes, Break-away systems - Every time you tow, be sure to check that all components are working properly.

Wiring identification by color:

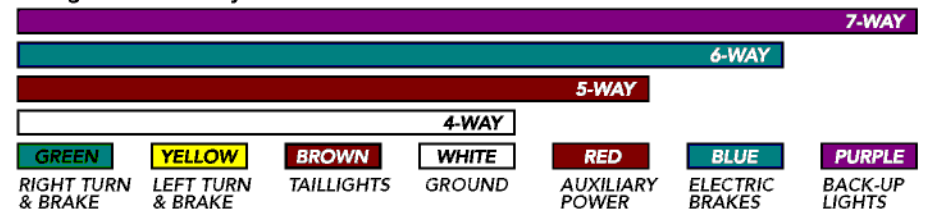

CURT DISCLAIMER: WIRING COLOR SHOWN WORK IN CONJUNCTION WITH CURT MANUFACTURING PRODUCTS.

GROSS LOAD CAPACITY WHEN USED AS A WEIGHT CARRYING HITCH: 3,500 LBS. TRAILER WEIGHT & 350 LBS. TONGUE WEIGHT.

WARNING: ALL NON-TRAILER LOADS APPLIED TO THIS PRODUCT MUST BE SUPPORTED BY 18050 STABILIZING STRAPS.

WARNING: ** FAILURE TO PROPERLY SUPPORT NON-TRAILER LOADS WILL VOID PRODUCT WARRANTY **

WARNING: *** DO NOT EXCEED VEHICLE MANUFACTURER'S RECOMMENDED TOWING CAPACITY ***

FOR MORE INFORMATION LOG ONTO WWW.CURTMFG.COM

HAVING INSTALLATION QUESTIONS? CALL TECHNICAL SUPPORT AT 1-800-798-0813



Parts List			
ITEM	QTY	PART NUMBER	DESCRIPTION
1	2	M12 x 1.25 x 45	HEX BOLT
2	2	1/2"	CONICAL TOOTHED WASHER
3	3	1/2-13 x 1 1/2, GR8	CARRIAGE BOLT
4	3	CM-SP10	.250 x 1.00 x 2.50" SQUARE HOLE SPACER
5	3	HFN 1213, GR8	HEX FLANGE NUT
6	4	M8 - 1.25 x 35 HFB	M8-1.25 x 35 HEX FLANGE BOLT
7	3	1_2 FISHWIRE	1/2" FISHWIRE
8	4	1_4 WASHER	1/4" WASHER EXTRA THICK

TOOLS REQUIRED
10mm, 12mm, 13mm SOCKETS
17mm, 19mm SOCKETS
RATCHET
TORQUE WRENCH
DIE GRINDER
CUTOFF WHEEL
MASKING TAPE
SAFETY GLASSES
TAPE MEASURE
DRILL
9/16" DRILL BIT

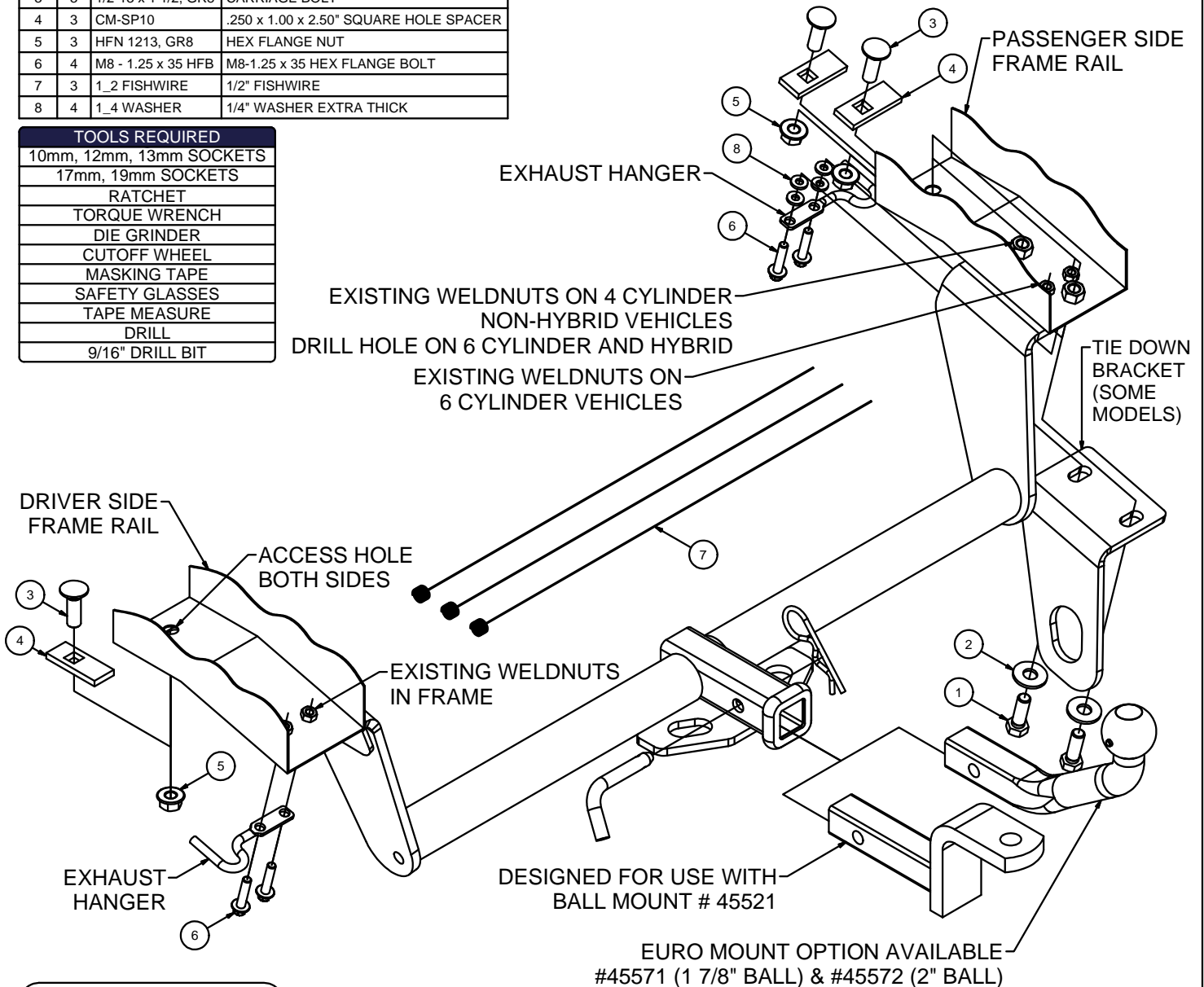

HITCH WEIGHT: 23 LBS.
 INSTALL TIME
 PROFESSIONAL: 60 MINUTES
 NOVICE (DIY): 120 MINUTES
 INSTALL NOTES:
 - TRIMMING REQUIRED
 - DRILLING REQUIRED ON HYBRID AND 6 CYLINDER MODELS

PERIODICALLY CHECK THIS RECEIVER HITCH TO ENSURE THAT ALL FASTENERS ARE TIGHT AND THAT ALL STRUCTURAL COMPONENTS ARE SOUND.



Scan for more information

CURT Manufacturing LLC., warrants this product to be free of defects in material and/or workmanship at the time of retail purchase by the original purchaser. If the product is found to be defective, CURT Manufacturing LLC., may repair or replace the product, at their option, when the product is returned, prepaid, with proof of purchase. Alteration to, misuse of, or improper installation of this product voids the warranty. CURT Manufacturing LLC.'s liability is limited to repair or replacement of products found to be defective, and specifically excludes liability for incidental or consequential loss or damage.

This product complies with safety specifications and requirements for connecting devices and towing systems of the state of New York, V.E.S.C.Regulation V-5 and SAE J684.

HAVING INSTALLATION QUESTIONS? CALL TECHNICAL SUPPORT AT 1-800-798-0813

CONICAL TOOTHED WASHER ORIENTATION DIAGRAM

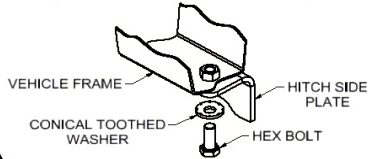

REVERSE PULL FISHWIRE TECHNIQUE

ATTACH FISHWIRE TO CARRIAGE BOLT AND SLIDE SPACER ONTO FISHWIRE. PUSH THE BOLT THRU THE HOLE FOLLOWED BY THE SPACER (AS SHOWN). PULL BOLT BACK INTO POSITION, PROTRUDING FROM THE FRAME.

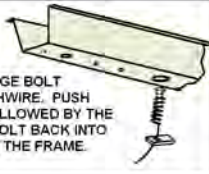

WELDNUT CLEANING

To remove debris from weldnuts in frame, spray lubricant or compressed air into hole. For heavy debris, use a small wire brush. (Be careful not to damage threads).

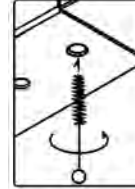

RUBBER ISOLATOR REMOVAL DIAGRAM

This technique can be used if an Exhaust Hanger Removal Pliers is not available.

Using a 5/8" open end wrench, slide the wrench up to the rubber isolator, cradling the hanger rod as shown. Next place the flat edge of a pry bar between the wrench and the hanger stop or hanger rod. Then simply rotate the pry bar toward the wrench to remove the rubber isolator.

Note: Using a spray lubricant or soapy water on the hanger rod and the rubber isolator helps removal.



CONICAL TOOTHED WASHER ORIENTATION DIAGRAM

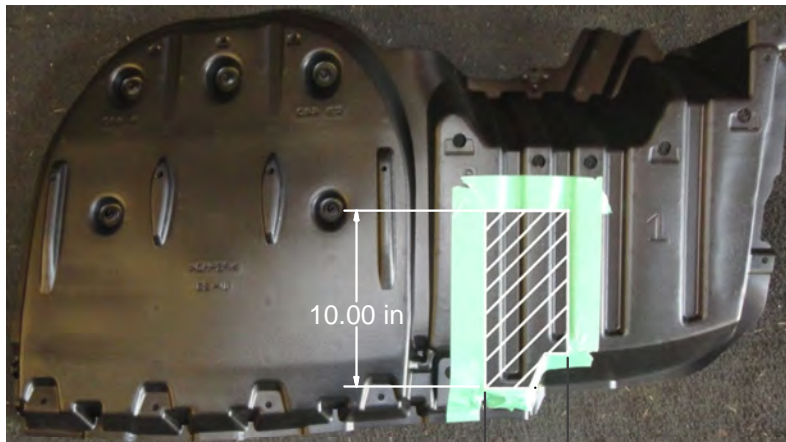
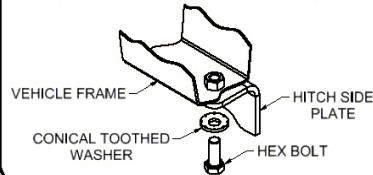

PANEL TRIM DIAGRAM

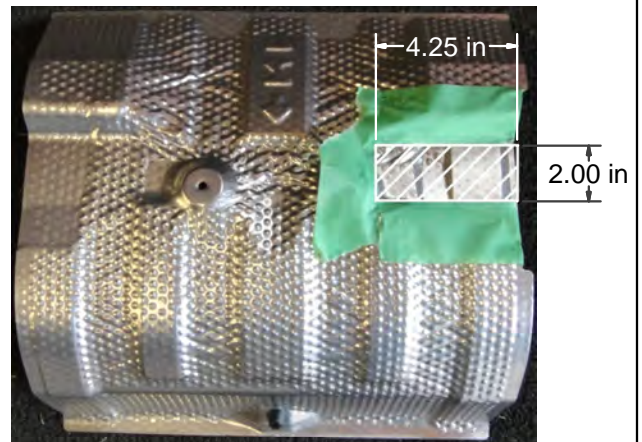

HEAT SHIELD TRIM DIAGRAM

INSTALLATION STEPS

- Lower exhaust by removing (2) rubber isolators per muffler and (1) rubber isolator forward of the muffler. **On 4 cylinder non-hybrid models:** remove tie down bracket from passenger side frame rail. **On hybrid models:** remove rear exhaust hanger from driver side frame rail. **On 6 cylinder models:** remove rear exhaust hanger from both frame rails. Save for reinstallation. **NOTE:** Support exhaust to prevent damage.
- Remove heat shields and trim using HEAT SHIELD TRIM DIAGRAM for reference and reinstall. **On 4 cylinder hybrid and non-hybrid models:** remove plastic underbody panel and trim using PANEL TRIM DIAGRAM for reference.
- Enlarge access hole in driver side frame rail. Reverse fishwire (1) 1/2" carriage bolt and CM-SP10 spacer into enlarged access hole. **On hybrid and 6 cylinder models:** enlarge access hole in passenger side frame rail. Temporarily install hitch and mark holes in passenger side frame rail for drilling. Lower hitch and drill holes marked on frame. Fishwire 1/2" carriage bolts and CM-SP10 spacers into drilled holes.
- Reinstall plastic underbody panel if removed in Step 2. Raise hitch into position and secure using the provided hardware and reinstalling any removed exhaust hangers. Torque M12 hardware to 79 ft-lbs, M8 hardware to 23 ft-lbs, 1/2" hardware to 110 ft-lbs. **On 6 cylinder models:** reinstall the passenger side exhaust hanger placing (2) washers per bolt between the exhaust hanger and the hitch.

PERIODICALLY CHECK THIS RECEIVER HITCH TO ENSURE THAT ALL FASTENERS ARE TIGHT AND THAT ALL STRUCTURAL COMPONENTS ARE SOUND.

CURT Manufacturing LLC., warrants this product to be free of defects in material and/or workmanship at the time of retail purchase by the original purchaser. If the product is found to be defective, CURT Manufacturing LLC., may repair or replace the product, at their option, when the product is returned, prepaid, with proof of purchase. Alteration to, misuse of, or improper installation of this product voids the warranty. CURT Manufacturing LLC.'s liability is limited to repair or replacement of products found to be defective, and specifically excludes liability for incidental or consequential loss or damage.

This product complies with safety specifications and requirements for connecting devices and towing systems of the state of New York, V.E.S.C.Regulation V-5 and SAE J684.