

YEARS: 2018-PRESENT

MAKE: CHEVROLET / BUICK

MODEL: TRAVERSE / ENCLAVE

STYLE: SUV

WARNING: NEVER EXCEED YOUR VEHICLE MANUFACTURER'S RECOMMENDED TOWING CAPACITY
 For more information log onto www.curtmfg.com & for helpful towing tips log onto www.hitchinfo.com

WEIGHT CARRYING:
 TRAILER WEIGHT: 5,000 LBS.
 TONGUE WEIGHT: 750 LBS.

WEIGHT DISTRIBUTION:
 TRAILER WEIGHT: 5,000 LBS.
 TONGUE WEIGHT: 750 LBS.

PRO INSTALL TIME: 40 MIN.
NOVICE INSTALL TIME: 80 MIN.

IF YOU ARE HESITANT TO UNDERTAKE THIS TASK ON YOUR OWN, CONTACT AN AUTHORIZED CURT INSTALLER FOR ADDITIONAL ASSISTANCE.

INSTALLATION REQUIRES:

| | | |
|---------------|----------------|------------------|
| RATCHET | SOCKETS | SOCKET EXTENSION |
| TORQUE WRENCH | SAFETY GLASSES | SCREW DRIVER |
| TORX BIT | | |
| | | |

INSTALLATION TIPS:

- BEFORE YOU BEGIN INSTALLATION, READ ALL INSTRUCTIONS THOROUGHLY.
- TO EASE INSTALLATION, 2 PEOPLE MAY BE REQUIRED.
- USING PROPER TOOLS WILL GREATLY IMPROVE THE QUALITY OF THE INSTALL AND REDUCE THE TIME REQUIRED.
- NEED HELP OR HAVE SOME QUESTIONS? CALL TECHNICAL SUPPORT AT 800.798.0813

LEVEL OF DIFFICULTY: MODERATE

| EASY | MODERATE | CHALLENGING |
|------|------------------------|-------------|
| | LOWER EXHAUST | |
| | NO DRILLING REQUIRED | |
| | FISHWIRE (4) FASTENERS | |
| | REAR PART REMOVAL | |
| | | |

VEHICLE PHOTO:



REPRESENTATIVE PHOTO

HITCH ILLUSTRATION:

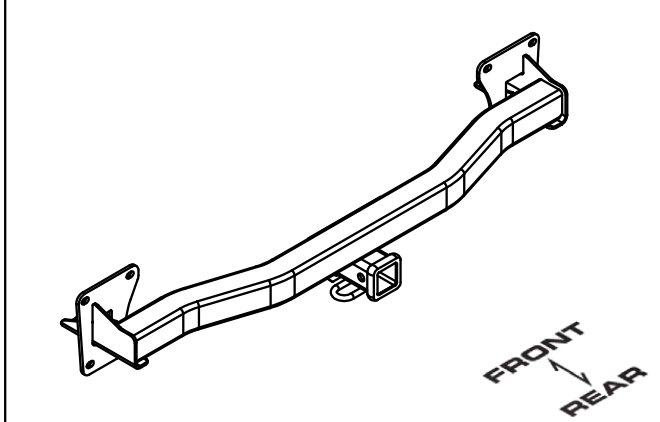

MAKE SURE YOUR HITCH MATCHES

PERIODICALLY CHECK THIS RECEIVER HITCH TO ENSURE ALL FASTENERS ARE TIGHT AND ALL STRUCTURAL COMPONENTS ARE SOUND

CURT Manufacturing LLC. warrants this product to be free of defects in material and/or workmanship at the time of retail purchase by the original purchaser. If the product is found to be defective, CURT Manufacturing LLC. may repair or replace the product at their option, when the product is returned, prepaid, with proof of purchase. Alteration to, misuse of, or improper installation of this product voids the warranty. CURT Manufacturing LLC.'s liability is limited to repair or replacement of products found to be defective, and specifically excludes liability for incidental or consequential loss or damage.

For more information log onto www.curtmfg.com

This product complies with safety specifications and requirements for connecting devices and towing systems of the state of New York, V.E.S.C.Regulation V-5 and SAE J684.



SCAN FOR MORE INFO

INSTALLATION WALKTHROUGH:

| Parts List | | | |
|------------|-----|--------------|--|
| ITEM | QTY | PART NUMBER | DESCRIPTION |
| 1 | 4 | 10-10287 | BOLT, CAR,1/2-13 UNC,1-1/2,GRD8,YZ |
| 2 | 4 | CM-SP12 | .250 x 1.00 x 2.00" SQUARE HOLE SPACER |
| 3 | 4 | 30-00149 | WASHER, S-CON,1/2,YZ |
| 4 | 4 | 20-00037 | NUT, HEX,1/2-13 UNC,GRD8 |
| 5 | 4 | 10-10338 | HHCS,M10x1.5,45,CL10.9,CZ |
| 6 | 4 | 30-00148 | WASHER, S-CON,3/8,YZ |
| 7 | 4 | 1_2 FISHWIRE | 1/2" FISHWIRE |

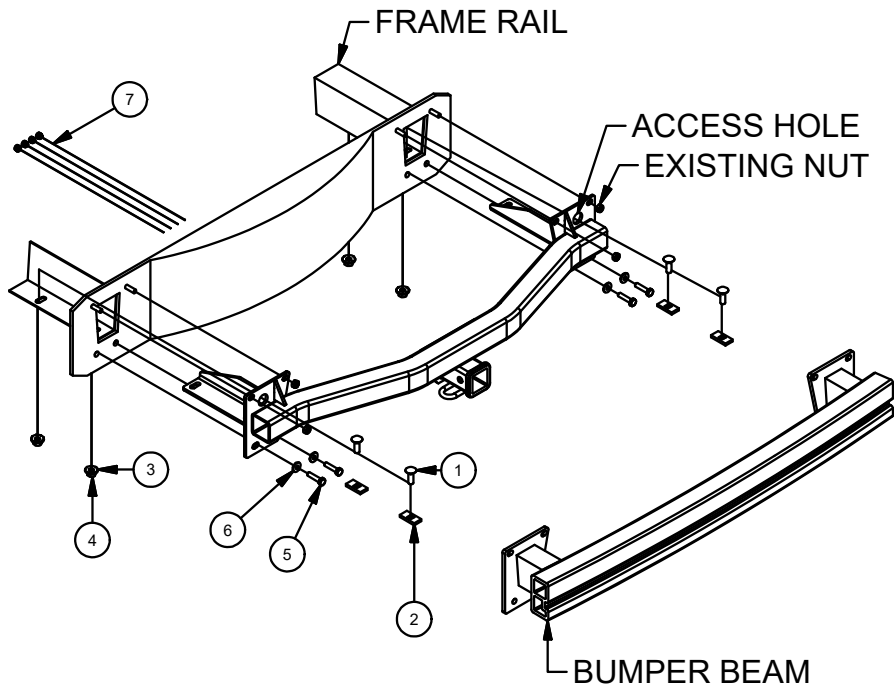

FISHWIRE TECHNIQUE

INSERT COILED END OF FISHWIRE TOOL THROUGH HITCH MOUNTING HOLE IN VEHICLE FRAME RAIL AND OUT THE ACCESS HOLE. PASS COILED END OF FISHWIRE THROUGH SPACER AND THREAD BOLT INTO COIL. KINK WIRE TO KEEP SPACER SEPARATE FROM BOLT AS SHOWN. PULL FISHWIRE, SPACER, AND BOLT THROUGH FRAME AND OUT MOUNTING HOLE. USE FISHWIRE TO GUIDE HITCH DURING MOUNTING AND PREVENT LOSS OF BOLT / SPACER INSIDE FRAME RAIL.

NOTE: SOME VEHICLES MAY FISHWIRE THROUGH END OF FRAME

FRONT
↓
REAR

1. Open the tailgate. Pry open (4) plastic covers below tail lights and remove the (4) screws using a 7mm socket, (2) each side. Remove (2) screws connecting the bottom edge of the fascia to metal support tabs using a T20 socket. Remove (8) screws that connect the wheel well liner to the fascia using T15 socket, (4) each side. Gently pull back the wheel well trim, remove (2) screws that connect the fascia to the vehicle body with a 7mm socket, (1) each side. Starting from the wheel well gently pull off fascia. Unplug any wires that are attached.

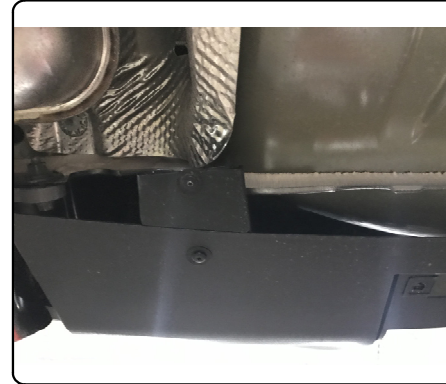

2. Remove (4) M10 nuts with a 15mm socket from the top bumper attachments, set nuts aside for re-attachment, (2) each side. Remove (4) M10 bolts with a 15mm socket from the bottom bumper attachments, (2) each side. Return the bumper beam and bolts to the vehicle owner.

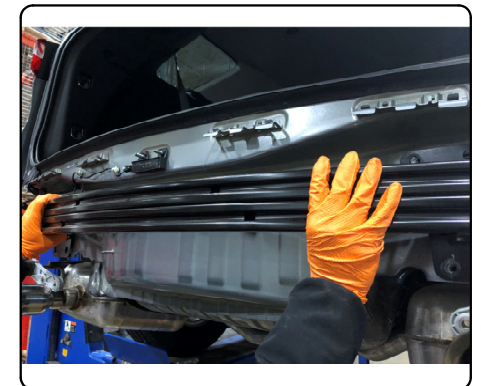

INSTALLATION WALKTHROUGH:

3. Raise the hitch into position over the bumper studs, install the nuts removed earlier. Raise exhaust hangers into position, install the M10 bolts and conical washers (teeth side towards hitch). Fishwire the carriage bolts and spacers into the vehicle frame through the access hole in the hitch, install the conical washer (teeth side toward hitch) and nuts.

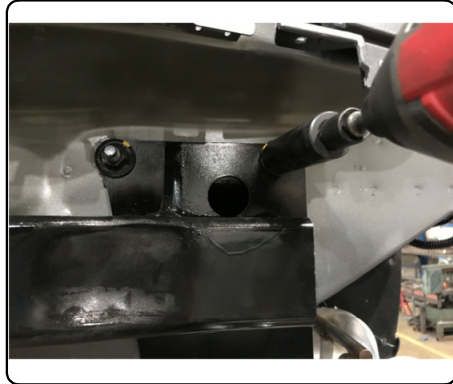

4. Tighten all 1/2" fasteners with torque wrench to 110lb-ft and all M10 fasteners to 45lb-ft.



For more information log onto www.curtmfg.com

5. Reverse the process used in step 1 to re-install the fascia. Be sure to reconnect any plugs that were disconnected. *Vehicle fascia has a removeable panel for hitch usage. Panel may be replaced when hitch is not in use.

INSTALLATION COMPLETE



TOWING SAFETY INFORMATION

Gross Trailer Weight / GTW

The Gross Trailer Weight is the weight of the trailer & cargo. Measure this by putting the fully loaded trailer on a vehicle scale.

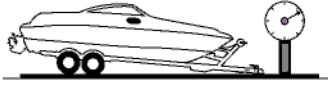

Tongue Weight / TW

The downward force that is exerted on the hitch ball by the coupler. The tongue weight will vary depending on where the load is positioned in relationship to the trailer axle(s). To measure the tongue weight, use either a commercial scale or a bathroom scale with the coupler at towing height. When using a bathroom scale with heavier tongue weights, use the method shown and multiply the scale reading by 3.

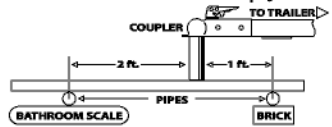

Weight Carrying / WC

The total weight of both the trailer and the cargo inside. Never exceed the weight capacity of your trailer hitch.

Weight Distribution / WD

Used to balance the weight of the cargo between the front and rear wheels throughout the trailer, allowing for better steering, braking, and level riding.



Sway Control

A device used to reduce the lateral movements of the trailer that are caused by the wind. This works in conjunction with a weight distribution hitch. Do not use this on a class 1 or 2 hitch, or with surge brakes.

How Much Can You Safely Tow?

| TONGUE WEIGHT (lb) | 1000 | 2000 | 3000 | 4000 | 5000 | 6000 | 7000 | 8000 | 10,000 | 12,000 |
|---|------|------|------|------|------|------|------|------|--------|--------|
| Tongue weight should be about 10 to 15 percent of the gross trailer weight. | | | | | | | | | | |
| CLASS 1 | | | | | | | | | | |
| CLASS 2 | | | | | | | | | | |
| CLASS 3 | | | | | | | | | | |
| CLASS 4 | | | | | | | | | | |
| CLASS 5 | | | | | | | | | | |
| TRAILER TYPE | | | | | | | | | | |
| Camper | 11' | 12' | 13' | 14' | 15' | 16' | | | | |
| lbs. | 1100 | 1200 | 1300 | 1400 | 1500 | 1600 | | | | |
| Vacation | 18' | 19' | 20' | 21' | 22' | 24' | 26' | 28' | 30' | 32' |
| lbs. | 2100 | 2400 | 2700 | 3000 | 3300 | 3600 | 3900 | 4200 | 4500 | 4800 |
| Vacation | 18' | 19' | 20' | 21' | 22' | 24' | 26' | 28' | 30' | 32' |
| lbs. | 2800 | 3200 | 3600 | 4000 | 4400 | 4800 | 5200 | 5600 | 6000 | 6400 |
| 5th Wheel | | | | | | | | | | |

Refer to owner's manual for towing capabilities and limitations.

Ball Mount

The ball mount is placed inside the opening of the receiver hitch which is mounted to the vehicle. Make sure a hitch pin and clip is properly securing the ball mount to the receiver hitch before you begin towing.

- A: Rise. B: Drop. C: Hole Size. D: Length.

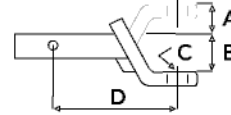

Trailer Ball

The connection from the hitch to the trailer. There are many factors that determine the correct hitch ball:

- Number one is the hitch ball's gross trailer weight rating.
- The mounting platform must be at least 3/8" thick.
- The hole diameter must not be more than 1/16" larger than the threaded shank.
- Every time you tow, check the nut and lock washer to make sure they are fastened securely.
- A: Ball Dia. B: Shank Length. C: Shank Dia. D: Shank Rise.

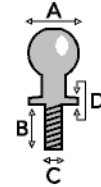

Coupler

The component that is placed over the trailer ball to connect the vehicle to the trailer. Be sure that the coupler size matches the size of the hitch ball and that the coupler handle is securely fastened. To determine what size hitch ball you need for your application you will need to know the size of coupler that is on the trailer. Be sure your coupler is properly adjusted to the ball you are using.

NOTE: For added security the use of safety devices such as Coupler Safety Pins and Locks is strongly recommended.

Safety Chains

Safety chains are a requirement and should be crossed under the tongue of the trailer so that the tongue will not drop to the road if it becomes separated from the hitch. Always leave enough slack so you can turn. Never allow the safety chains to drag on the ground and never attach the chains to the bumper.

Trailer Classification: Safety Chain Breaking Force - Minimum

Class 1: 2,000 lbs. (8.9 kN)

Class 2: 3,500 lbs. (15.6 kN)

Class 3: 5,000 lbs. (22.2 kN)

The strength rating of each length of safety chain or its equivalent and its attachments shall be equal to or exceed in minimum breaking force the GVWR (Gross Vehicle Weight Rating) of the trailer.

Electrical

Trailer lights, Electric Brakes, Break-away systems - Every time you tow, be sure to check that all components are working properly.

Wiring identification by color:

| | | | | | | |
|--------------------|-------------------|------------|--------|-----------------|-----------------|----------------|
| 7-WAY | | | | | | |
| 6-WAY | | | | | | |
| 5-WAY | | | | | | |
| 4-WAY | | | | | | |
| GREEN | YELLOW | BROWN | WHITE | RED | BLUE | PURPLE |
| RIGHT TURN & BRAKE | LEFT TURN & BRAKE | TAILLIGHTS | GROUND | AUXILIARY POWER | ELECTRIC BRAKES | BACK-UP LIGHTS |

CURT DISCLAIMER: WIRING COLOR SHOWN WORK IN CONJUNCTION WITH CURT MANUFACTURING PRODUCTS.

13433

CHEVROLET TRAVERSE / BUICK ENCLAVE

12/16/2019

GROSS LOAD CAPACITY WHEN USED AS A WEIGHT CARRYING HITCH: 5,000 LBS. TRAILER WEIGHT & 750 LBS. TONGUE WEIGHT.

GROSS LOAD CAPACITY WHEN USED AS A WEIGHT DISTRIBUTION HITCH: 5,000 LBS. TRAILER WEIGHT & 750 LBS. TONGUE WEIGHT

**WARNING: *** DO NOT EXCEED VEHICLE MANUFACTURER'S RECOMMENDED TOWING CAPACITY. *****FOR MORE INFORMATION LOG ONTO WWW.CURTMFG.COM
HAVING INSTALLATION QUESTIONS? CALL TECHNICAL SUPPORT AT 1-800-798-0813

| Parts List | | | |
|------------|-----|--------------|--|
| ITEM | QTY | PART NUMBER | DESCRIPTION |
| 1 | 4 | CM-SP12 | .250 x 1.00 x 2.00" SQUARE HOLE SPACER |
| 2 | 4 | 20-00037 | NUT, HEX, 1/2-13 UNC, GRD8 |
| 3 | 4 | 30-00148 | WASHER, S-CON, 3/8, YZ |
| 4 | 4 | 1_2 FISHWIRE | 1/2" FISHWIRE |
| 5 | 1 | POLY BAG | CLEAR POLY BAG |
| 6 | 4 | 30-00149 | WASHER, S-CON, 1/2, YZ |
| 7 | 4 | 10-10338 | HHCS, M10x1.5, 45, CL10.9, CZ |

TOOLS REQUIRED

RATCHET
T15, T20 TORX
7mm, 15mm, 3/4" SOCKET
6" SOCKET EXTENSION
TORQUE WRENCH
SAFETY GLASSES
SCREW DRIVER

FISHWIRE TECHNIQUE

INSERT COILED END OF FISHWIRE TOOL THROUGH HITCH MOUNTING HOLE IN VEHICLE FRAME RAIL AND OUT THE ACCESS HOLE. PASS COILED END OF FISHWIRE THROUGH SPACER AND THREAD BOLT INTO COIL. KINK WIRE TO KEEP SPACER SEPARATE FROM BOLT AS SHOWN. PULL FISHWIRE, SPACER, AND BOLT THROUGH FRAME AND OUT MOUNTING HOLE. USE FISHWIRE TO GUIDE HITCH DURING MOUNTING AND PREVENT LOSS OF BOLT / SPACER INSIDE FRAME RAIL.

*NOTE: SOME VEHICLES MAY FISHWIRE THROUGH END OF FRAME**

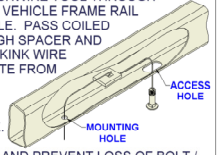

CONICAL TOOTHED WASHER ORIENTATION DIAGRAM

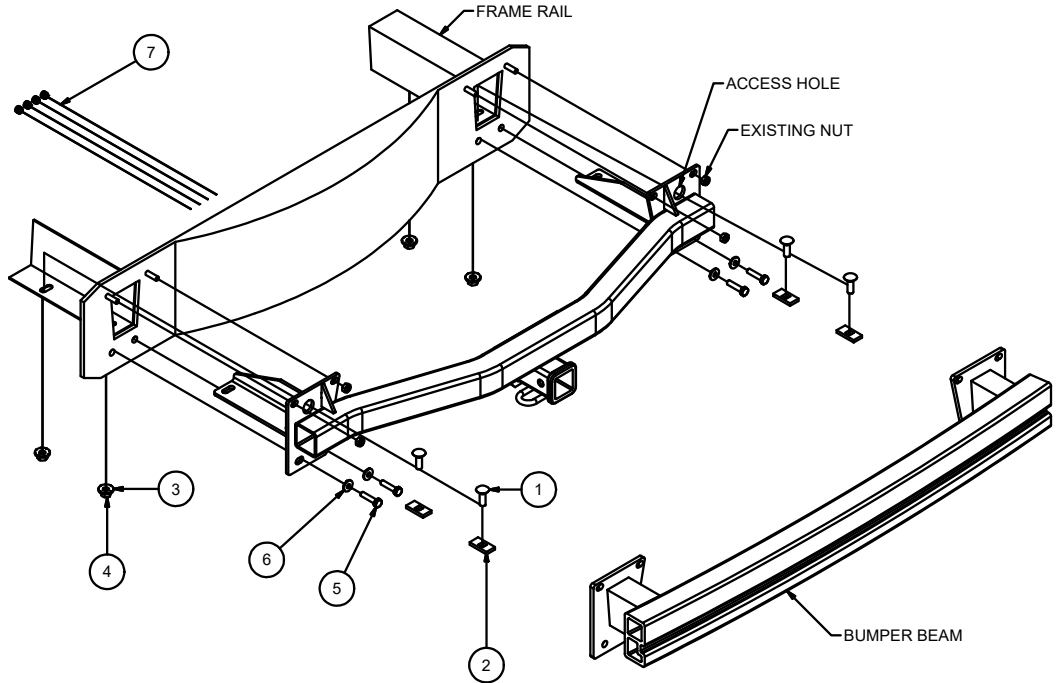
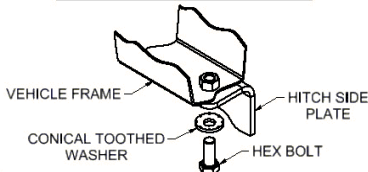

HITCH WEIGHT: 40 LBS.

INSTALL TIME

PROFESSIONAL: 40 MINUTES

NOVICE (DIY): 80 MINUTES

INSTALL NOTES:

- LOWER EXHAUST
- REMOVE/REINSTALL PARTS
- NO DRILLING REQUIRED
- FISHWIRING REQUIRED

INSTALLATION STEPS

1. Open the tailgate. Pry open (4) plastic covers below tail lights to remove the (4) screws using a 7mm socket, (2) each side. Remove (2) screws that connect the bottom lower edge of the fascia to the metal support tabs using a T20 socket. Remove (8) screws that connect the wheel well liner to the fascia using T15 socket, (4) each side. Gently pull back the wheel well trim, remove (2) screws that connect the fascia to the vehicle body with a 7mm socket, (1) each side. Starting from the wheel well gently pull off fascia. Unplug any wires that are attached.
2. Remove (4) M10 nuts with a 15mm socket from the top bumper attachments, set nuts aside for re-attachment, (2) each side. Remove (4) M10 bolts with a 15mm socket from the bottom bumper attachments, (2) each side. Be sure to support the vehicle exhaust system as these bolts also attach the exhaust hangers. Return the bumper beam and bolts to the vehicle owner.
3. Raise the hitch into position over the bumper studs, install the nuts removed earlier. Raise exhaust hangers into position, install the M10 bolts and conical washers (teeth side towards hitch). Fishwire the carriage bolts and spacers into the vehicle frame through the access hole in the hitch, install the conical washer (teeth side toward hitch) and nuts.
4. Tighten all 1/2" fasteners with torque wrench to 110lb-ft and all M10 fasteners to 45lb-ft.
5. Reverse the process used in step 1 to re-install the fascia. Be sure to reconnect any plugs that were disconnected. *Vehicle fascia has a removeable panel for hitch usage. Panel may be replaced when hitch is not in use.

PERIODICALLY CHECK THIS RECEIVER HITCH TO ENSURE THAT ALL FASTENERS ARE TIGHT AND THAT ALL STRUCTURAL COMPONENTS ARE SOUND.



Scan for more information

CURT Manufacturing LLC, warrants this product to be free of defects in material and/or workmanship at the time of retail purchase by the original purchaser. If the product is found to be defective, CURT Manufacturing LLC, may repair or replace the product, at their option, when the product is returned, prepaid, with proof of purchase. Alteration to, misuse of, or improper installation of this product voids the warranty. CURT Manufacturing LLC's liability is limited to repair or replacement of products found to be defective, and specifically excludes liability for incidental or consequential loss or damage.

This product complies with safety specifications and requirements for connecting devices and towing systems of the state of New York, V.E.S.C.Regulation V-5 and SAE J684.