

YEARS: 2020-PRESENT

MAKE: FORD

MODEL: EXPLORER

STYLE: SUV

**WARNING: NEVER EXCEED YOUR VEHICLE MANUFACTURER'S RECOMMENDED TOWING CAPACITY**  
 For more information log onto [www.curtmfg.com](http://www.curtmfg.com) & for helpful towing tips log onto [www.hitchinfo.com](http://www.hitchinfo.com)

**WEIGHT CARRYING:**  
 TRAILER WEIGHT: 6,000 LBS.  
 TONGUE WEIGHT: 600 LBS.

**PRO INSTALL TIME: 60 MIN.**  
**NOVICE INSTALL TIME: 120 MIN.**

IF YOU ARE HESITANT TO UNDERTAKE THIS TASK ON YOUR OWN, CONTACT AN AUTHORIZED CURT INSTALLER FOR ADDITIONAL ASSISTANCE.

**INSTALLATION REQUIRES:**

RATCHET	TORQUE WRENCH	6" SOCKET EXTENSION
7mm 10mm 21mm SOCKET	AVIATION SHEARS	PLASTIC RIVET GUN
MARKER	TAPE MEASURE	SAFETY GLASSES
POWER DRILL	DRILL BIT 1/4"	

**INSTALLATION TIPS:**

- BEFORE YOU BEGIN INSTALLATION, READ ALL INSTRUCTIONS THOROUGHLY.
- TO EASE INSTALLATION, 2 PEOPLE MAY BE REQUIRED.
- USING PROPER TOOLS WILL GREATLY IMPROVE THE QUALITY OF THE INSTALL AND REDUCE THE TIME REQUIRED.
- NEED HELP OR HAVE SOME QUESTIONS? CALL TECHNICAL SUPPORT AT 877.287.8634

**LEVEL OF DIFFICULTY: MODERATE**

<b>EASY</b>	<b>MODERATE</b>	<b>CHALLENGING</b>
	NO FRAME DRILLING	
	FISHWIRE HARDWARE	

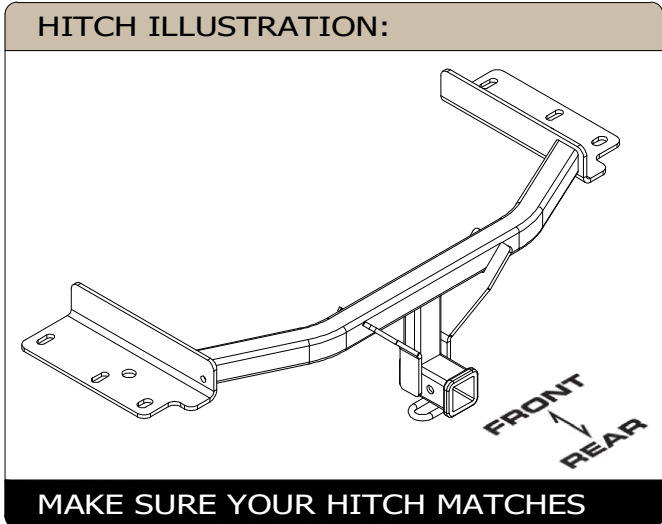

**PERIODICALLY CHECK THIS RECEIVER HITCH TO ENSURE ALL FASTENERS ARE TIGHT AND ALL STRUCTURAL COMPONENTS ARE SOUND**  
 CURT Manufacturing LLC. warrants this product to be free of defects in material and/or workmanship at the time of retail purchase by the original purchaser. If the product is found to be defective, CURT Manufacturing LLC. may repair or replace the product at their option, when the product is returned, prepaid, with proof of purchase. Alteration to, misuse of, or improper installation of this product voids the warranty. CURT Manufacturing LLC.'s liability is limited to repair or replacement of products found to be defective, and specifically excludes liability for incidental or consequential loss or damage.  
 For more information log onto [www.curtmfg.com](http://www.curtmfg.com)  
 This product complies with safety specifications and requirements for connecting devices and towing systems of the state of New York, V.E.S.C.Regulation V-5 and SAE J684.

## INSTALLATION WALKTHROUGH:

Parts List			
ITEM	QTY	PART NUMBER	DESCRIPTION
1	4	10-10278	BOLT, CAR, 1/2-13 UNC, 1-1/4, GRD8, YZ
2	4	20-00062	NUT, SER-FLANGE, 1/2-13 UNC, GRD8, YZ
3	4	CM-SP6	.250 x 1.00 x 3.00" SQUARE HOLE SPACER
4	4	1_2 FISHWIRE	1/2" FISHWIRE
5	2	10-10122	HHCS, M16X2,35, CL10.9
6	2	30-00087	WASHER, FLAT, M16
7	4	M6 RIVET	NYLON RIVET

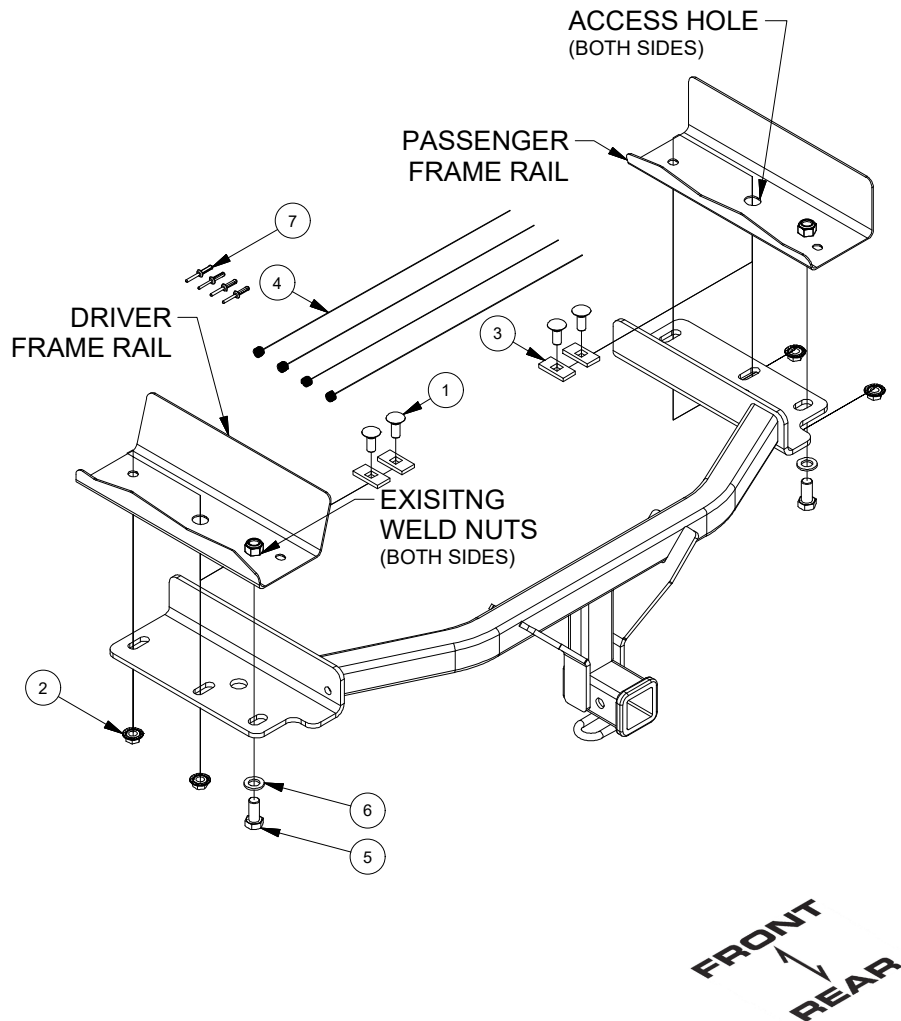

1. If present remove underbody panel by removing (8) fasteners using 10mm socket and (4) plastic fasteners. Set aside panel for reinstallation.

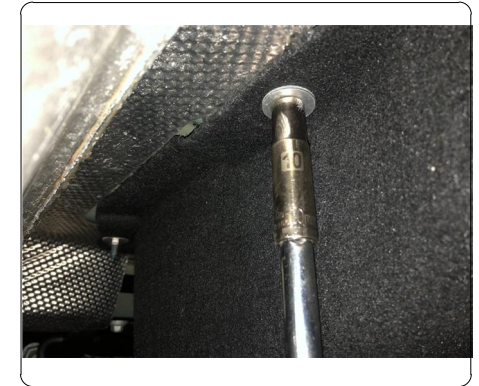
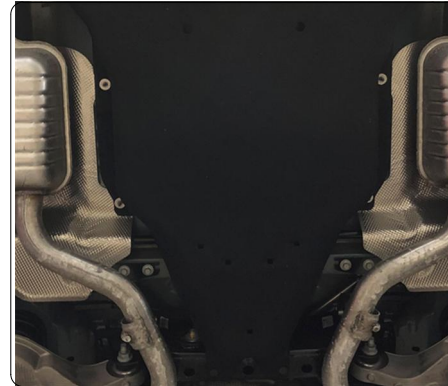

2. Lower exhaust by removing (1) fastener on outside of frame rail, on each side, using 10mm socket. Remove (2) exhaust isolator hangers by using Rubber Isolator Removal Diagram as reference.  
**NOTE:** Support exhaust to avoid damage.

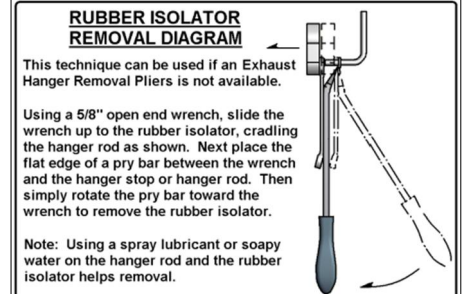
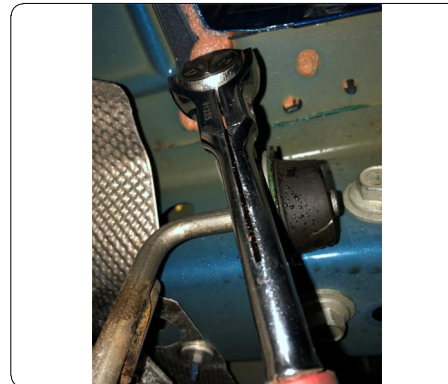

## INSTALLATION WALKTHROUGH:

3. Remove heat shield by removing (5) fasteners, on each side, using 10mm socket. Remove (2) wheel well fasteners, on each side using 7mm socket. Trim using trim diagram as reference.

**NOTE:** All dimensions are approximate, confirm fit prior to trim.

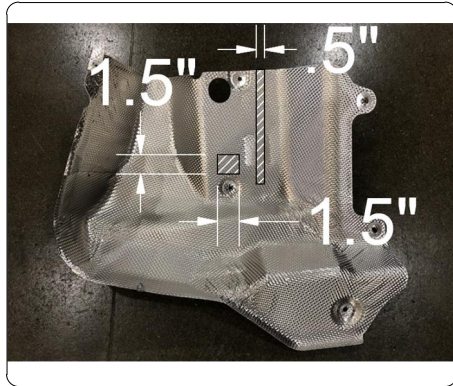

4. Remove M16 bumper bolt in frame, on each side, using 21mm socket. Return to owner.

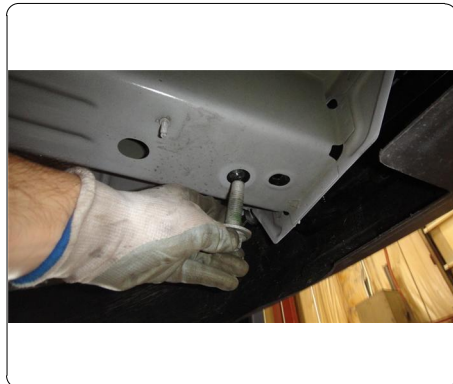

For more information log onto [www.curtmfg.com](http://www.curtmfg.com)

5. If kick sensor is present, remove (4) rivets along rear fascia, starting from driver side, to avoid damaging kick sensor while trimming. Replacement rivets are included.

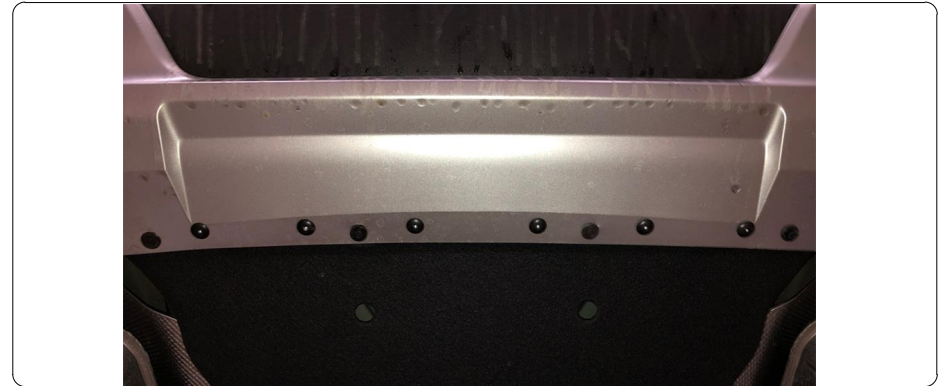

6. Remove (2) fasteners located inside bumper cover to allow rear fascia to flex. Trim fascia using aviation shears as shown in trim diagram. Avoid sensor and wires by disconnecting from fascia.
- NOTE:** All dimensions are approximate, confirm fit prior to trim.

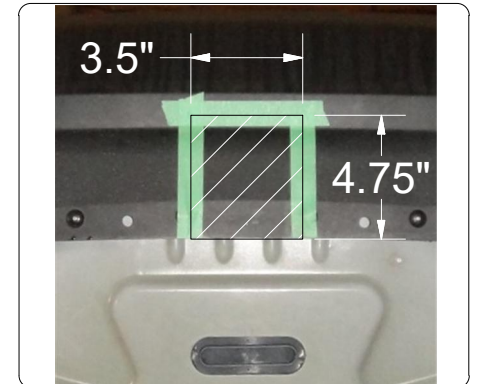

## INSTALLATION WALKTHROUGH:

7. Fishwire (2) 1/2" carriage bolts and (2) CM-SP6 spacers into access hole and out mounting holes on each side. Reinstall trimmed heat shield.  
**NOTE:** Do not reinstall rearward most frame rail nut.

### FISHWIRE TECHNIQUE

INSERT COILED END OF FISHWIRE TOOL THROUGH HITCH MOUNTING HOLE IN VEHICLE FRAME RAIL AND OUT THE ACCESS HOLE. PASS COILED END OF FISHWIRE THROUGH SPACER AND THREAD BOLT INTO COIL. KINK WIRE TO KEEP SPACER SEPERATE FROM BOLT AS SHOWN. PULL FISHWIRE, SPACER, AND BOLT THROUGH FRAME AND OUT MOUNTING HOLE. USE FISHWIRE TO GUIDE HITCH DURING MOUNTING AND PREVENT LOSS OF BOLT / SPACER INSIDE FRAME RAIL.

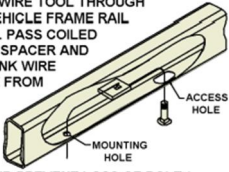

\*\*NOTE: SOME VEHICLES MAY FISHWIRE THROUGH END OF FRAME\*\*



8. Raise hitch into position. Torque 1/2" hardware to 75 ft-lbs and torque M16 hardware to 146 ft-lbs.

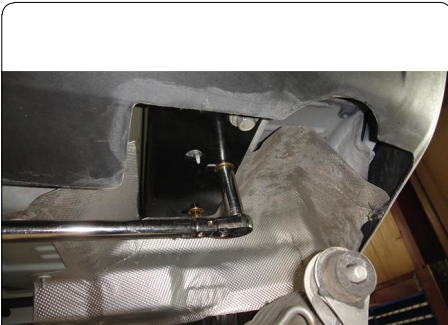

9. Reinstall vehicle components using steps 1-5 in reverse order.



## TOWING SAFETY INFORMATION

### Gross Trailer Weight / GTW

The Gross Trailer Weight is the weight of the trailer & cargo. Measure this by putting the fully loaded trailer on a vehicle scale.

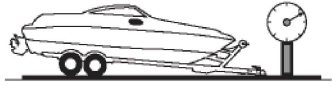

### Tongue Weight / TW

The downward force that is exerted on the hitch ball by the coupler. The tongue weight will vary depending on where the load is positioned in relationship to the trailer axle(s). To measure the tongue weight, use either a commercial scale or a bathroom scale with the coupler at towing height. When using a bathroom scale with heavier tongue weights, use the method shown and multiply the scale reading by 3.

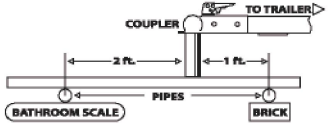

### Weight Carrying / WC

The total weight of both the trailer and the cargo inside. Never exceed the weight capacity of your trailer hitch.

### Weight Distribution / WD

Used to balance the weight of the cargo between the front and rear wheels throughout the trailer, allowing for better steering, braking, and level riding.



### Sway Control

A device used to reduce the lateral movements of the trailer that are caused by the wind. This works in conjunction with a weight distribution hitch. Do not use this on a class 1 or 2 hitch, or with surge brakes.

### How Much Can You Safely Tow?

TONGUE WEIGHT lbs	1000	2000	3000	4000	5000	6000	7000	8000	10,000	12,000
Tongue weight should be about 10 to 15 percent of the gross trailer weight.										
CLASS 1										
CLASS 2										
CLASS 3										
CLASS 4										
CLASS 5										
<b>Camper</b>	11'	12'	13'	14'	15'	16'				
lbs	1100	1200	1300	1400	1500	1600				
<b>Vacation</b>	14'	16'	18'	20'	22'	24'	26'	28'	30'	32'
lbs	2100	2400	2700	3000	3300	3600	3900	4200	4500	4800
<b>Vacation</b>	14'	16'	18'	20'	22'	24'	26'	28'	30'	32'
lbs	2800	3200	3600	4000	4400	4800	5200	5600	6000	6400
<b>5th Wheel</b>										

Refer to owner's manual for towing capabilities and limitations.

### Ball Mount

The ball mount is placed inside the opening of the receiver hitch which is mounted to the vehicle. Make sure a hitch pin and clip is properly securing the ball mount to the receiver hitch before you begin towing.

- A: Rise. B: Drop. C: Hole Size. D: Length.

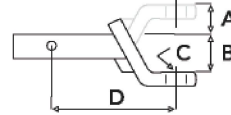

### Trailer Ball

The connection from the hitch to the trailer. There are many factors that determine the correct hitch ball:

- Number one is the hitch ball's gross trailer weight rating.
- The mounting platform must be at least 3/8" thick.
- The hole diameter must not be more than 1/16" larger than the threaded shank.
- Every time you tow, check the nut and lock washer to make sure they are fastened securely.
- A: Ball Dia. B: Shank Dia. C: Shank Length. D: Shank Rise.

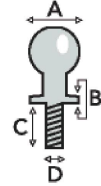

### Coupler

The component that is placed over the trailer ball to connect the vehicle to the trailer. Be sure that the coupler size matches the size of the hitch ball and that the coupler handle is securely fastened. To determine what size hitch ball you need for your application you will need to know the size of coupler that is on the trailer. Be sure your coupler is properly adjusted to the ball you are using.

NOTE: For added security the use of safety devices such as Coupler Safety Pins and Locks is strongly recommended.

### Safety Chains

Safety chains are a requirement and should be crossed under the tongue of the trailer so that the tongue will not drop to the road if it becomes separated from the hitch. Always leave enough slack so you can turn. Never allow the safety chains to drag on the ground and never attach the chains to the bumper.

Trailer Classification: Safety Chain Breaking Force - Minimum

- Class 1: 2,000 lbs. (8.9 kN)
- Class 2: 3,500 lbs. (15.6 kN)
- Class 3: 5,000 lbs. (22.2 kN)

The strength rating of each length of safety chain or its equivalent and its attachments shall be equal to or exceed in minimum breaking force the GVWR (Gross Vehicle Weight Rating) of the trailer.

### Electrical

Trailer lights, Electric Brakes, Break-away systems - Every time you tow, be sure to check that all components are working properly.

Wiring identification by color:



13438

FORD EXPLORER

2/11/2020

GROSS LOAD CAPACITY WHEN USED AS A WEIGHT CARRYING HITCH: 6,000 LBS. TRAILER WEIGHT & 600 LBS. TONGUE WEIGHT.

WARNING: ALL NON-TRAILER LOADS APPLIED TO THIS PRODUCT MUST BE SUPPORTED BY 18050 STABILIZING STRAPS.



**WARNING: \*\* FAILURE TO PROPERLY SUPPORT NON-TRAILER LOADS WILL VOID PRODUCT WARRANTY \*\***

**WARNING: \*\*\* DO NOT EXCEED VEHICLE MANUFACTURER'S RECOMMENDED TOWING CAPACITY \*\*\***

FOR MORE INFORMATION LOG ONTO WWW.CURTMFG.COM & FOR HELPFUL TOWING TIPS LOG ONTO WWW.HITCHINFO.COM  
HAVING INSTALLATION QUESTIONS? CALL TECHNICAL SUPPORT AT 1-800-798-0813



Parts List			
ITEM	QTY	PART NUMBER	DESCRIPTION
1	4	10-10278	BOLT, CAR, 1/2-13 UNC, 1-1/4, GRD8, YZ
2	4	20-00062	NUT, SER-FLANGE, 1/2-13 UNC, GRD8, YZ
3	4	CM-SP6	.250 x 1.00 x 3.00" SQUARE HOLE SPACER
4	4	1_2 FISHWIRE	1/2" FISHWIRE
5	2	10-10122	HHCS, M16X2, 35, CL10.9
6	2	30-00087	WASHER, FLAT, M16
7	4	M6 RIVET	NYLON RIVET

TOOLS REQUIRED
RATCHET
TORQUE WRENCH
6" SOCKET EXTENSION
7mm / 10mm / 21mm SOCKETS
AVIATION SHEARS
POWER DRILL
MARKER
TAPE MEASURE
SAFETY GLASSES
PLASTIC RIVET GUN
1/4" DRILL BIT

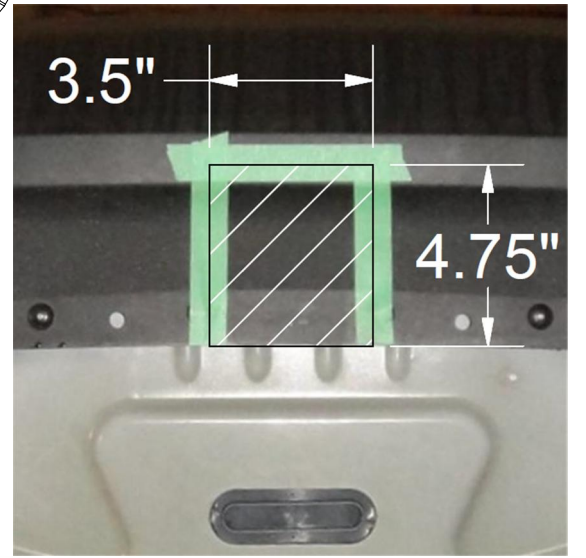
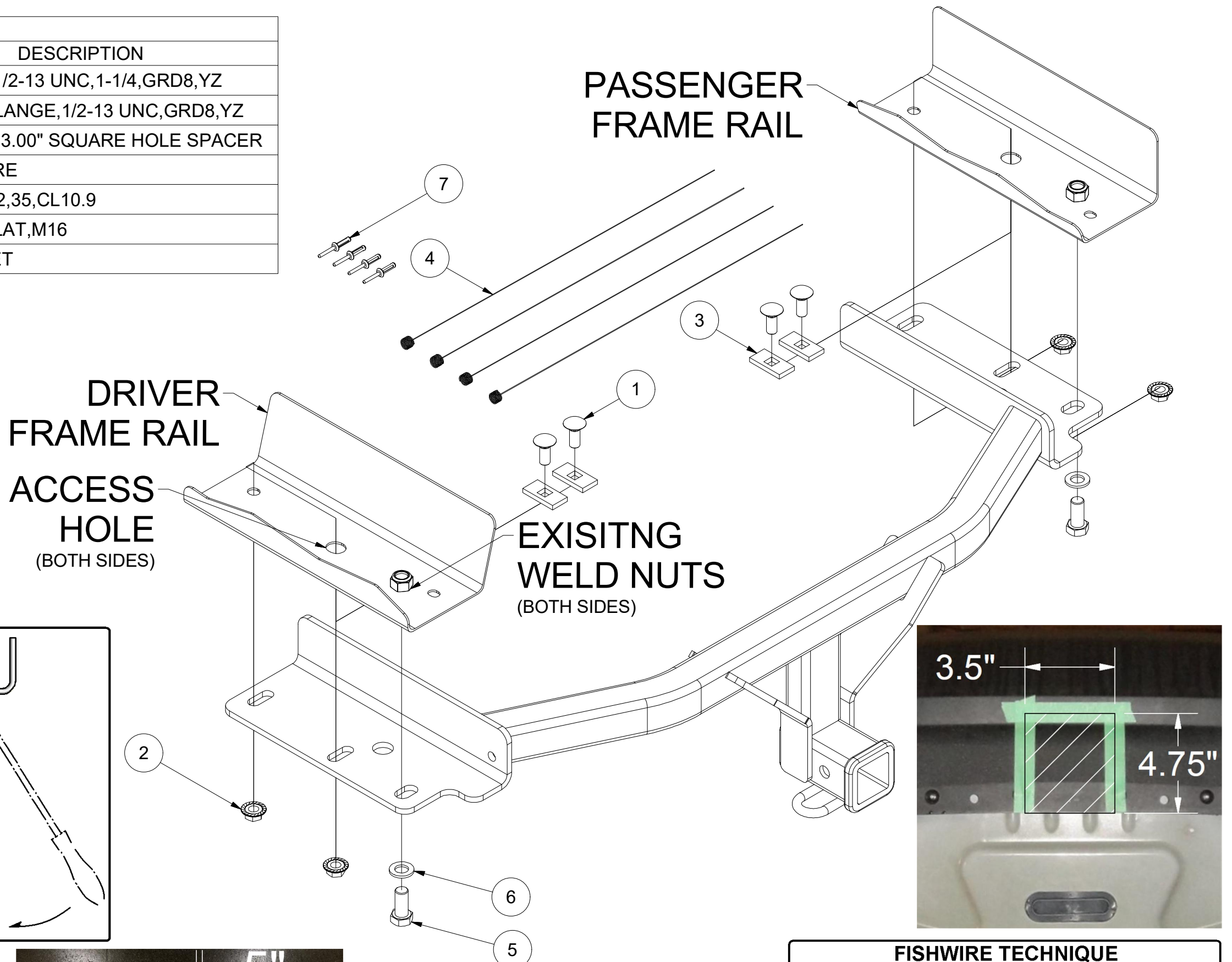

**RUBBER ISOLATOR REMOVAL DIAGRAM**

This technique can be used if an Exhaust Hanger Removal Pliers is not available.

Using a 5/8" open end wrench, slide the wrench up to the rubber isolator, cradling the hanger rod as shown. Next place the flat edge of a pry bar between the wrench and the hanger stop or hanger rod. Then simply rotate the pry bar toward the wrench to remove the rubber isolator.

Note: Using a spray lubricant or soapy water on the hanger rod and the rubber isolator helps removal.

**FISHWIRE TECHNIQUE**

INSERT COILED END OF FISHWIRE TOOL THROUGH HITCH MOUNTING HOLE IN VEHICLE FRAME RAIL AND OUT THE ACCESS HOLE. PASS COILED END OF FISHWIRE THROUGH SPACER AND THREAD BOLT INTO COIL. KINK WIRE TO KEEP SPACER SEPARATE FROM BOLT AS SHOWN. PULL FISHWIRE, SPACER, AND BOLT THROUGH FRAME AND OUT MOUNTING HOLE. USE FISHWIRE TO GUIDE HITCH DURING MOUNTING AND PREVENT LOSS OF BOLT / SPACER INSIDE FRAME RAIL.

\*\*NOTE: SOME VEHICLES MAY FISHWIRE THROUGH END OF FRAME\*\*

HITCH WEIGHT: 45 LBS.  
INSTALL TIME  
PROFESSIONAL: 60 MINUTES  
NOVICE (DIY): 120 MINUTES  
INSTALL NOTES:  
NO FRAME DRILLING  
FISHWIRE HARDWARE

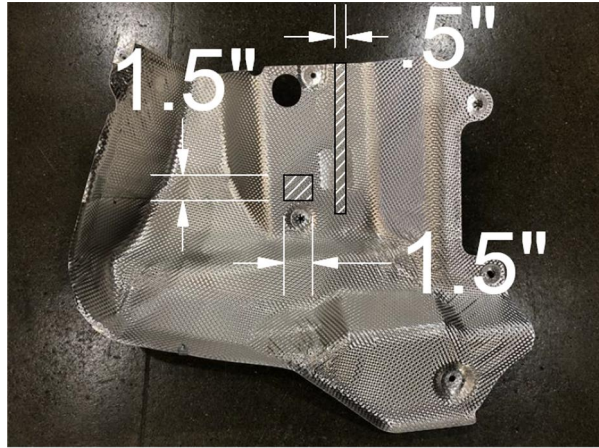

**INSTALLATION STEPS**

1. If present remove underbody panel by removing (8) fasteners using 10mm socket and (4) plastic fasteners. Set aside panel for reinstallation.
2. Lower exhaust by removing (1) fastener on outside of frame rail, on each side, using 10mm socket. Remove (2) exhaust isolator hangers by using Rubber Isolator Removal Diagram as reference.  
**NOTE:** Support exhaust to avoid damage.
3. Remove heat shield by removing (5) fasteners, on each side, using 10mm socket. Remove (2) wheel well fasteners, on each side using 7mm socket. Trim using trim diagram as reference.  
**NOTE:** All dimensions are approximate, confirm fit prior to trim.
4. Remove M16 bumper bolt in frame, on each side, using 21mm socket. Return to owner.
5. If kick sensor is present, remove (4) rivets along rear fascia, starting from driver side, to avoid damaging kick sensor while trimming. Replacement rivets are included.
6. Remove (2) fasteners located inside bumper cover to allow rear fascia to flex. Trim fascia using aviation shears as shown in trim diagram. Avoid sensor and wires by disconnecting from fascia.  
**NOTE:** All dimensions are approximate, confirm fit prior to trim.
7. Fishwire (2) 1/2" carriage bolts and (2) CM-SP6 spacers into access hole and out mounting holes on each side. Reinstall trimmed heat shield.  
**NOTE:** Do not reinstall rearward most frame rail nut.
8. Raise hitch into position. Torque 1/2" hardware to 75 ft-lbs and torque M16 hardware to 146 ft-lbs.
9. Reinstall vehicle components using steps 1-5 in reverse order.

**PERIODICALLY CHECK THIS RECEIVER HITCH TO ENSURE THAT ALL FASTENERS ARE TIGHT AND THAT ALL STRUCTURAL COMPONENTS ARE SOUND.**



Scan for more information

CURT Manufacturing LLC., warrants this product to be free of defects in material and/or workmanship at the time of retail purchase by the original purchaser. If the product is found to be defective, CURT Manufacturing LLC., may repair or replace the product, at their option, when the product is returned, prepaid, with proof of purchase. Alteration to, misuse of, or improper installation of this product voids the warranty. CURT Manufacturing LLC.'s liability is limited to repair or replacement of products found to be defective, and specifically excludes liability for incidental or consequential loss or damage.

This product complies with safety specifications and requirements for connecting devices and towing systems of the state of New York, V.E.S.C.Regulation V-5 and SAE J684.