

INSTALLATION MANUAL

13900

Level of Difficulty

Easy (60 minute install time)

⚠ WARNING

Never exceed the vehicle manufacturer's recommended towing capacity.

Parts List

Qty	Description	#
1	Fishwire, 1/2"	1
2	Hex bolt, 1/2" - 13 x 3 1/2"	2
8	Lock washer, 1/2"	3
8	Hex nut, 1/2" - 13	4
6	Hex bolt, 1/2" - 13 x 1 1/2"	5
6	Flat washer, 1/2"	6

Weight Carrying Capacity

Gross trailer weight (GTW) 5,000 lbs.*

* Chevrolet / GMC Astrovan has a lower weight carrying capacity of 3,500 lbs. GTW

Torque Specifications

1/2" bolt 64 lb-ft.

Use above torque setting unless otherwise noted

Product Photo



Notes

To see our warranty and register your product visit curtmfg.com.

Before you begin installation, read all instructions thoroughly.

Proper tools will improve the quality of installation and reduce the time required.

Hitch weight: 42 pounds. Drilling may be required.

Refer to the table to the left when securing hardware during the installation process to help prevent damage to the product or vehicle.

Do not overload any part of your towing system.

See the vehicle owner's manual to determine the vehicle tow rating.

Product Registration

CURT Group stands behind our products with industry leading warranties. You can help us continue to improve our product line and help us understand your needs by registering your purchase by visiting:

warranty.curtgroup.com/surveys

At CURT Group, customer is king. We value your feedback and we use that information to make improvements on our products. Please, take a minute and let us know how we are doing.

HOLE SELECTION

Frame Size and Hole Selection

Measure center-to-center distance of frame rails. See the tables and figures below and on page 3 to determine which holes to use.

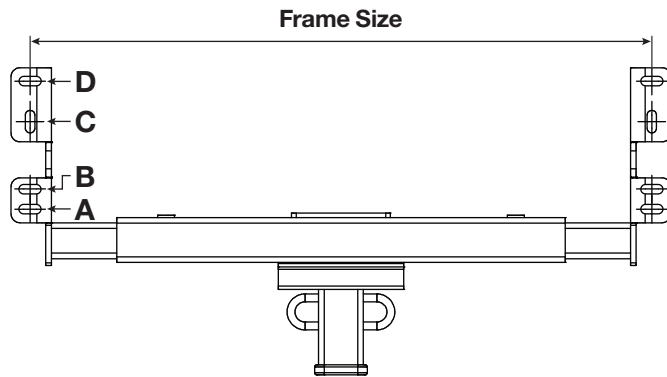

Vehicle Make / Model	Drill Frame Attachment Holes
Chevrolet / GMC	
Astro, extended chassis	Drill hole D Use existing holes B, C
Blazer	Drill hole D Use existing hole A
Blazer, full-size	Drill holes A, C, D
Jimmy, full-size	Drill holes A, C, D
Pickups, full-size, 8' bed, excl. step-side and 1 ton	Drill holes A, C, D
Pickups, full-size, excl. step-side and 1 ton	Drill holes A, C, D
S-10 / S-15 pickup, short bed 4 x 4	Drill hole C Use existing hole B
S-10 / S-15 pickup, long bed	Drill hole D Use existing hole B
S-10 / S-15 pickup, crew cab	Drill hole C Use existing hole B
Safari (spare tire may need relocating)	Drill holes B, C, D
Safari, extended cab	Drill hole D Use existing holes B, C
Silverado / Sierra 1500, classic body, 8' bed	Drill holes C, D Use existing hole A
Silverado / Sierra 2500HD / 3500, full-size, 8' bed, excl. step-side	Drill holes C, D Use existing hole A
Silverado / Sierra 2500LD, 8' bed	Drill holes C, D Use existing hole A
Suburban	Drill holes C, D Use existing hole A
Tahoe	Drill holes A, C, D
G-Series, full-size van	Drill holes A, C, D
Express / Savana, full-size van	Drill holes C, D Use existing hole A
Venture	Drill holes A, C, D
Yukon / Yukon XL	Drill holes A, C, D

Vehicle Make / Model	Drill Frame Attachment Holes
Chrysler	
Town & Country, excl. Stow-n-go	For years 90 - 95 Use existing holes A, D
Town & Country, excl. Stow-n-go	For years 96 -07 Use existing holes A, B, C
Dodge	
Caravan, excl. Stow-n-go	Drill holes A, D
Dakota, including quad cab	Drill holes B, C, D
Pickups, full-size, excl. 1 ton	Drill holes A, C, D
Ramcharger	Drill holes A, B, D
Ford	
Aerostar, extended cab	Drill holes A, B, D
Bronco, full-size	Drill holes A, C, D
Bronco II	Drill holes A, D
Escape	Drill hole D Use existing holes A, B
F-150 pickups, step sides with 6' bed (spare tire may need relocating)	Drill holes A, C, D
F-150 pickups, 8' bed	Drill holes A, C, D
F-250 pickups, 6' bed	Drill holes A, C, D
F-250 / F-350 pickups, 8' bed, excl. 20" spare tire	Drill holes A, C, D
Pickups, 6' and 8' beds, excl. step sides and 1 ton	Use existing holes B, C, D
Ranger, excl. 98 - 06 flare side	Drill holes C, D Use existing hole A
Ranger, 8' bed only (spare tire needs relocating)	Drill holes C, D Use existing hole A
E-series vans, excl. 1 ton	Drill holes C, D Use existing holes A or B
Windstar	Use existing holes B, C
Isuzu	
Hombre, short bed 4 x 4	Drill hole C Use existing hole B
Jeep	
Cherokee XJ	Use existing holes A, B, D
Grand Cherokee	Use existing holes A, B, C
Liberty	Use existing holes A, C
Mazda	
Pickup, excl. 98 - 06 flare side	For years 90 - 93 Use existing holes B, C
Pickup, excl. 98 - 06 flare side	For years 94 - 09 Use existing holes B, C, D
Tribute	Use existing holes A, B, D
Nissan	
Pickup and Frontier with 56" bed	Use existing holes B, D
Pickup and Frontier with 75" bed	Use existing holes A, B, C
Plymouth	
Trail Duster	Use existing holes B, D
Voyager	Use existing holes A, D
Toyota	
Pickups, 8' bed, excl. T-100	Use existing holes A, C
Tundra	Use existing holes A, C

HOLE SELECTION (CONTINUED)

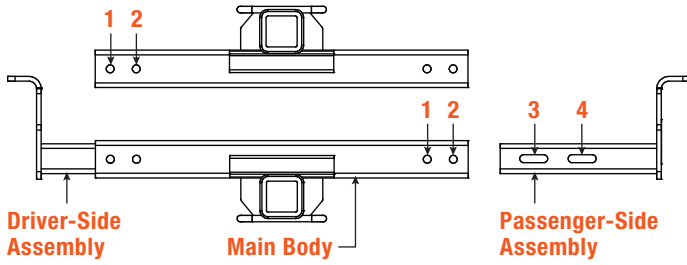

Reference Diagram for Locations	
31" to 33 1/2" frame	Use holes 1 and 4
35" frame	Use holes 2 and 4
37 1/2" frame	Use holes 1 and 3
39" frame	Use holes 1 and 3
41" frame	Use holes 2 and 3

ASSEMBLY

Parts List		
Qty	Description	#
1	Fishwire, 1/2"	1
2	Hex bolt, 1/2" - 13 x 3 1/2"	2
8	Lock washer, 1/2"	3
8	Hex nut, 1/2" - 13	4
6	Hex bolt, 1/2" - 13 x 1 1/2"	5
6	Flat washer, 1/2"	6

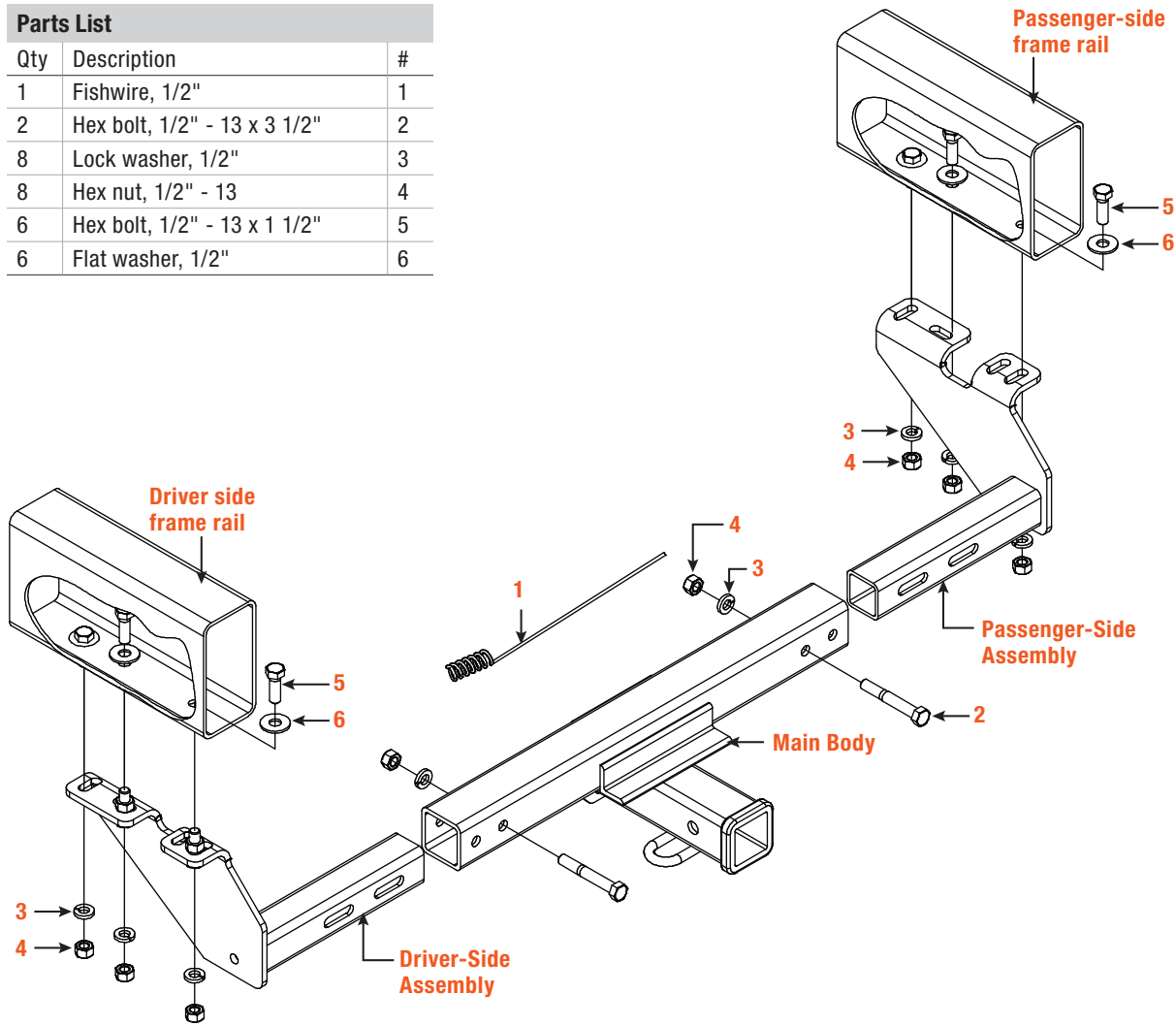

INSTALLATION

Step 1

Measure center-to-center distance of frame rails.

Reference the 'Hole Selection' tables and figures on pages 2 and 3 to determine which holes to use.

Step 2

Some vehicles may have one or two holes in the frame to help locate the hitch. Use the hole(s) in the frame and drill holes A, B, C or D as recommended on the vehicle application listing on page 2.

On vehicles without frame holes, hold the hitch up to the frame using C-clamps, then mark and drill holes in the frame.

On some vehicles (mostly Ford) the frame may have a rivet which interferes with the installation. Remove the rivet and use the hole to bolt the hitch to the frame if desired or bolt to the frame using holes A, C and D.

On Chevrolet and GMC full-size vans, remove and discard the bumper bracket before installing hitch.

On Chevrolet and GMC mini-vans, place driver- and passenger-side frame rails between bumper bracket and frame.

For 1993 - 1997 Chevrolet Astro van, see diagram below.

Note: Installation of some models may be easier if spare tire is removed during installation. On Ford trucks, the spare tire bracket must be removed or adjusted before installing hitch.

Side view of Chevrolet Astro van installation

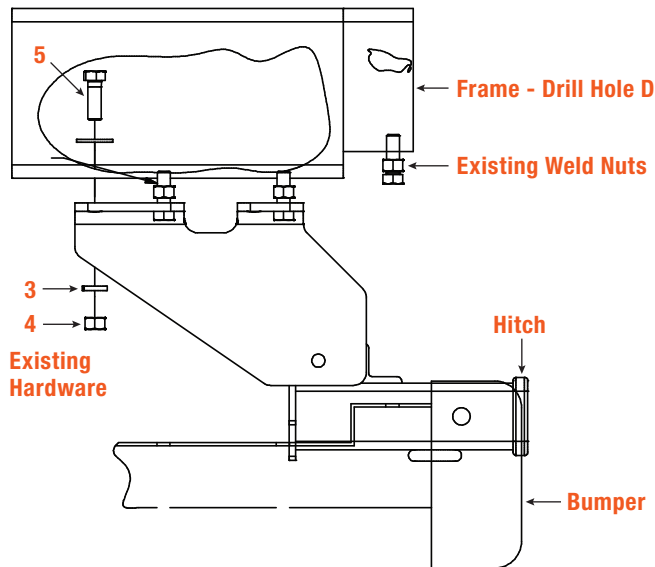

Step 3

Bolt the driver side plate to the frame using 1/2" x 1 1/2" bolts (#5), flat washers (#6), lock washers (#3) and 1/2" nuts (#4), tighten firmly.

Step 4

Slide the main body assembly over the driver-side plate insert. Slide the passenger-side insert into the main body.

Note: Main body assembly can be reversed for use on Ford vans.

Step 5

Align the holes in the driver-side plate insert with the holes in the main body assembly and secure with 1/2" x 3 1/2" bolts (#2), lock washers (#3) and 1/2" nuts (#4).

Step 6

Align the holes in the passenger side plate insert with the holes in the main body assembly and secure with 1/2" x 3 1/2" bolts (#2), lock washers (#3) and 1/2" nuts (#4).

Step 7

Hold hitch up to frame and bolt passenger side plate to frame using 1/2" x 1 1/2" bolts (#5), flat washers (#6), lock washers (#3) and 1/2" nuts (#4).

Step 8

Torque all 1/2" fasteners to 64 lb-ft. To ensure proper installation, the driver side and passenger side insert tubes must be drawn together with the main body assembly tube to achieve metal-to-metal contact.

FISHWIRE TECHNIQUE

Insert coiled end of fishwire tool through hitch mounting hole in vehicle frame rail and out the access hole. Pass coiled end of fishwire through spacer and thread bolt into coil. Kink wire to keep spacer separate from bolt as shown. Pull fishwire, spacer and bolt through frame and out mounting hole. Use fishwire to guide hitch during mounting and prevent loss of bolt or spacer inside frame rail.

