

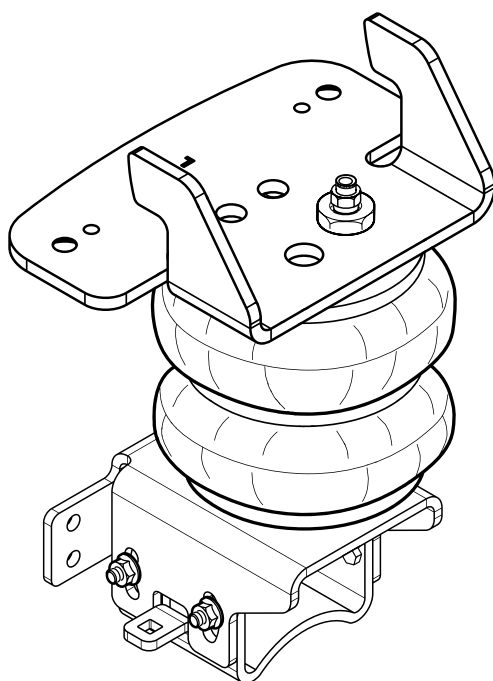

riderite.com

INSTALLATION INSTRUCTIONS



SECTION 1 - AIR SPRING

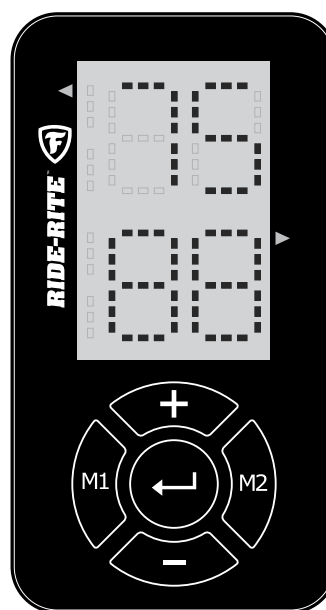

SECTION 2 - AIR COMPRESSOR KIT

Firestone

Firestone Industrial Products

! IMPORTANT

THIS KIT ONLY FITS DUAL-REAR-WHEEL PICKUP TRUCKS. IT WILL NOT FIT SINGLE REAR-WHEEL TRUCKS.

FITS: • 2017 and up Ford F350 4WD with Dual Rear Wheels • 2017 and up Ford F450 4WD Pickup (not Cab and Chassis)

PLEASE DON'T HURT YOURSELF, YOUR KIT OR YOUR VEHICLE. TAKE A MINUTE TO READ THIS IMPORTANT INFORMATION.

DO NOT INSTALL IF THE TRUCK HAS BEEN LIFTED AND THE STOCK JOUNCE BUMPER SPACERS ARE NOT ON THE VEHICLE. *This kit is to be used on a pickup truck only, and DOES NOT INCREASE YOUR VEHICLE'S MAXIMUM LOAD.*

SAFE INSTALLATION

Please take all safety precautions during installation. A hydraulic jack can fail, and if that happens, you can be seriously hurt, or worse, if you are relying on it to hold up the vehicle. If you use a hydraulic jack, secure jack stands in the appropriate locations and chock any tires still touching the ground.

Wear safety glasses or goggles. Your eyes may be lower than some parts and pieces, and you don't want to lose an eye.

Remove the possibility of any electrical issues by disconnecting the negative battery cable.

KIT CLEARANCE

There must be a minimum of 1/2" clearance around all installed components when the air springs are inflated and under a load. The air springs must flex and expand during operation, so the clearance keeps the kit from rubbing against parts of the vehicle.

VEHICLE GVWR

NEVER exceed the maximum load recommended by the vehicle manufacturer (GVWR). The GVWR can be found in your vehicle's owner's manual or on the data plate on the driver's side door. Consult your local dealership for additional GVWR specifications.

INFLATING THE AIR SPRINGS

When inflating air springs, add air pressure in small quantities, checking air pressure frequently. The air springs have much less air volume than a tire, so they inflate much more quickly.

PRESSURE TO LOAD

The air springs will support approximately 50 lbs. of load for each PSI of inflation pressure (per pair). For example, 50 PSI of inflation pressure will support a load of 2500 lbs. per pair of air springs.

APPROPRIATE AIR PRESSURE

For best ride, use only enough air pressure in the air springs to level the vehicle when viewed from the side (front to rear). This will vary, depending on the load, location of the load, condition of the existing suspension, and personal preference.



OPTIONAL T-FITTING

This kit includes inflation valves and air line tube for each air spring, allowing you to compensate for unbalanced loads. If you prefer a single inflation valve system to provide equal pressure to both air springs, your dealer can supply the optional "T" fitting (Part # 3025 or WRI-760-3461 retail pack).

ONCE INSTALLED SUCCESSFULLY, FOLLOW THESE PRESSURE REQUIREMENTS FOR THE AIR SPRINGS:

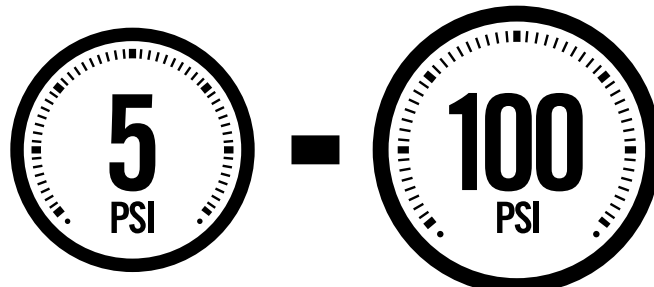





MINIMUM PRESSURE

MAXIMUM PRESSURE (LOADED)

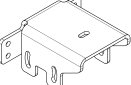
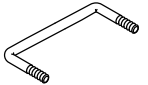
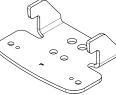
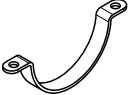

SECTION 1 PARTS

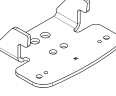
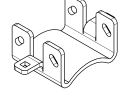
Compare the parts below to your kit. Assure you have all pieces, and organize them for an easier installation.













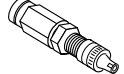

MAIN KIT CONTENTS

PT # 6397	 x2 AIR SPRING	PT # 5878	 x2 LOWER AIR SPRING BRACKET	PT # 3077	 x2 BAIL CLAMP
PT # 5872	 x1 UPPER LEFT BRACKET	PT # 5876	 x2 AXLE STRAP BRACKET	PT # 1004	 x1 HEAT SHIELD
PT # 5873	 x1 UPPER RIGHT BRACKET	PT # 5882	 x2 AXLE SADDLE BRACKET	PT # 9415	 x1 AIR LINE TUBE (22 FEET)

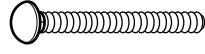
A24-760-7560 INFLATION VALVE BRACKET KIT

PT # 9483	 x1 NO-DRILL INFLATION VALVE BRACKET	PT # 9488	 x2 LARGE NYLON TIE
-----------	---	-----------	---

A21-760-2504 HARDWARE PACK

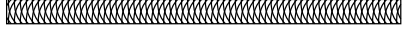
PT # 3370	 x4 3/8" - 16 x 3/4" FLAT HEAD SCREW	PT # 3067	 x12 3/8" - 16 FLANGE LOCK NUT	PT # 3032	 x2 INFLATION VALVE AND VALVE CAP ASSEMBLY
PT # 3033	 x4 5/16" FLAT WASHER	PT # 3493	 x12 3/8" FLAT WASHER	PT # 3055	 x2 AIR FITTING
PT # 3069	 x2 3/8" - 16 x 3/4" FLANGE BOLT	PT # 3332	 x2 5/8" - 18 NYLON JAM NUT	PT # 3482	 x4 3/8" - 16 x 3.5" CARRIAGE BOLT
PT # 3505	 x2 10 - 24 x 2" THREADED ROD	PT # 3504	 x4 3/8" - 16 FRAME NUT	PT # 9036	 x30 RED NYLON TIE
PT # 3338	 x8 3/8" - 16 x 1" HEX HEAD BOLT	PT # 3488	 x4 3/8" - 16 NYLOCK NUTS	PT # 0899	 x2 THERMAL SLEEVE

OPTIONAL ITEMS

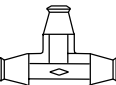
PT # 3025	 x1 T-FITTING
-----------	--

Visit riderite.com to find the perfect air accessories for your kit.

CONTENTS AND OVERVIEW

SECTION 1

PAGE **4** REMOVE JOUNCE BUMPER & INSTALL FRAME NUTS

PAGE **5** INSTALL UPPER BRACKET

PAGE **6** FASTEN AIR SPRING TO UPPER BRACKET

PAGE **7** INSTALL LOWER BRACKET ASSEMBLY

PAGE **8** SECURE LOWER BRACKET ASSEMBLY

PAGE **9** HEAT SHIELD & PASSENGER SIDE

PAGE **10** AIR LINE TUBE & INFLATION VALVE INSTALLATION

PAGE **11** INSTALL & ROUTE AIR LINE TUBE

PAGE **12** CHECKING THE SYSTEM

PAGE **13** FIXING AN AIR LEAK

PAGE **14** FINISHING THE INSTALLATION

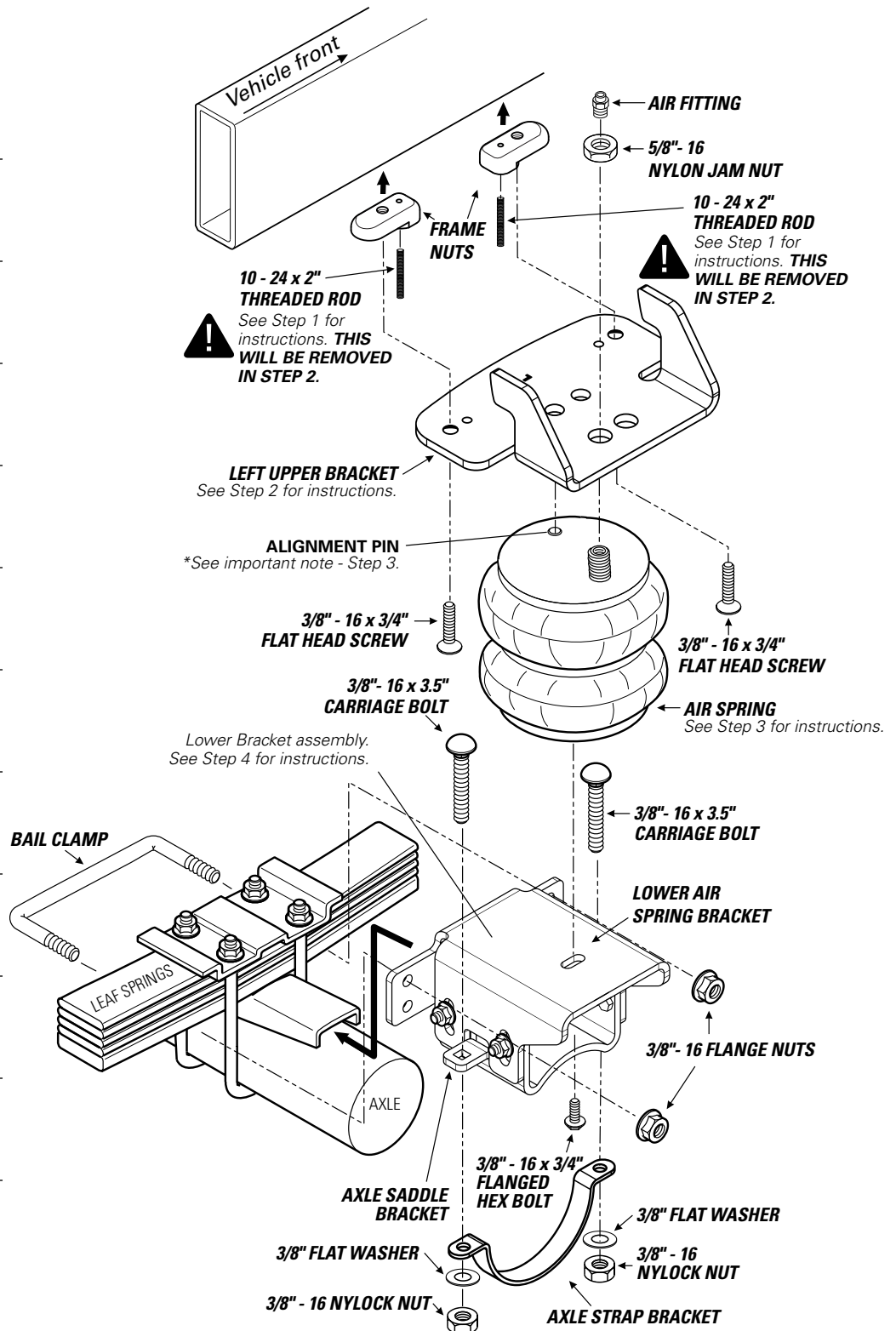

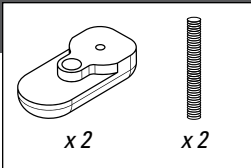

START THE INSTALLATION ON THE LEFT SIDE OF THE VEHICLE WHEN FACING FORWARD.

1 Remove the jounce bumper and the two studs holding it on. The two studs can be pried out with a flat head screw driver.

2 Thread the 10 - 24 x 2" threaded rods onto the frame nuts. These act as a grip to assist in installation.

3 Insert the frame nuts into the hole in the frame where you removed the jounce bumper studs, seating the frame nuts so they are flush with the vehicle frame.

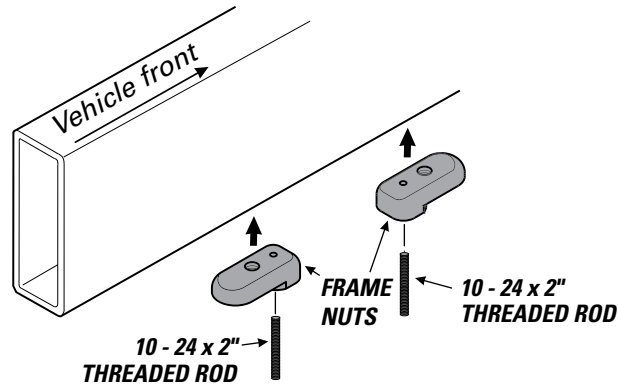

VIEW FROM BELOW

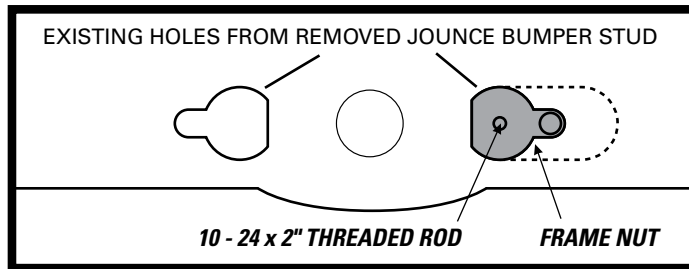

VIEW FROM SIDE

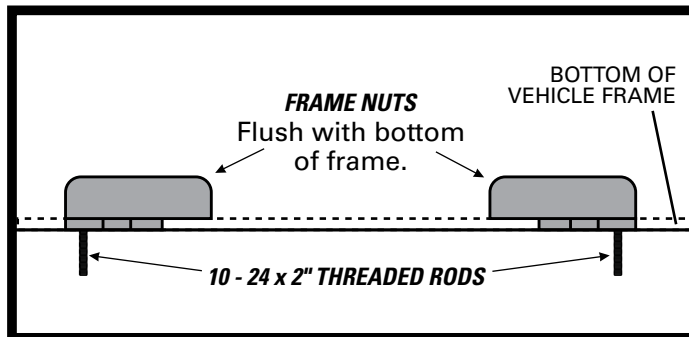

2

INSTALL UPPER BRACKET

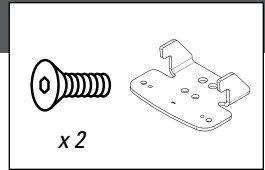

1 Using the threaded rods as guides, slide the upper bracket into place and secure against the bottom of the vehicle frame.

2 Fasten upper bracket to the frame using the flat head screws, as shown.

3 Remove the threaded rods and save them for installation on the other side of the vehicle.



REMOVE THREADED RODS AFTER SECURING THE UPPER BRACKET. FAILURE TO DO SO COULD CAUSE THEM TO PUNCTURE THE AIR SPRING, RESULTING IN AN AIR SPRING FAILURE THAT IS **NOT WARRANTABLE.**

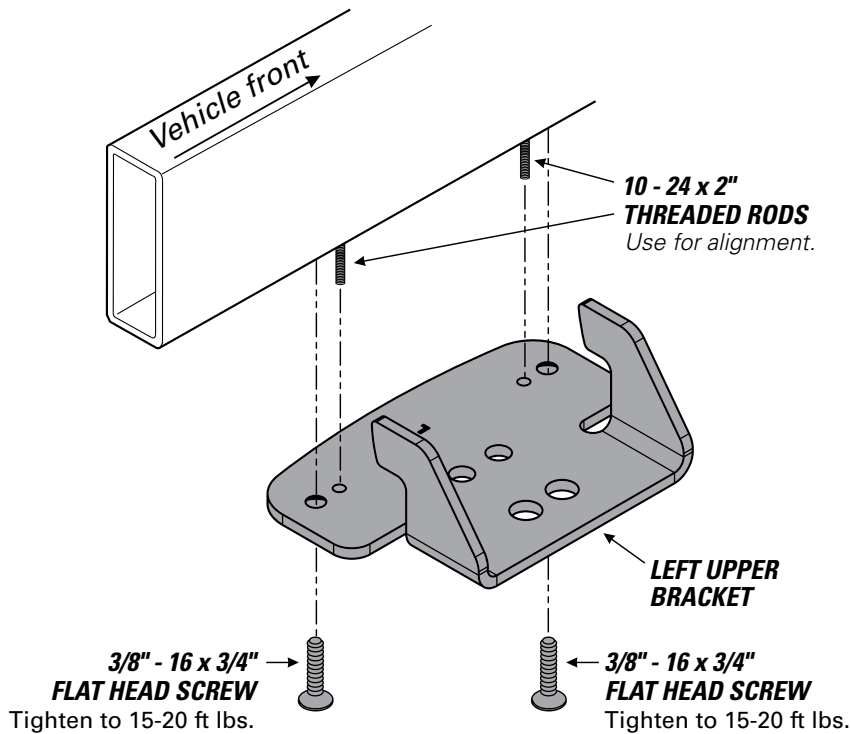

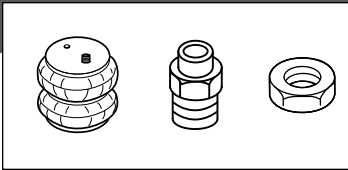

INSTALLING THE RIGHT SIDE? REMEMBER TO INSTALL THE HEAT SHIELD IN STEP 6 FIRST!

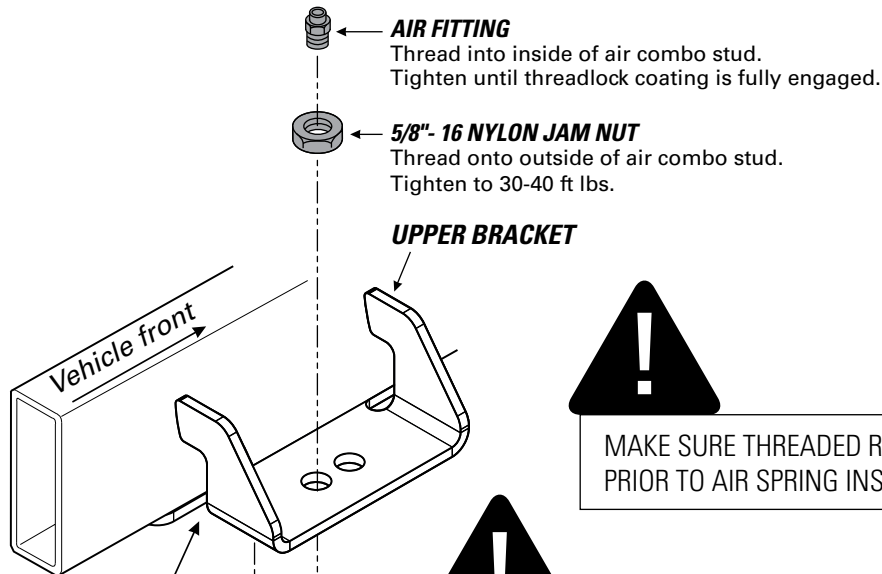

MAKE SURE THREADED RODS ARE REMOVED PRIOR TO AIR SPRING INSTALLATION.

VIEW FROM BELOW

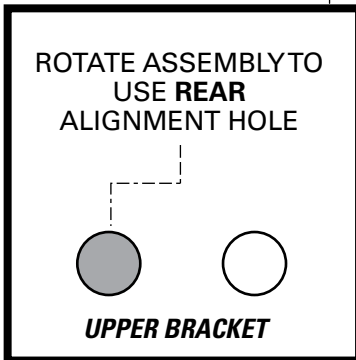

ALIGNMENT PIN ON AIR SPRINGS MUST BE INSTALLED TO FULLY SEAT INTO THE FRONT ALIGNMENT HOLE IN THE UPPER BRACKET. FAILURE TO DO SO WILL CAUSE IT TO BE PUSHED INTO THE BEAD PLATE, CREATING AN AIR LEAK, AND RESULTING IN AN AIR SPRING FAILURE THAT IS **NOT WARRANTABLE. THE ALIGNMENT PIN CANNOT HOLD 2,500 LBS! IT IS USED FOR ALIGNMENT ONLY!**

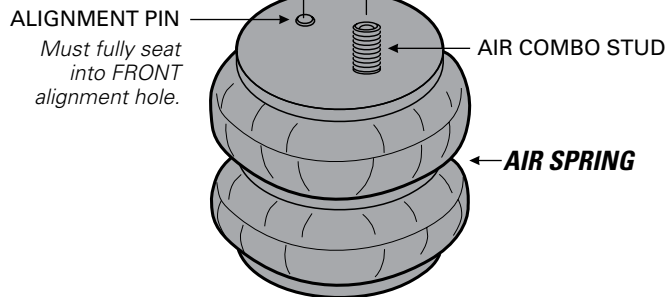

4

INSTALL LOWER BRACKET ASSEMBLY

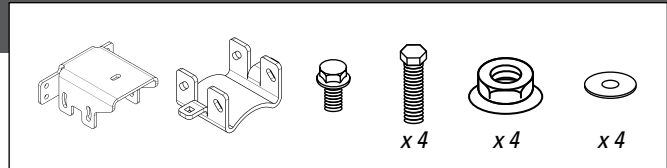

1 Follow steps below to dry fit assembly. Make alignment marks as shown.

2 Place bottom of axle saddle bracket on the axle of the vehicle.

3 Place the upper bracket above the axle saddle bracket as shown. Assure both are tight against the leaf spring stack.

4 Match the alignment marks and secure the air spring to the upper bracket, as shown.

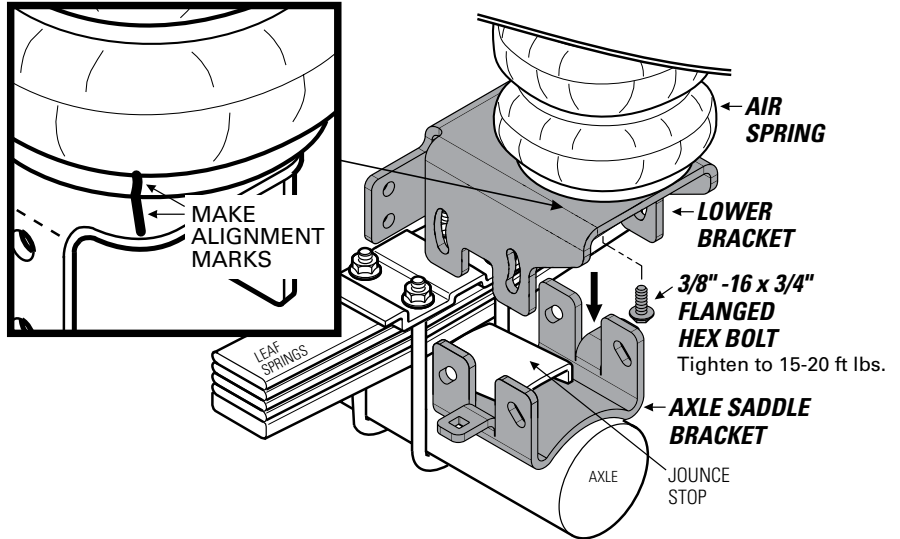

5 Position the lower bracket **as low as possible**, while still clearing the jounce stop on the vehicle. See figure below for design height.

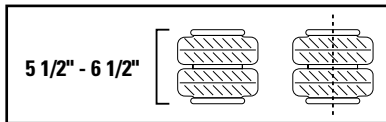

6 Making sure the lower bracket is parallel to the ground, insert the bolts from the inside of the lower bracket assembly.

7 Use supplied fasteners to secure the lower bracket to the axle saddle bracket for form the lower bracket assembly.

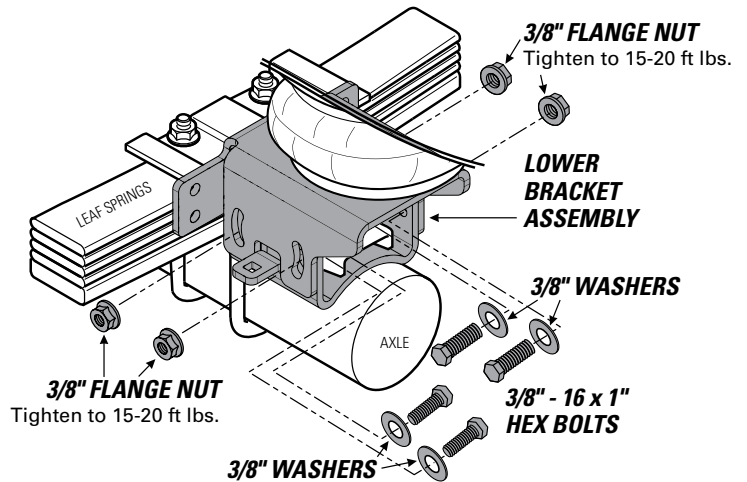

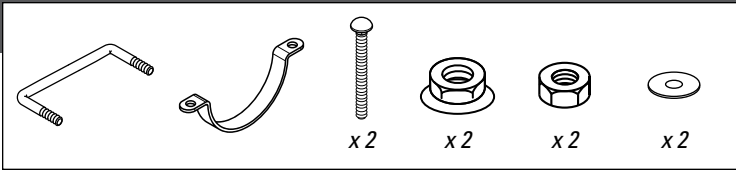

!

USE YOUR HAND TO CHECK FOR THE PROPER CLEARANCE AROUND THE AIR SPRING. IF YOUR HAND DOES NOT FIT BETWEEN THE AIR SPRING AND OTHER COMPONENTS, IT WILL RUB!

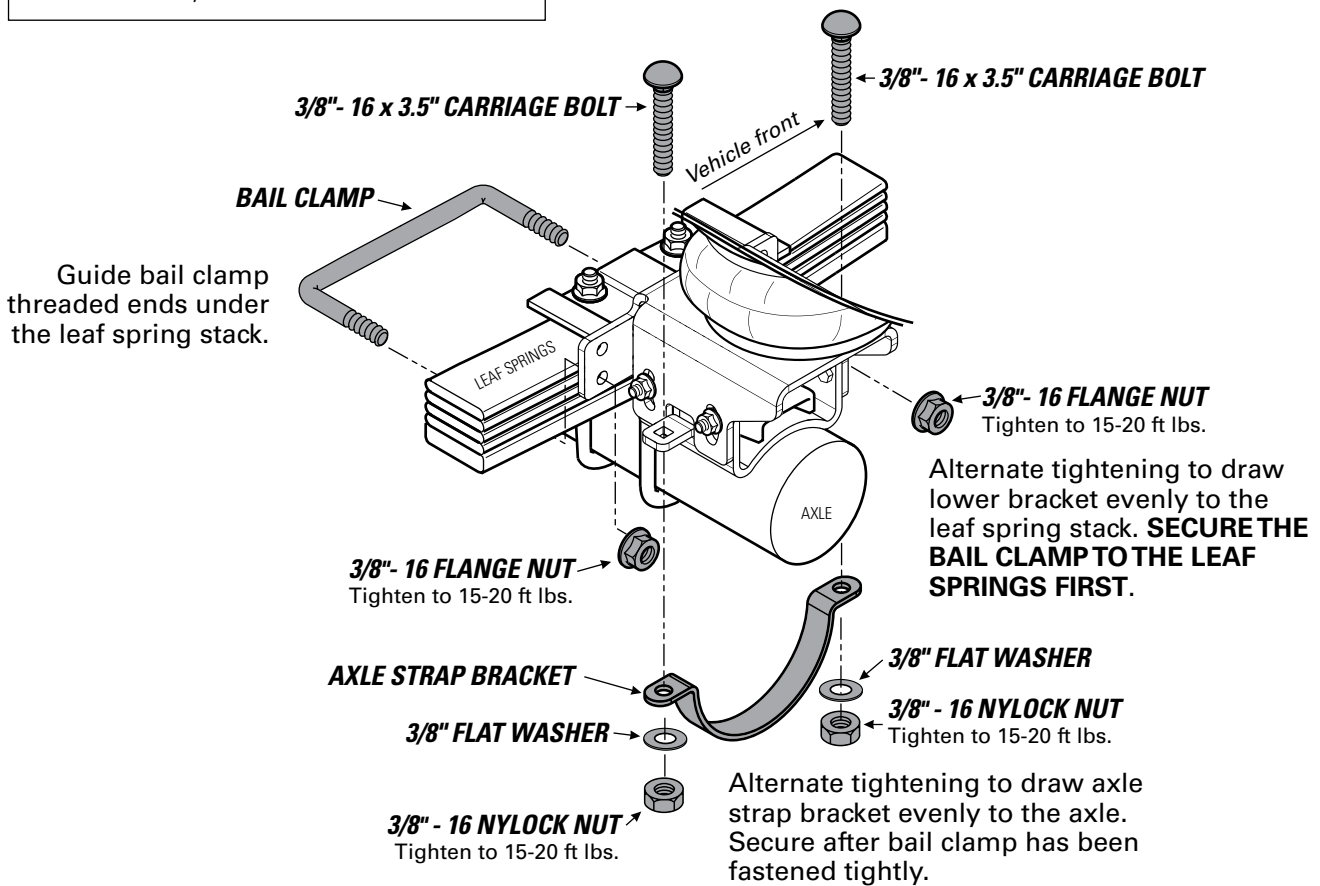
AWESOME! You're done with the left side. The right side is the same, with the addition of the heat shield. See Step 7, then complete the steps for the right side installation.

6

INSTALL RIGHT SIDE WITH HEAT SHIELD



RIGHT SIDE INSTALLATION MUST INCLUDE HEAT SHIELD!

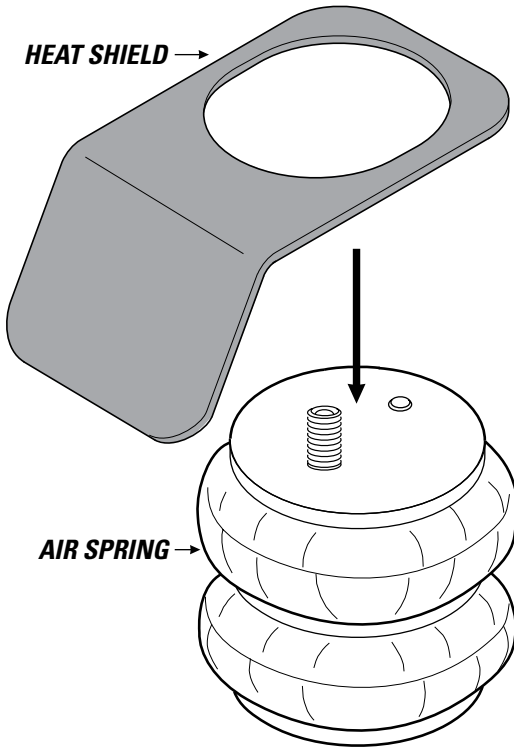

MAKE SURE THREADED RODS ARE REMOVED, SHOWN IN STEP 2.

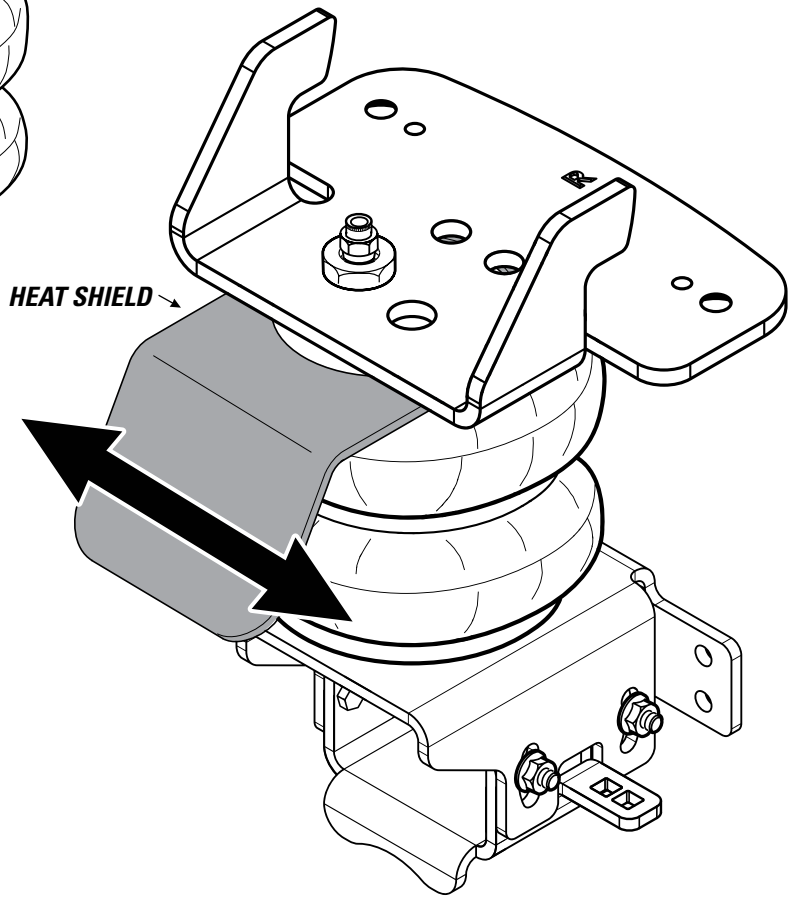

Position heat shield to closest point of exhaust. DO NOT PLACE DIRECTLY ABOVE AXLE.







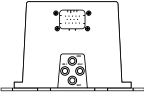
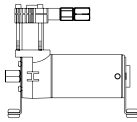
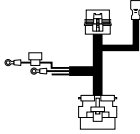
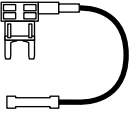
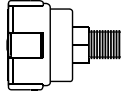

SECTION 2 PARTS

Compare the parts below to your kit. Assure you have all pieces, and organize them for an easier installation.

AIR ACCESSORY CONTENTS

PT # 9490		x1 WIRELESS CONTROLLER	PT # 9489		x1 ECU	PT # 9523		x1 AIR COMPRESSOR
PT # 9491		x1 WIRE HARNESS	PT # 7543		x1 IGNITION FUSE TAP	PT # 9129		x1 AIR FILTER

AIR ACCESSORY HARDWARE PACK

PT # 3087		x4 10-32 x 1" MACHINE SCREW	PT # 3093		x3 10-32 x 3/4" MACHINE SCREW	PT # 3086		x13 3/16" FLAT WASHER
PT # 3088		x9 10-32 NYLOCK NUT	PT # 9275		x4 VELCRO TABS	PT # 9361		x1 SEALED RELAY
PT # 3421		x1 10-16 x 3/4" SELF-TAPPING SCREW	PT # 0899		x2 THERMAL SLEEVE	PT # 9488		x4 LARGE NYLON TIE

CONTENTS AND OVERVIEW

SECTION 2

PAGE **12** PLANNING THE INSTALL

PAGE **13** PREPARE THE AIR COMPRESSOR

PAGE **14** DRILL HOLES FOR AIR COMPRESSOR AND ECU

PAGE **15** INSTALL THE AIR COMPRESSOR AND ECU

PAGE **16** INSTALL THE WIRE HARNESS

PAGE **17** INSTALL THE AIR LINE TUBES

PAGE **18** INSTALL THE AIR FILTER AND CLEAN UP

PAGE **19** USING THE WIRELESS CONTROLLER

PAGE **20** FREQUENTLY ASKED QUESTIONS

PAGE **21** TEST THE SYSTEM

PAGE **22** FIX AN AIR LEAK

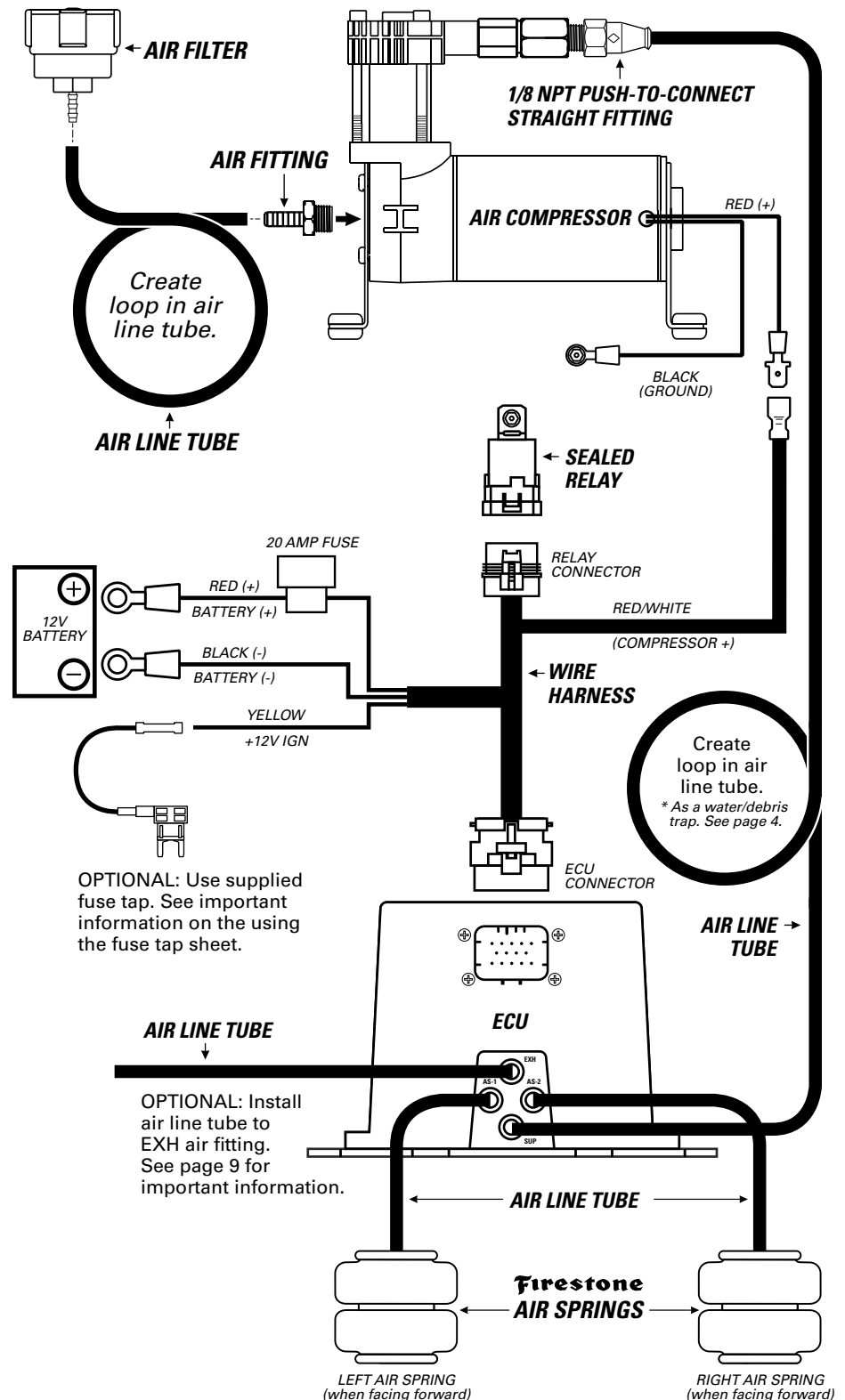

PLANNING THE INSTALL

THESE PLANNING STEPS WILL HELP YOU SAVE TIME AND WILL MAKE THE INSTALLATION EASIER.

DETERMINE THE MOUNTING LOCATION FOR THE AIR COMPRESSOR

- Provides ample air flow and is protected from airborne debris and moisture.
- Mount close enough to the ECU to allow wire harness connections to reach.
- If using the optional Firestone air accessory mounting kit, consider the guidelines above, and follow the kit's instructions.

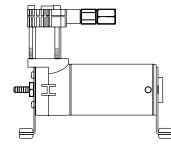

DETERMINE THE MOUNTING LOCATION FOR THE ECU

- Mount close enough to the air compressor to allow wire harness connections to reach.
- Allow room for air line tubes to connect to the air fittings on the ECU.
- Allow room for the 14-pin ECU connector to connect to the ECU.
- Allow room for the air line tube to run without sharp curves or bends.
- Using supplied fasteners shown in Step 3 is recommended. If no other mounting option is available, see the sidebar on Step 2 for using the large Nylon ties.
- Select a location that is solid and secure on the body or frame of the vehicle, away from any moving parts, electrical or any other lines.

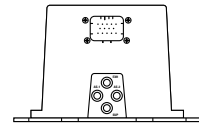

PLAN INSTALLATION ROUTES FOR WIRING AND AIR LINES

- Make sure the wire harness and air line tubes are not exposed to sharp metal edges that can damage them.
- Use supplied thermal sleeves on air line tubes when routing near heat sources.
- Use supplied Nylon ties to secure air line tubes and wire harness to the vehicle.
- Make a loop in the air line tube where shown. This creates a water/debris trap that protects the air compressor.
- Measure twice, cut once!

TAPE ALL ELECTRICAL CONNECTIONS

- Use electrical tape to appropriately secure and protect all electrical connections.

USING PUSH-TO-CONNECT FITTINGS FOR AIR LINES

Your kit includes push-to-connect fittings to connect the air line tubes to hardware. Use the instructions below when using the air line tubes.

- 1** Insert end of air line tube into air fitting.

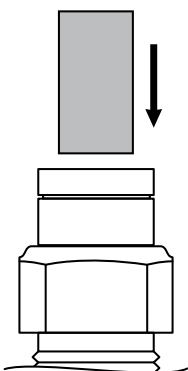

- 2** Push air line tube into air fitting as far as possible.

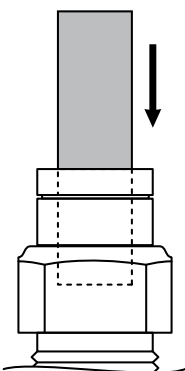

- 3** Gently pull on the air line tube to check for a secure fit.

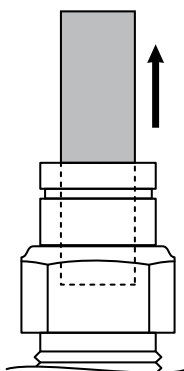

- 4** To remove, push down collar and gently pull air line tube away.

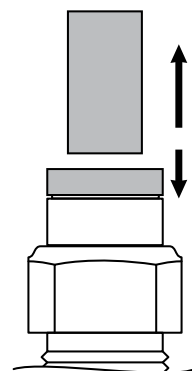

Removal Tip: Use a 1/4", 5/16", or 6mm open-ended wrench to push the collar down.

1

PREPARE THE AIR COMPRESSOR

NOTE: Air Compressor can be mounted facing any direction.

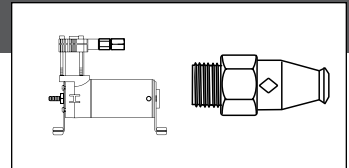

- 1 Install 1/8 NPT Push-to-Connect Straight Fitting on the Check Valve.

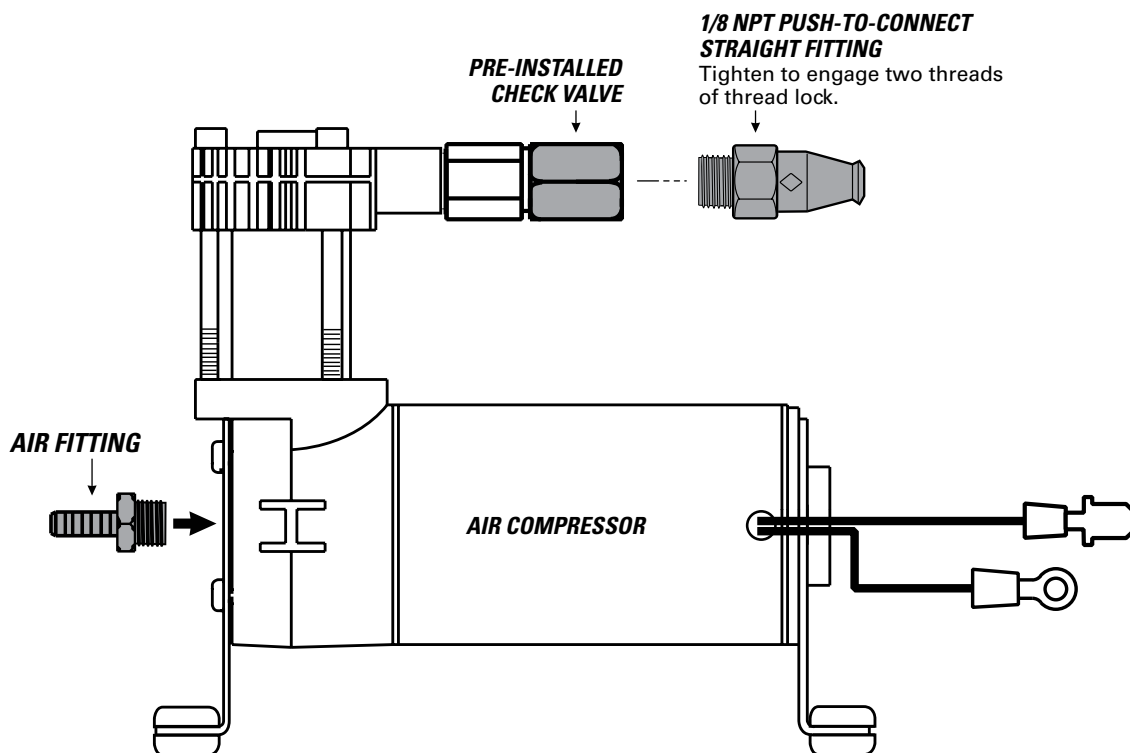

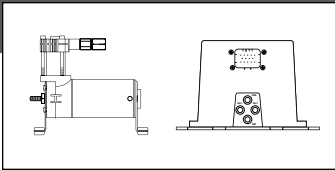

CHECK SURROUNDING AREA AND BACK SIDE OF MOUNTING LOCATION TO AVOID DRILLING INTO EXISTING LINES OR WIRING.



IF YOU ARE USING THE OPTIONAL FIRESTONE AIR ACCESSORY MOUNTING KIT, SKIP THIS STEP AND REFER TO THE MOUNTING KIT'S INSTRUCTIONS.

Drill within reach of the ground wire ring terminal on body or frame of vehicle. **AIR ACCESSORY MOUNTING KIT CANNOT BE USED AS A GROUNDING LOCATION FOR THE AIR COMPRESSOR.**

1 Using the air compressor and ECU as templates, mark drill locations as shown with a punch or marking tool.

2 Mark air compressor ground wire fastening location within reach of the ground wire ring terminal.

3 Drill 3/16" diameter holes. Remove any burrs and debris from drill holes.

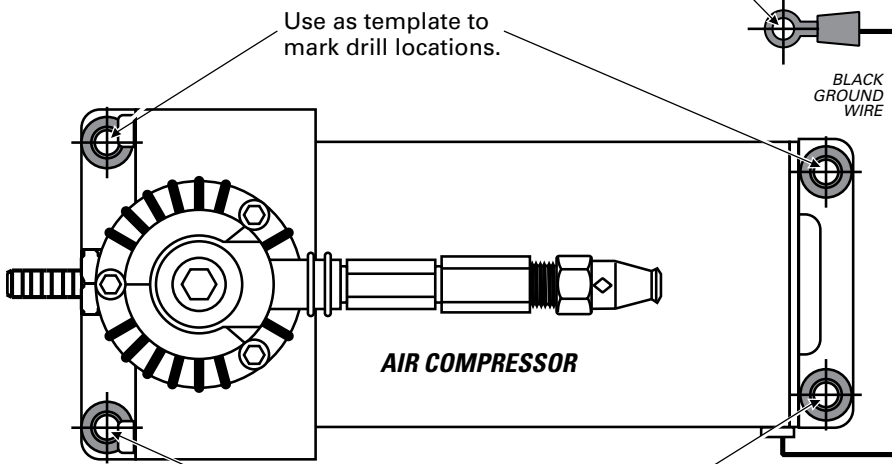

ASSURE THAT YOU INSTALL THE AIR COMPRESSOR AND ECU CLOSE ENOUGH SO THE CONNECTORS ON THE WIRE HARNESS WILL REACH THEM BOTH.



Use as template to mark drill locations.

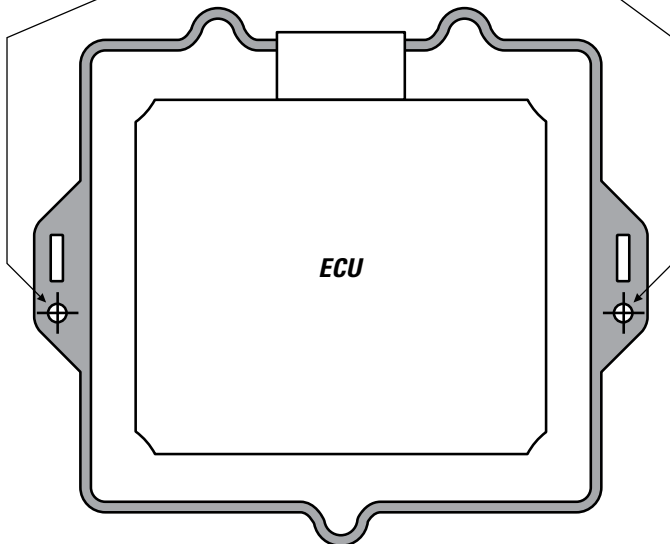

OPTIONAL ECU MOUNTING

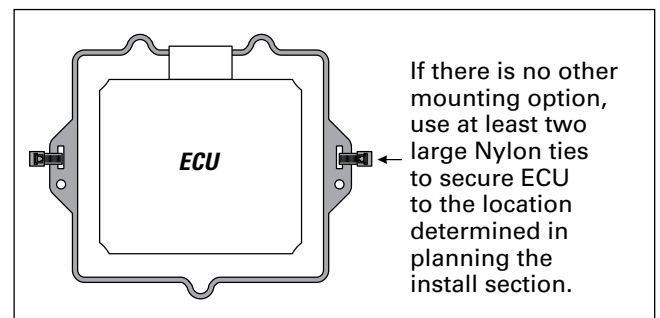

3

INSTALL THE AIR COMPRESSOR AND ECU

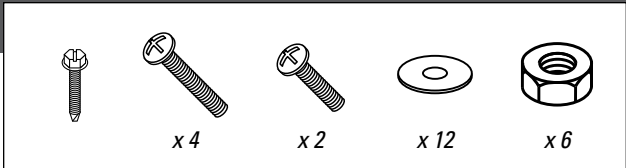

DO NOT OVER TIGHTEN MOUNTING BOLTS AND NUTS ON THE AIR COMPRESSOR. TOO MUCH TORQUE CAN CRUSH THE BRASS INSERTS AND RUBBER ISOLATORS.

1 Mount the air compressor to the drill hole location using the supplied fasteners. DO NOT OVERTIGHTEN.

2 Mount the ECU to the drill hole location using the supplied fasteners.

3 Mount the black ground wire ring terminal using the supplied fasteners. Assure that the ring terminal makes a solid contact with bare metal for a proper ground.

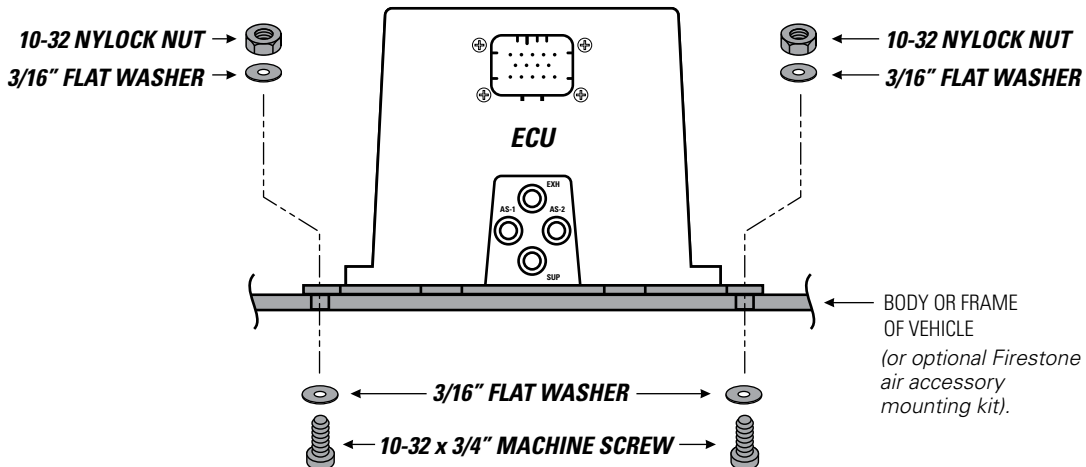
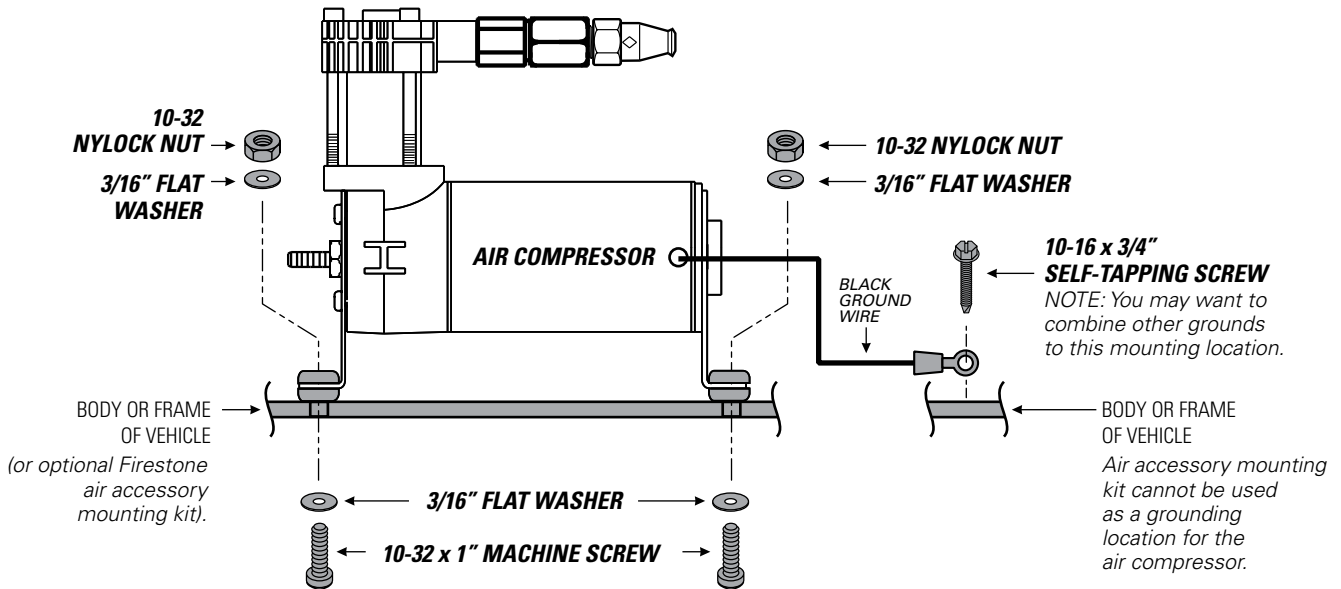

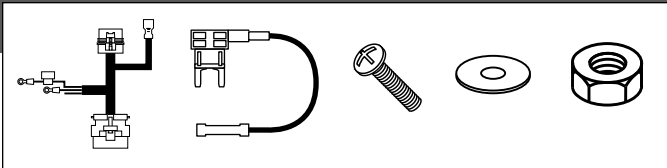

Why ground the wire harness to the battery? The ECU needs a good, clean ground for optimal accuracy. The air compressor can ground to the frame, but the ECU cannot.

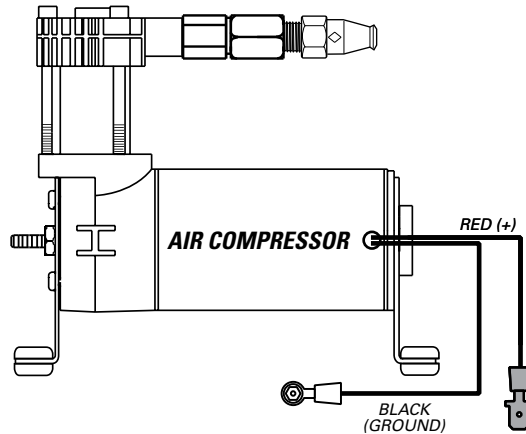

10-32 NYLOCK NUT
3/16" FLAT WASHER
10-32 x 3/4" MACHINE SCREW

SEALED RELAY

Drill 3/16" hole in suitable location on vehicle (or use optional Firestone air accessory mounting kit).

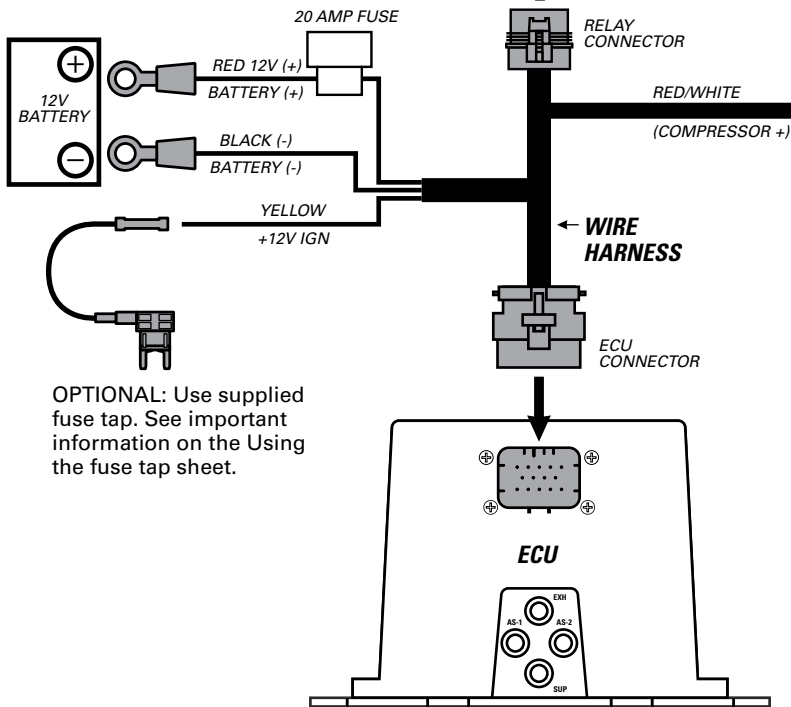

OPTIONAL: Use supplied fuse tap. See important information on the Using the fuse tap sheet.

1 Determine a suitable location to mount the sealed relay, assuring it will be within reach of the relay connector on the wire harness.

2 Securely fasten the sealed relay as shown.

3 Route the wire harness in the most protected manner possible, and securely make all connections as shown.

TAB CONNECTOR EXAMPLE

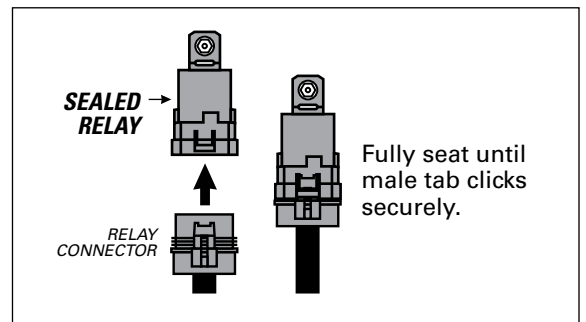

5

INSTALL AIR LINE TUBES



EXHAUST ALL AIR FROM THE SYSTEM PRIOR TO RELEASING AIR TUBES FROM AIR FITTINGS.



1 Route the air line tube from 1/8 NPT push-to-connect straight fitting on the top of the air compressor to the supply (SUP) air fitting on the ECU, leaving room to secure it safely. Use the guidelines on page 4 for proper push-to-connect straight fitting install.

2 Repeat Steps 1 to route air line tube from the ECU to the air springs. Use the AS-1 and AS-2 air fittings on the ECU.

3 If desired, install air line tube to the exhaust (EXH) air fitting to reduce exhaust noise and prevent dirt from clogging the port (recommended for off-road or dirty environments). Do not exceed 16" of air line tube, and secure it so the end turns to the ground.

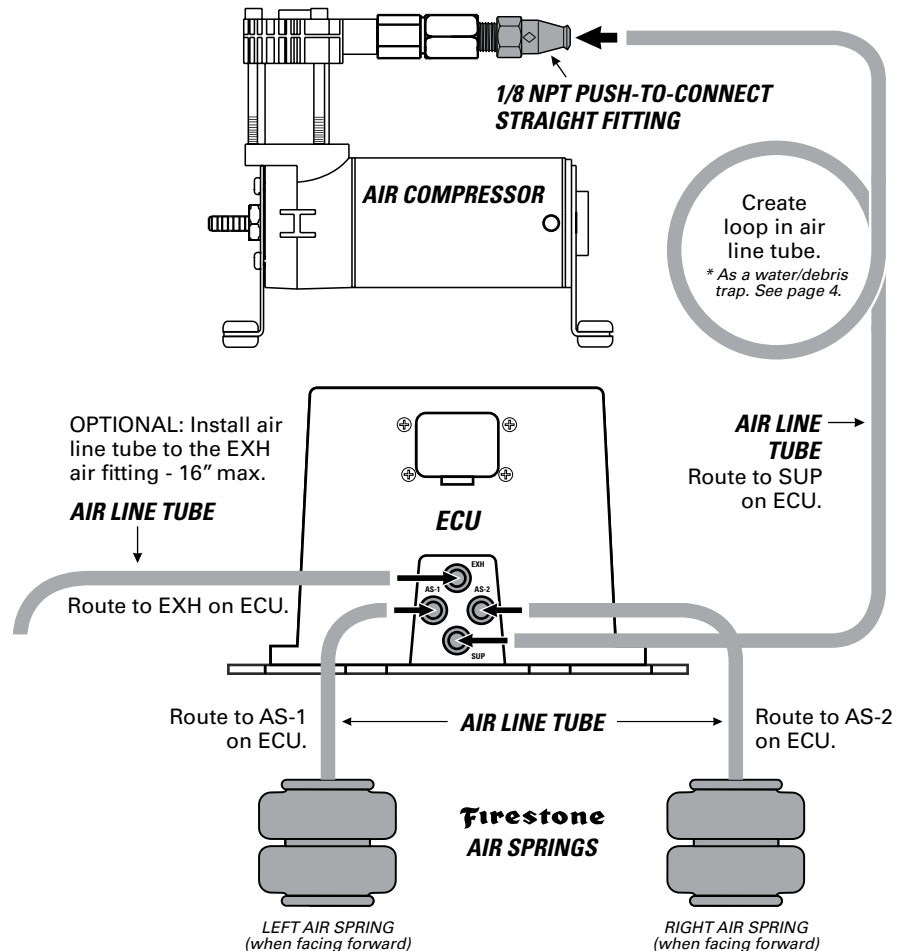

DO

Make sure the cut is as square as possible. Use a tube cutter or very sharp utility knife.

DON'T

Fold or kink the air line tube. Cut the air line tube at an angle. Use pliers, scissors, snips, saws, or side cutters.

PROPER AND IMPROPER CUTS IN THE AIR LINE TUBE

<p>Square cut AIR LINE TUBE 90°</p>	<p>AIR LINE TUBE</p>	<p>AIR LINE TUBE</p>	<p>AIR LINE TUBE</p>
---	----------------------	----------------------	----------------------

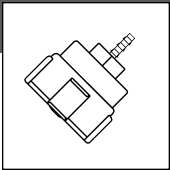

FILTER LIFE WILL VARY BASED ON ENVIRONMENTAL CONDITIONS. PROTECT THE AIR COMPRESSOR BY CHANGING THE AIR FILTER MORE FREQUENTLY IN DUSTY CONDITIONS.

1 Fully secure the air filter barb into the air line tube from the air compressor kit.

2 Press air line tube onto the barb on the air compressor air fitting until fully seated. Assure you create a loop in the air line tube, as shown, when securing it to the vehicle.

3 Periodically check the air filter during operation. When the air filter is dirty and needs to be replaced, contact an Authorized Firestone dealer to purchase a new one.

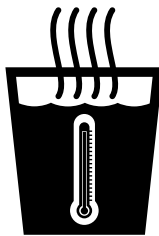

FOR PROPER INSTALLATION, SOAK AIR LINE TUBE ENDS IN HOT WATER BEFORE INSTALLING ONTO BARBED FITTINGS.

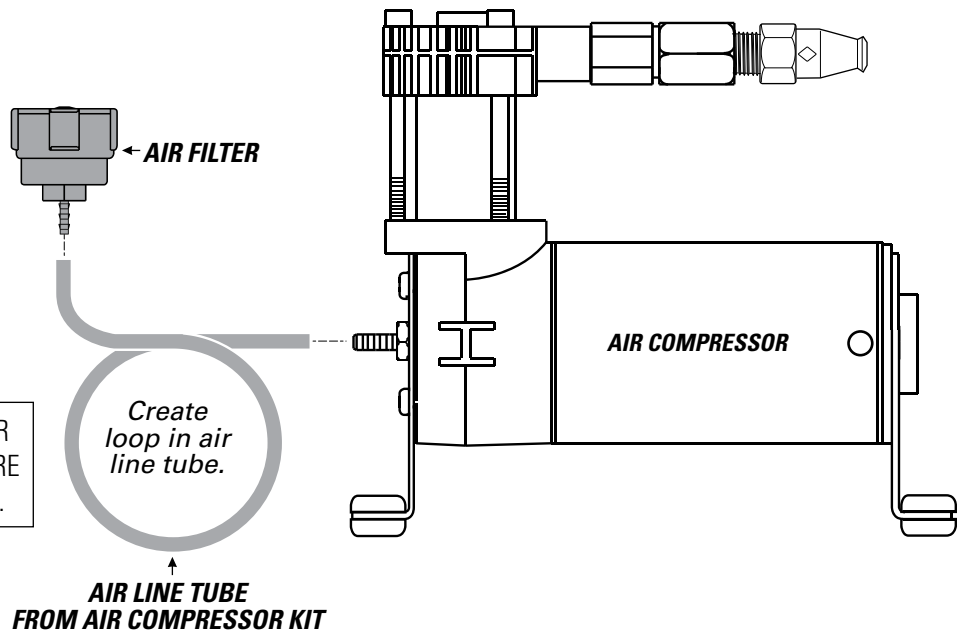

1 Clean up the installation using supplied Nylon ties, and return all factory parts and materials to operative state.



USING SUPPLIED NYLON TIES, SECURE ALL WIRING AND AIR LINE TUBE IN A MANNER THAT DOES NOT OBSTRUCT MOVING PARTS OR IN ANY WAY THAT AFFECTS YOUR ABILITY TO SAFELY OPERATE THE VEHICLE.

Use the wireless controller to adjust the air pressure in your air springs. You can select the air springs individually, or both at the same time. Determine sides when in vehicle, facing forward. If desired, use the supplied Velcro tabs to secure the remote to the vehicle.



F3 REMOTE FUNCTIONS

On/Off

Press **Enter** to turn on remote. Hold **Enter** button for 3 seconds to turn off remote.

Inflating/Deflating Pressure for Both Air Springs

Turn on the remote to enter the main menu. Press **Enter** to adjust both air springs. Adjust pressure by pressing **(+)** or **(-)** button to desired pressure setting. Press the **Enter** button when desired setting is reached.

Inflating/Deflating Pressure for Individual Air Springs

Turn on the remote to enter main menu. Press **Enter** to adjust both air springs. Press **Enter** again to adjust individual air springs. Adjust pressure by pressing **(+)** or **(-)** button to the desired pressure setting. Press the **Enter** button when the desired setting is reached.

2 Memory Button Settings

Press **M1** or **M2** button. Preset pressure should appear. M1 is preset to 5 PSI. M2 is preset to 20PSI. Press the **Enter** button again to adjust pressure. To change the preset pressure, press **M1** or **M2**. Change the preset pressure by pressing **(+)** or **(-)** button. To save the pressure setting to memory, press and hold **Enter** button for 3 seconds. The display will flash rapidly to indicate the new pressure setting is saved. After saving the new pressure, the menu will revert to main menu.

Changing Units to PSI/BAR

Press **(+)** and **(-)** buttons together for 3 seconds. Once in the unit measurement menu, press **(+)** for PSI and **(-)** for BAR. Press **Enter** again to save the desired unit measurement and revert back to main menu.

Tank Mode

To convert to Tank Mode, unplug power to the ECU, install the tank and repower the ECU. The system will automatically enter Tank Mode.

Tank Mode Menu

Press and hold **M1** and **M2** buttons for 3 seconds to enter Tank Mode. While in Tank Mode, **T** will appear on the top row and the current tank pressure on the bottom row. Preset tank pressure range is 110-145/90-120. M1 is preset to 110/145. M2 is preset to 90/120. *Note: In Tank Mode, it is not advised to set air springs above Tank Pressure lower limit. User should first raise the lower limit threshold to a higher range before increasing pressure in air spring.*

F3 REMOTE ERROR CODES

Error Definition

Communication Error: An error message **E/CN** will display if communication from the ECU to the remote is not established for 2 seconds.

Leak Error: The remote will display **EL** in the top row if a leak is present and either **t**-tank, **L**-left air spring or **r**-right air spring on the bottom row to notify which component is leaking.

Bad Pressure Sensor: The remote will display **EP** in the top row if a bad pressure sensor is present and either **t**-tank, **L**-left air spring, **r**-right air spring in the bottom to notify which component has the bad pressure sensor.

Compressor Error: The remote will display **EC** on the top row if the compressor exceeds 4 minutes of runtime.

Low Battery: The remote will display **Lo Bt** on the display if batteries are below the rated voltage of 3.0 V. *Note: when the low battery indicator is present, the remote will be unable to save the last setting by the user.*

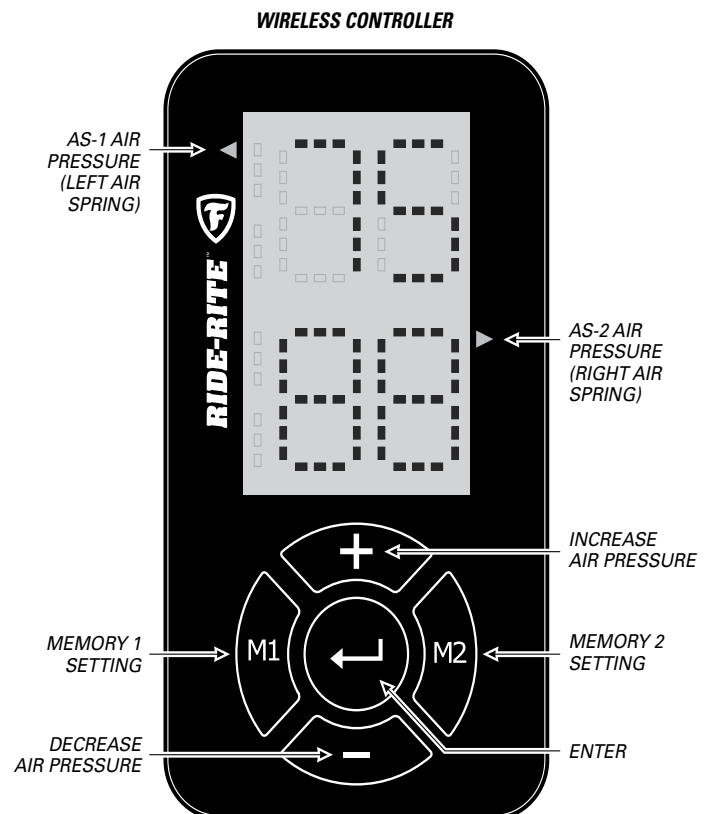

1) Why is my system not powering up?

When the system does not power up, usually this is a strong indication of improper power and grounding. Ensure that the power line (red wire) is attached to a +12 volt power source (battery). The grounding line (black wire), should be rerouted back to the battery, not the frame of the car. Traditionally, techs have used the frame the car as a grounding source, but through experience, we have seen that using the true ground (battery) offers the best connection for the device. Next, ensure that the yellow line is connected to the ignition fuse located in your vehicles fuse box. Please make sure the fuse on the F3 wiring harness is installed and not blown. It is important to confirm with a meter (if possible) that the fuse is on only when the ignition is engaged and off when the ignition is off.

2) Why are my buttons not responding correctly?

When your remote controller appears to not operate as intended, some of the key items you need to check are: battery charge (+3v), proper connection to the ECU, EC/N Code (refer to #7), barriers that are in between the ECU and the remote, proper powering (refer to #1).

3) Why is my compressor not shutting off?

When your compressor stays on even after the ignition switch has been placed to the off position, please ensure that the yellow line is tied to a switched fuse in the fuse box. To ensure this, please use a volt meter to confirm that the line is on (+12v), if and only if the ignition switch is in the ON position, and OFF when in the off position.

4) My remote does not work inside my cabin. What should I do?

With the improvements in technology, some cars are equipped with other electronic equipment which may cause interference to the F3 system. Others vehicles are equipped with noise canceling material and equipment which also play a role in the interference of the F3 connectivity. To check if either of these scenarios is true, confirm that your unit works properly if operated outside. If your unit does operate as intended outside the vehicle, contact us for further solutions.

5) Why does my system not turn on when I turn the ignition on?

When your F3 system does not turn on when the ignition switch is on the on position, this is a strong indicator that the unit is not powered/grounded correctly. Please refer to question #1.

6) Why does my remote freeze when I am trying to change pressure?

When your remote is freezing, this is an indication that the communication is out of range/ batteries have insufficient charge or you may have a bad remote. If the batteries are low, replace the batteries. If the communication range is over 30 meters, operate the unit in close proximity. If the issue still persists, contact our tech line to receive a replacement. In order to receive a placement, please have your receipt to show proof of purchase.

7) Why does my remote display "E/CN" when attempting to change pressure?

The "E/CN" code is an indicator that the remote is not communicating to the ECU. When this occurs, this is an indicator that the ECU is not powered or the user is out of range. When the ECU is not powered, please refer to question #1. If the user is out of range, ensure to get within the range of 30meters (98 feet).

8) What should I do when the remote goes to sleep before it meets the set pressure?

Check battery voltage.

9) Is it normal for my compressor to be overworking when attempting to reach pressure?

When the compressor sounds as if it is overworking to get to pressure, relax. This is normal. The ECU was programmed to reach the designated pressure as accurately as possible. To reduce the over usage of the compressor, use the system only when needed. Having two preset settings will reduce the over usage and increase the system lifetime.

10) Why does my compressor run while exhausting continuously?

When the compressor exhausts while running, ensure that the air line connections to the ECU are correct. The ECU has a supply and exhaust line. If the unit is connected backwards, the ECU will attempt to reach pressure, but won't since the connection is improper. If the issue persists after confirming proper connection, check the valves next. The valve could have debris which is not allowing the valves to properly close. If shop air is available, engage the valves with air to free the valves of debris. If the issue persists, please contact tech line for warranty claim.

11) Why does my compressor turn on and run by itself while driving?

If the compressor turns on by itself while the vehicle is in motion and continuously runs, there is a relay that is energized by the battery, and there is a potential wiring harness connection problem. It is possible that the ground terminal of the harness is improperly connected, or has become loose. Please check the connections of the harness to ensure that all terminals are properly connected. If all connections are secure and properly connected, please check the integrity of the relay connection to the compressor. It may be possible that the relay is failing or has failed.

12) Why does my compressor still run when I turn the key off, even when wired to an ignition source?

Please confirm that the following are connected correctly:

- A: The yellow ignition wire is properly connected to the correct fuse that connects to a switched source. There are some fuses that are always powered even when the vehicle's ignition is turned off.
- B: The red power wire is properly connected to the battery, preferably directly to the battery terminal to ensure that the relay is properly energized and reenergized during turn-on, turn-off cycles.
- C: The black wire is properly attached to a ground path. A direct battery connection to the negative terminal is preferred.

13) Why does my compressor run, but dead heads at the ECU?

The compressor usually stops operating if there is an improper connection to the valve body inlets and outlets. If your compressor runs momentarily and then stops, please check the following:

- A: The battery on the vehicle is in good working condition. It has been observed that batteries with insufficient capacities have been unable to withstand compressor demands. Please check your compressor's power rating, and confirm that the battery can meet the voltage and current demands.
- B: Please confirm that the air lines are connected to their proper inlet or outlet valves. This will enable the compressor to properly operate as demanded by the user's input.

14) Why does my controller show a completely different pressure than what is actually in the bags?

When the controller shows a completely different pressure, please contact our tech line for a warranty claim. The ECU contains pressure sensor which can be faulty. Since the sensors are inside the ECU, the unit needs to be replaced.

10

TEST THE SYSTEM

With the Air Command™ F3 Kit and your air springs installed, you are ready to test the system.

- 1** Reattach the negative battery cable.

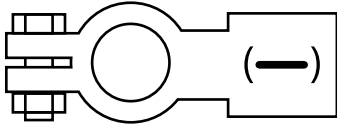

- 2** Turn on your vehicle's ignition.

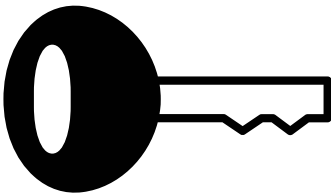

- 3** Use the wireless controller to inflate the air springs to 70 PSI. See Step 8 for details.

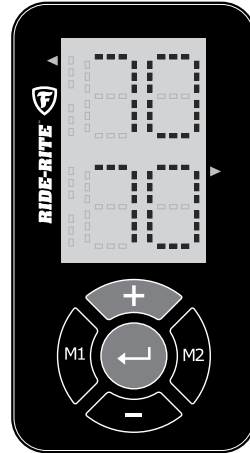

- 4** Spray fittings with soap and water mixture or glass cleaner.



- 5** Observe bubbles.

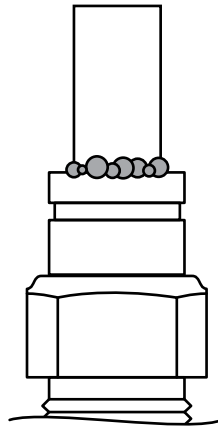

**SMALL SOAP BUBBLES
THAT DO NOT EXPAND**

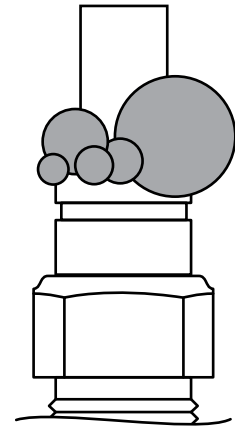

**SOAP BUBBLES
THAT EXPAND**



NO LEAKS?

Congratulations! You're riding right with the push of a button! Remember to review the Operating Instructions.

LEAK?

Bummer. Continue to Step 11 to fix the leak.



EXHAUST ALL AIR FROM THE SYSTEM PRIOR TO RELEASING AIR TUBES FROM AIR FITTINGS.



- 1 Use the wireless controller to deflate the air springs to 5 PSI. See Step 8 for details.

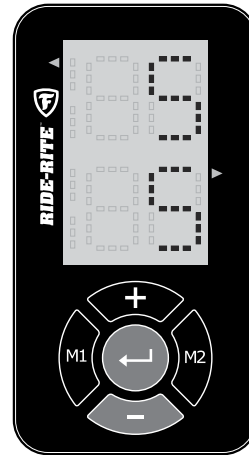

LEAK AT AIR LINE TUBE AND AIR FITTING

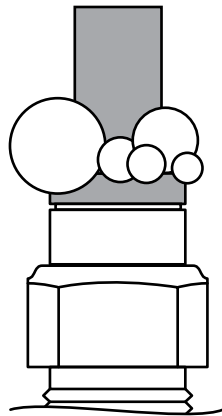

Release air line tube (see page 4).
Review proper cuts and procedures in Step 5.
Repeat Step 5.

LEAK AT BASE OF AIR FITTING

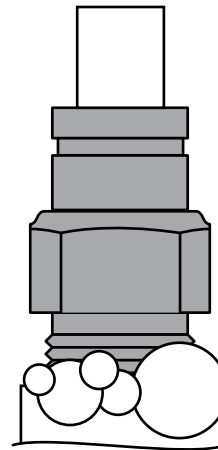

Tighten air fitting one turn or until leak stops.

STILL HAVE A LEAK?

Refer to the Troubleshooting section of the Instruction Manual. If the leak persists, or if there is an issue with a leaking part, call 1-800-888-0650; Option 1; Option 1 for Tech Support.



riderite.com

SAFELY RETURN VEHICLE TO OPERATIVE STATE

If you removed any wheels during installation, install the wheels and torque the lug nuts to the manufacturer's specifications. Safely remove any jack stands and wheel chocks used during installation. Re-attach the negative battery cable.

READ AND UNDERSTAND THE OPERATING INSTRUCTIONS

The Ride-Rite system can improve handling and comfort. Take the time to learn how to properly use and maintain your investment by reading the Operating Instructions.

BEFORE YOU DRIVE, CONFIRM THE FOLLOWING:

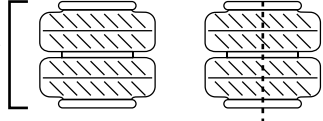
- Do you have a minimum of 5PSI in your air springs?
- Are your air springs standing 5 1/2" - 6 1/2" tall? 
- Are your air springs properly aligned, left-to-right and front-to-back?
- Are your nuts and bolts tight?
- Have you removed the threaded rods from Steps 1 and 2?
- Put your paper work back into the sleeve and keep it in your glove compartment for future reference.
- Secure all Air Line Tubes and wiring.
- The system passes the leak test and holds air.
- The Air Compressor ground ring terminal is contacting bare metal, and coated with silicone if possible.
- The Wire Harness is grounded to the negative (-) battery terminal. The ECU needs a good, clean, interference-free ground.
- There is a loop in the Air Line Tubes as shown to prevent water or debris from getting into the Air Compressor head and damaging it.
- You've been bagged...and now your suspension is Airide equipped! Show it off with the supplied decal!

NEED INSTALLATION HELP? 1-800-888-0650

Select Option 1 for Ride-Rite; Select Option 1 for Technical Support.

Or, email us at rrtech@fsip.com. Please include photos to help us better diagnose and understand any problems you may be experiencing.

Firestone
Firestone Industrial Products

CONNECT WITH US



FirestoneIP



Firestone Ride-Rite