

NOT LEGAL FOR SALE OR USE ON ANY POLLUTION-CONTROLLED MOTOR VEHICLE IN CALIFORNIA OR IN STATES THAT HAVE ADOPTED CALIFORNIA EMISSION PROCEDURES.

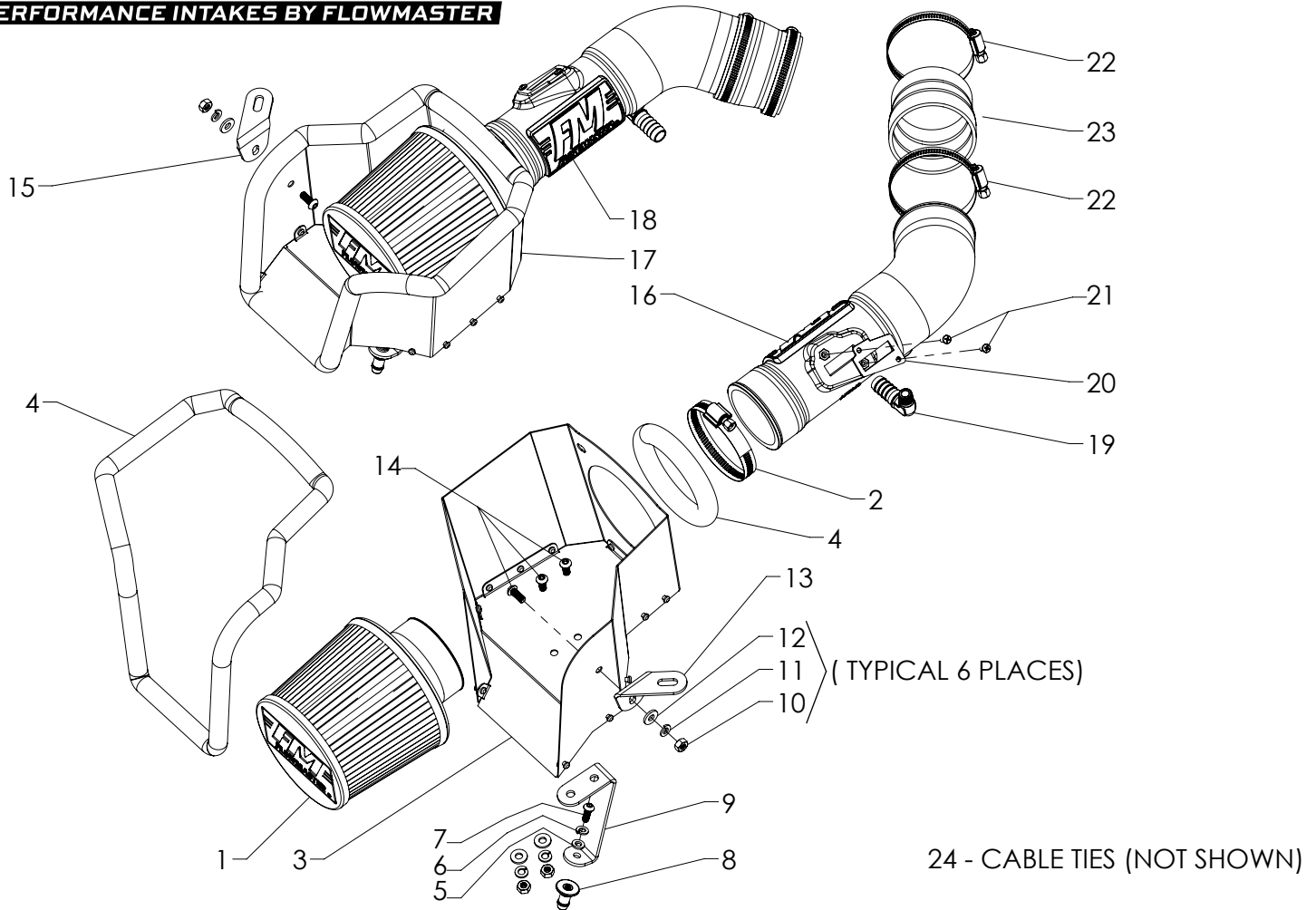

24 - CABLE TIES (NOT SHOWN)

ITEM NO.	PART NUMBER	DESCRIPTION	QTY.
1	AF1004	AIR FILTER, 6-7/8" × 2-3/4" DIA	2
2		CLAMP, SCREW, #44 (2-1/4" - 3-1/4")	2
3	AF3045	HEAT SHIELD, 09-18 NISSAN 370Z, 3.7L - LEFT	1
4	49000061	GASKET, HEAT SHIELD	108"
5	HW319	FLAT WASHER, M6	2
6	HW318	LOCK WASHER, M6	2
7	HW244	SCREW, M6 × 1.0 × 16MM	2
8	AF7001	BARBED PIN, M6 × 1.0	2
9	AF5048	LOWER BRACKET, 09-18 NISSAN 370Z, 3.7L	2
10	HW115	NUT, 1/4"-20	6
11	HW322	LOCK WASHER, 1/4"	6
12	HW320	FLAT WASHER, 1/4"	6

ITEM NO.	PART NUMBER	DESCRIPTION	QTY.
13	AF5049	LEFT BRACKET, 09-18 NISSAN 370Z, 3.7L	1
14	HW245	SCREW, 1/4"-20 × 5/8"	6
15	AF5050	RIGHT BRACKET, 09-18 NISSAN 370Z, 3.7L	1
16	AF2046	INTAKE TUBE, 09-18 NISSAN 370Z, 3.7L - LEFT	1
17	AF3046	HEAT SHIELD, 09-18 NISSAN 370Z, 3.7L - RIGHT	1
18	AF2045	INTAKE TUBE, 09-18 NISSAN 370Z, 3.7L - RIGHT	1
19	AF4038	ELBOW, 90°, 5/8" BARB TO 1/4" NPT MALE	2
20	GA139	GASKET, MAF SENSOR	2
21	HW248	SCREW, M4 × 0.7 × 12MM	4
22	MC250H	CLAMP, SCREW, #44 (2-1/4" - 3-1/4")	4
23	AF4063	COUPLER, REDUCING 3" - 2-3/4" I.D. × 2-1/2" L	2
24	HW535	CABLE TIE, 12" L × 0.298" W	4

REVIEW THE INSTRUCTIONS AND VERIFY THE KIT CONTENTS:

1. Take a moment to read and understand these instructions before installing your Flowmaster performance air intake kit.



2. Use the parts drawing and list (front page) to verify your kit's contents.

In the unlikely event that any parts are missing, contact FLOWMASTER Technical Support for replacements.

To simplify assembly and avoid cross-threading fasteners, identify and separate the 1/4-20 screws (item 14) (used with nuts (10)), and the M6 screws (7) (used with barbed pins (8)).

NOTE

Parts identified "right" go on the passenger side; those identified "left" go on the driver side.

REMOVE THE FACTORY AIR INTAKE SYSTEM:

NOTES

- We highly recommend that you retain all factory air intake system parts.
- Refer to your vehicle manufacturer's recommendations regarding removal of factory components.
- Disconnecting the negative battery cable erases pre-programmed electronic memories. Write down all memory settings before disconnecting the negative battery cable. Some radios will require an anti-theft code to be entered after the battery is reconnected. The anti-theft code is typically supplied with your owner's manual. In the event your vehicle's anti-theft code cannot be recovered, contact an authorized dealership to obtain your vehicle's anti-theft code.

3. Turn off the vehicle's ignition and disconnect the negative battery cable. **Failure to disconnect the battery may cause the CHECK ENGINE light to illuminate after the air intake kit is installed.**



4. Remove the two bolts and the front engine appearance cover.

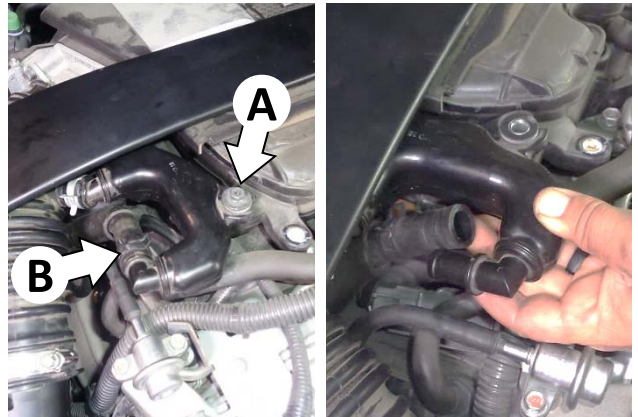

5. On the passenger side, remove the bolt (A) securing the plastic tube to the engine. Open the pinch clamp (B), separate the hose from the plastic tube, and remove and retain the pinch clamp for reuse.



6. On the driver side, open the pinch clamp, separate the hose from the plastic tube, and remove and retain the pinch clamp for reuse.

NOTE

Illustrations for Steps 7–11 shown the passenger side.

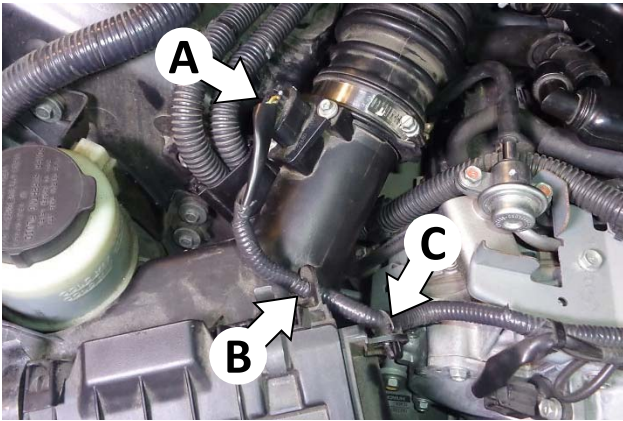

7. Disconnect the mass airflow (MAF) sensor plug (A), release the wire loom from the hook (B), and carefully separate the wire loom clamp (C) from the airbox. **NOTE: Use care when removing the clamp, as it will be reused at Step 37. REPEAT ON THE DRIVER SIDE.**



8. Loosen the screw clamp connecting the inlet air duct to the airbox, then separate the duct from the airbox. **REPEAT ON THE DRIVER SIDE.**

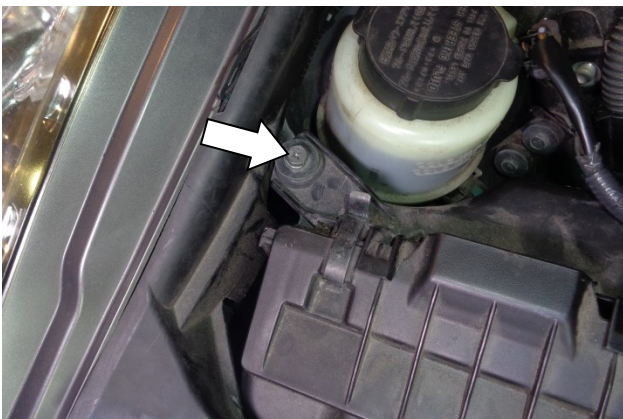

9. Remove the airbox mount bolt and retain for reuse. **REPEAT ON THE DRIVER SIDE.**



10. Remove the airbox from the vehicle by pulling it up sharply to release it from its mount grommets. **REPEAT ON THE DRIVER SIDE.**

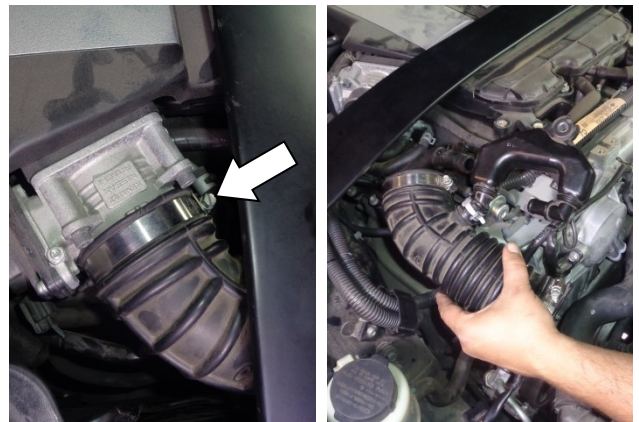

11. Loosen the screw clamp connecting the inlet air duct to the throttle body. Then separate the duct from the throttle body, and remove the duct and plastic tube from the vehicle. **REPEAT ON THE DRIVER SIDE.**

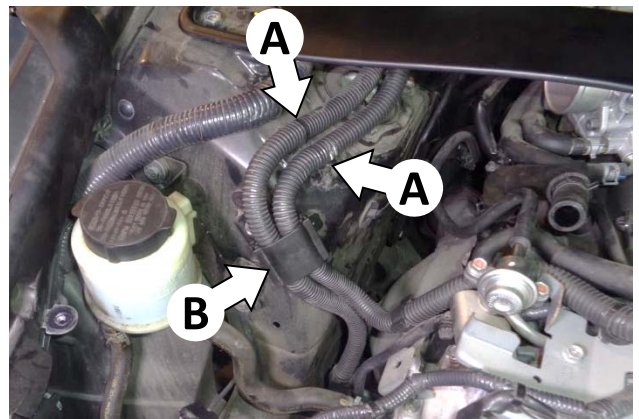

12. On the passenger side, carefully cut the two cable ties (A) securing the two smaller wire looms to the vehicle. **CAUTION: Do not cut the cable tie on the larger wire loom.** Then for the next step, note the large clamp (B) securing the two wire looms.

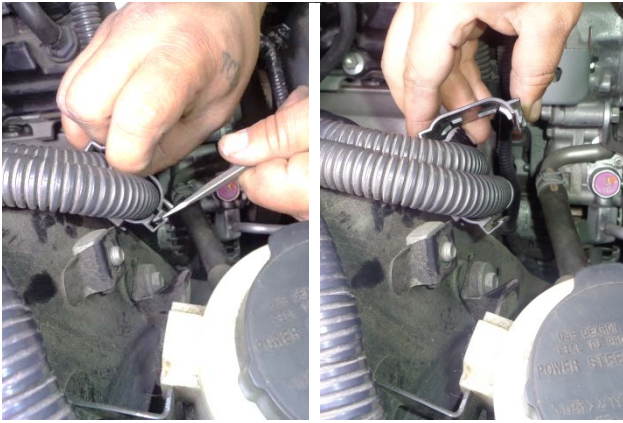

13. Use a flat-tip screwdriver to release the latch on the clamp. Open the clamp and remove the two wire looms from it.

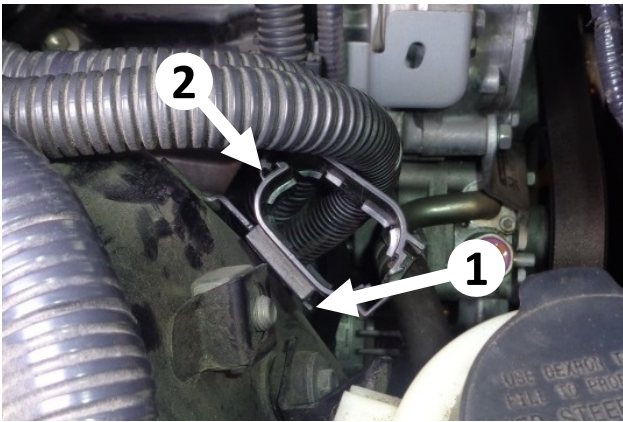

14. Use a flat-tip screwdriver to push the latch down, then slide the clamp off the metal tongue and remove it from the vehicle.



15. Remove the MAF sensor from each airbox, then remove the factory gasket from each sensor.
CAUTION: The sensors are delicate. Handle them with care, and put them in a safe place until reinstallation.

ASSEMBLE AND INSTALL YOUR FLOWMASTER PERFORMANCE AIR INTAKE SYSTEM:



16. Attach the gasket (4) to the both the I.D. and the outer edge of the right heat shield (17) as shown. Firmly press the gasket onto the edge, gradually working all the way around. When you return to the starting point, use metal-cutting shears to trim the gasket to fit. **REPEAT ON THE LEFT HEAT SHIELD (3).**



17. Attach right bracket (15) to the right heat shield as shown, using a ¼-20 screw (14) (against the heat shield) and a flat washer (12), lock washer (11), and nut (10) (against the bracket). **REPEAT WITH LEFT BRACKET (13) ON THE LEFT HEAT SHIELD.**



18. Attach a lower bracket (9) to each heat shield as shown, using ¼-20 screws (14) (against the heat shield) and flat washers (12), lock washers (11), and nuts (10) (against the bracket).



19. On each bracket, install a barbed pin (8), using an M6 screw (7), lock washer (6) and flat washer (5).



22. Slip the screw clamps (22) onto the reducing couplers (23), and install the large ends of the couplers on the discharge ends of the intake tubes. Do not tighten the clamps at this time.



20. Install a MAF sensor gasket (20) on each sensor, then install a sensor in each intake tube (18 and 16).
NOTE: Ensure the correct orientation of the gaskets and sensors to the mount pads (note the flat lobes). Secure each sensor using M4 screws (21).



23. **PASSENGER SIDE:** Temporarily slip the assembled intake tube and coupler onto the throttle body.



21. Apply 2 wraps of nylon thread tape to the threads of the barbed elbows (19), and install one in each intake tube.



24. Mark the breather hose in line with the end of the barbed section of the elbow. Then remove the intake duct, cut off the excess hose, and slip the pinch clamp onto the remaining hose.

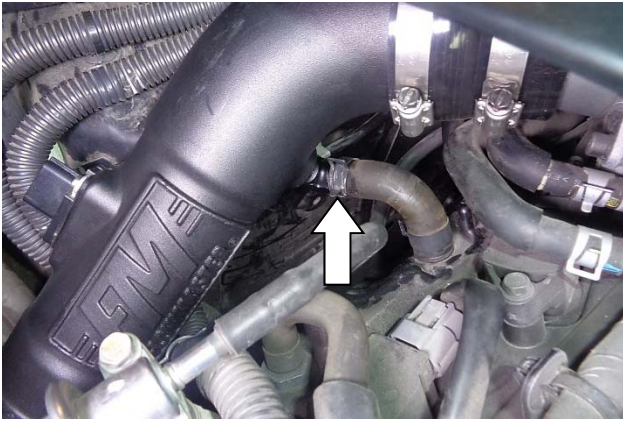

25. Push the hose onto the elbow, push the coupler onto the throttle body, and secure the hose to the elbow with the stock pinch clamp.

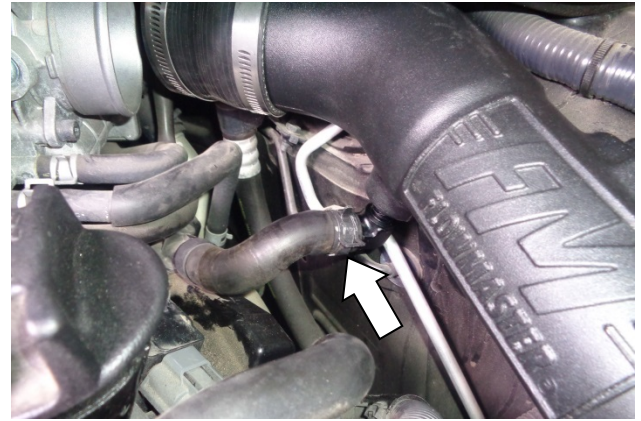

28. Remove the assembled tube and coupler from the throttle body. Then push the breather hose onto the elbow, push the coupler onto the throttle body, and secure it with the stock pinch clamp.



26. Push the coupler up against raised stops on throttle body. Snug (but do not fully tighten) the clamps at this time.



29. Push the coupler up against raised stops on throttle body. Snug (but do not fully tighten) the clamps at this time.



27. **DRIVER SIDE:** The breather hose should already be the correct length. Temporarily install the assembled intake tube and coupler onto the throttle body. Verify that the breather hose will fit all the way onto the elbow. (Cut off any excess hose, if necessary.)

NOTE

Illustrations for Steps 30–37 show the passenger side.



30. Remove the screw clamp (2) from the filter (1), and slip it over the intake tube. **REPEAT ON THE DRIVER SIDE.**



31. Carefully push the air filter flange through the heat shield opening. **REPEAT ON THE DRIVER SIDE.**

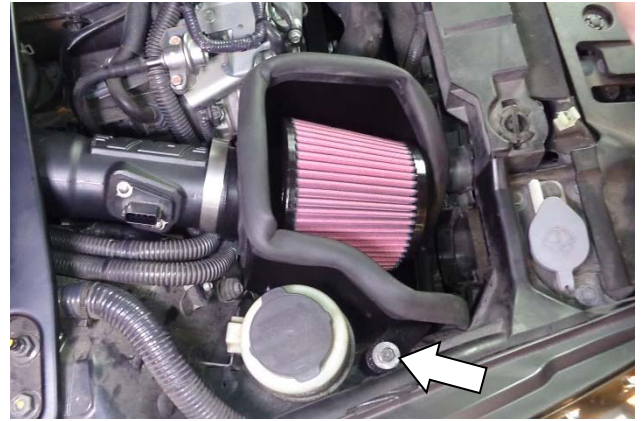

34. Secure the heat shield to the vehicle using the stock airbox mount bolt. **REPEAT ON THE DRIVER SIDE.**

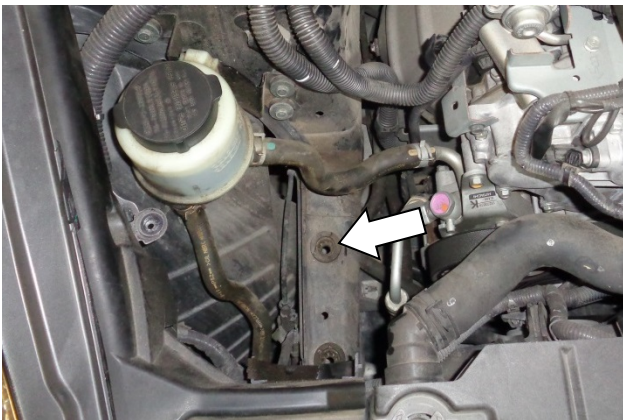

32. Before installing the heat shields, note that their barbed mount pins will be inserted in the rear mount grommets. (Moistening the grommets with soapy water will ease insertion.)



35. Adjust the alignment / rotation of the intake tube as required to obtain the best engagement with the coupler and the filter. Then secure the filter to the intake tube with the screw clamp. **REPEAT ON THE DRIVER SIDE.**

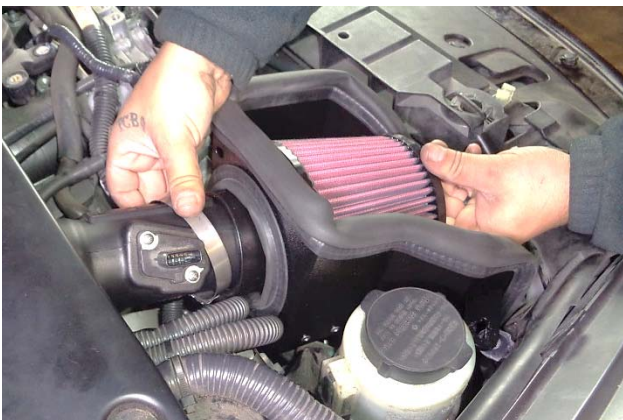

33. While holding the filter inside the heat shield, push the filter onto the intake tube, and press the heat shield's mount pin into the grommet in the vehicle frame. **REPEAT ON THE DRIVER SIDE.**



36. Tighten the screw clamps on the coupler. **REPEAT ON THE DRIVER SIDE.**

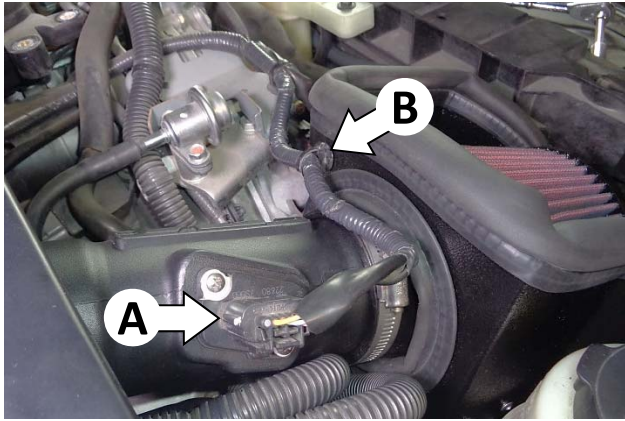

37. Connect the MAF sensor plug (A) to the sensor, and check the plug for security. Then press the wire loom clamp (B) into the hole in the heat shield. **REPEAT ON THE DRIVER SIDE.**

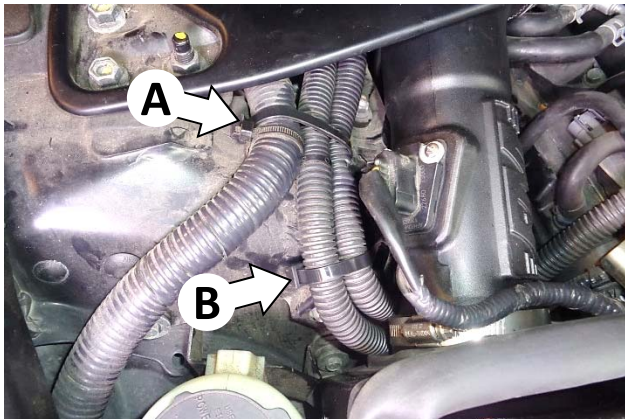

38. Use cable ties (24) to secure the two small wire looms to the large wire loom at (A), and to secure the two small wire looms to each other at (B).



39. Install the front engine appearance cover and 2 bolts.



Congratulations, the installation of your FLOWMASTER performance air intake kit is now complete!

FILTER MAINTENANCE:

We recommend that you clean and oil your air filter at 25,000 mile intervals using **Flowmaster's Filter Refresh Kit (PN 615001)**. See our website or your Flowmaster distributor for details.

IMPORTANT: RETAIN THESE INSTRUCTIONS FOR FUTURE REFERENCE

Flowmaster maintains a highly-trained technical service department to answer your technical questions, provide additional product information and offer various recommendations.

Direct all correspondence and warranty questions to:

Flowmaster

100 Stony Point Rd., Suite 125
Santa Rosa, CA 95401

Flowmaster Technical Service: (707) 544-4761
Monday – Friday: 7:30 am to 5:00 pm Pacific Time
(Closed Saturday and Sunday)

