**READ ME !** 

Thank you for purchasing a Front Runner 140mm Cargo Rail.

Before you start, take a moment to familiarize yourself with the Fitting Instructions and the components received.

Refer to Page 2 for a list of all the components, quantities and tools required.

IMPORTANT WARNING! 

IT IS CRITICAL THAT ALL FRONT RUNNER PRODUCTS BE PROPERLY AND SECURELY ASSEMBLED AND ATTACHED TO YOUR VEHICLE. IMPROPER ATTACHMENT COULD RESULT IN AN AUTOMOBILE ACCIDENT, AND COULD CAUSE SERIOUS BODILY INJURY OR DEATH. YOU ARE RESPONSIBLE FOR ASSEMBLING AND SECURING ALL FRONT RUNNER PRODUCTS TO YOUR VEHICLE, CHECKING THE ATTACHMENTS PRIOR TO USE, AND PERIODICALLY INSPECTING THE PRODUCTS FOR ADJUSTMENT, WEAR AND DAMAGE. THEREFORE, YOU MUST READ AND UNDERSTAND ALL OF THE INSTRUCTIONS AND PRECAUTIONS SUPPLIED WITH YOUR FRONT RUNNER PRODUCT PRIOR TO INSTALLATION OR USE. IF YOU DO NOT UNDERSTAND ALL OF THE INSTRUCTIONS AND CAUTIONS, OR IF YOU HAVE NO MECHANICAL EXPERIENCE AND ARE NOT THOROUGHLY FAMILIAR WITH THE INSTALLATION PROCEDURES, YOU SHOULD HAVE THE PRODUCT INSTALLED BY A PROFESSIONAL INSTALLER OR OTHER QUALIFIED PERSONNEL.

NOTE: Front Runner will not be responsible for any damage caused by the failure to install the product according to these instructions.

Please call us if you have any questions about the installation of this product.

1

GET ORGANIZED

IN THE BOX

1	1 X	Track 140mm Long
2	2 X	Track End Cap
3	1 X	M8 T-Bolt
4	1 X	M8 x 25 x 2 Flat Washer
5	1 X	M8 Eye Nut

FIGURE 1.1

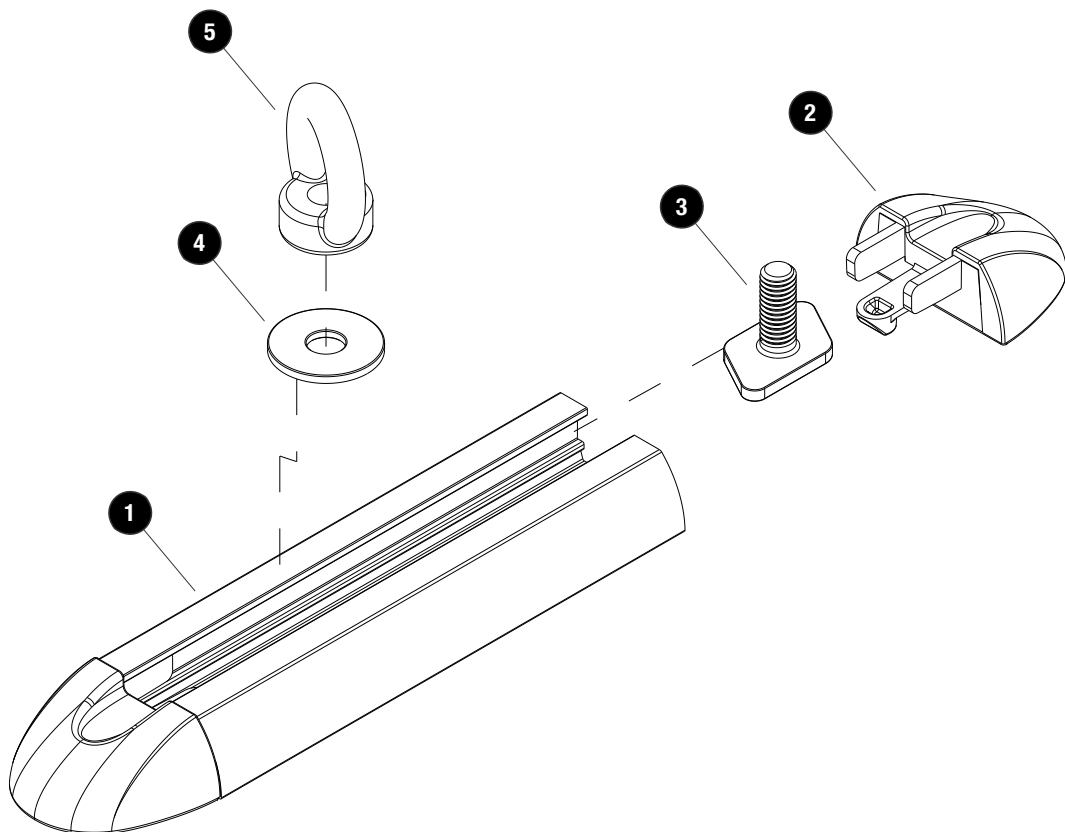

2**FIT AND SECURE**

2.1

Decide on a suitable position for your Tie Down Rail to be mounted. Take some time to consider the best suited method of securing the Rail and what fasteners and tools will be required to complete the job. It is advised that M6 Button Head Bolts are used and that the Rail is secured in a minimum of two places.

2.2

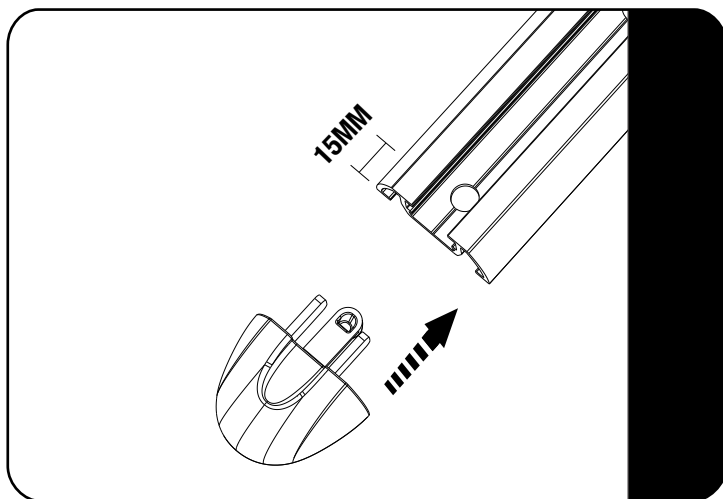

Should you wish to fit the End Caps to the Rail, you will need to drill a 8.5 mm Hole 15mm in from each end as shown. Only fit the End Caps once the Tie Down Rail has been fitted to the vehicle and the Channel Nut has been inserted. (Refer to Step C).

The Caps are fitted by pushing the Caps into the Rail and clipping them into position as shown.

2.3

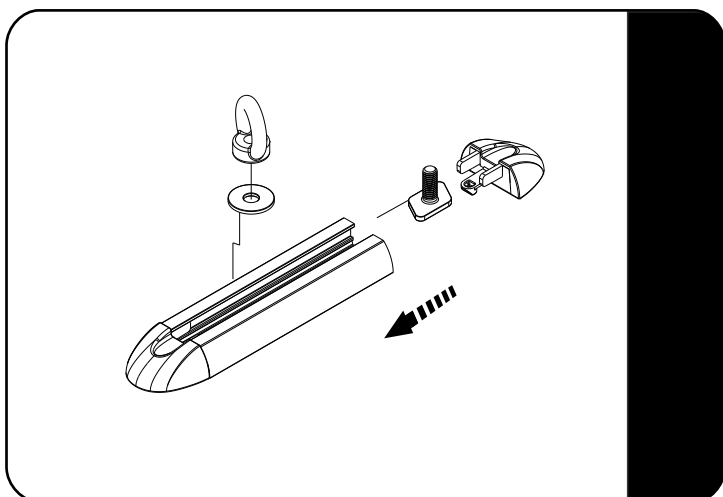

Once the Rail has been secured in position, slide the T-Bolt into the Tie Down Rail. Fasten the Eye Nut and shown.

3

FINISH

Congratulations! You did it. Take a step back and admire your work!

4

INSTALL OTHER VEHICLE AND RACK ACCESSORIES

Now's the time to visit your favorite Front Runner Dealer in person or online.

Be sure to tag us. We love to see our gear in action! #FrontRunnerOutfitters #BornToRoam

Share your adventures on: 