

# INSTRUCTION MANUAL

## CAT-BACK STAINLESS SINGLE EXHAUST

Dodge Dakota Truck 3.7L-4.7L  
 Quad Cab, Short Bed 2/4wd, Club Cab, Short Bed 2wd  
 Mitsubishi Raider 3.7L- 4.7L  
 Extended & Double Cab, Short Bed 2wd

### PART # 616599B

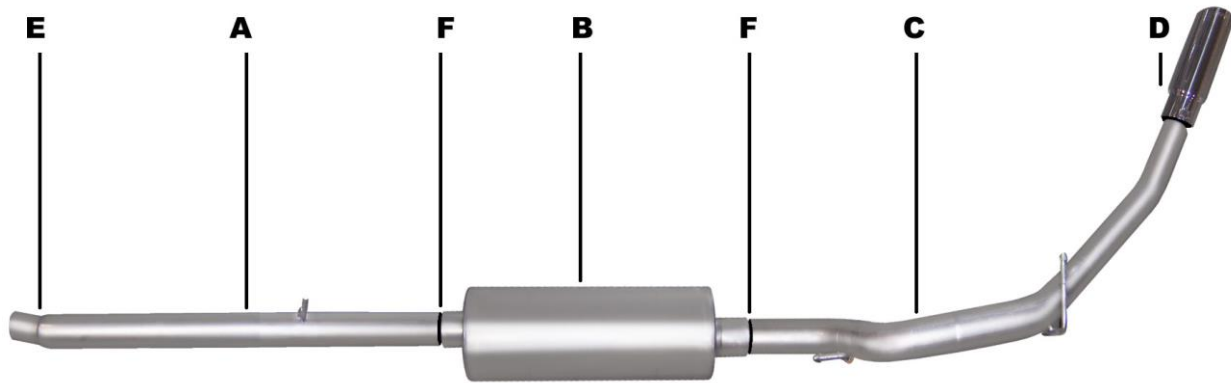

Item	Part #	Quantity	Description
A	938-700713S	1	3.00" Stainless Headpipe
B	421887	1	SuperFlow Stainless muffler
C	939-700716S	1	3.00" Stainless Tailpipe
D	500360-B	1	Black Ceramic Tip
E	5757	1	2.50" Clamp
F	OHD300	2	3.00" Clamp(s)

Thank you for purchasing our GIBSON EXHAUST SYSTEM for your vehicle. If you need further assistance, please do not hesitate to call our Technical Department at 1-800-528-3044, Monday through Friday, 8:00 am to 5:00 PM

# EXHAUST INSTALLATION #616599B

When installing this exhaust system make sure to use proper safety precautions. Use jack stands when under the truck, set parking brake, block tires and use safety glasses and gloves.

**DO NOT WORK WITH HOT PIPES!**

## SUGGESTED TOOLS:

1/2" , 9/16", 15mm Socket & Wrench, WD-40, Jack Stand, Sawzaw



Lay out the exhaust on the floor so it looks like the drawing and compare parts with manual. To remove the stock exhaust un-bolt it from the tailpipe and then remove it, next un-bolt the clamp that is located after the Y-pipe. Leave all rubber grommets in place. Use WD-40 to aid in removal of exhaust and the hangers.



Install the over axle tailpipe # C into the muffler 1-1/2" to 2". Secure to the muffler using clamp # F Do not tighten.



Install head pipe # A on to your existing stock front pipe and secure with clamp # E Use a jack stand to support the converter. Insert welded hanger into rubber grommet. Do not tighten.



Install stainless steel tip. Clamp down. When you have everything in place, firmly tighten all bolts and clamps down securely. To clean stainless steel tip use any stainless steel cleaner.



Install muffler #B onto head pipe # 1-1/2" to 2" with the louvers facing towards the converter. Use a jack stand to support the muffler. Use clamp #F to secure the muffler to the head pipe. Do not tighten. Muffler inlet is looking into the louvers.

**MAKE SURE YOU HAVE A 1" CLEARANCE ON ALL RUBBER BRAKE LINES, SHOCK BOOTS, TIRES, FUEL LINES, ETC..**