

Marker Light and Wiring Components

- | | | | | | | | |
|----|---------------|-----|-------------------------|-----|-----------------------------|----|-------------------------|
| 1. | | 2. | | 3. | | 4. | |
| | Marker Light | | Butt Connector | | Posi-Tap Connector | | Marker Light Lens Cover |
| 5. | | 6. | | 7. | | 8. | |
| | Blackout Film | | Marker Light Gasket | | Washer | | Screw |
| 9. | | 10. | | 11. | | | |
| | Wire Stay | | Connection Wire (30 ft) | | R98022
ALCOHOL PREP PAD, | | |

Components and Hardware:

- | | | |
|-----|------------------------------|----------|
| 1. | Marker Light..... | (4) |
| 2. | Butt Connector..... | (8) |
| 3. | Posi-Tap Connector..... | (8) |
| 4. | Marker Light Lens Cover..... | (5) |
| 5. | Blackout Film..... | (4) |
| 6. | Gasket..... | (4) |
| 7. | Washer..... | (8) |
| 8. | Screw..... | (8) |
| 9. | Wire Stay..... | (8) |
| 10. | Connection Wire..... | (30 ft.) |
| 11. | Alcohol Prep Pad..... | (2) |

Tools for Installation:

- Utility Knife
- #2 Phillips Screwdriver
- Wire Crimp Tool

Fender Flare Components and Hardware:



1. SW1-0036,
M6-.3 x 20mm Hex
Magni Black Screw,



2. SW1-0058,
#10 x 5/8" Phillips
SS Truss Screw,



3. CL1-0009,
Long "U" Clip,
Magni 565



4. MT1-0034,
1" x 1.5" x .06"
Blk 3M Foam Tab,



5. GP1-0025,
EX4008 Wiper
Style Edge Trim,

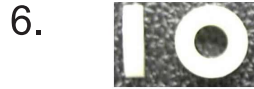

6. SP1-0002,
1/2" x .260" x 1/8"
Nylon Spacer,



7. ET1-0002,
Edge Trim Tool,



8. Front Fender Flare



9. Rear Fender Flare

Components and Hardware:

1. M6-.3 x 20mm Hex Magni Black Screw.....	(32)
2. #10 x 5/8" Phillips SS Truss Screw.....	(4)
3. Long "U" Clip	(4)
4. Blk 3M Foam Tab.....	(4)
5. Wiper Style Edge Trim.....	(389")
6. 1/2" x .260" x 1/8" Nylon Spacer.....	(20)
7. Edge Trim Tool.....	(1)
8. Front Fender Flare (LH & RH).....	(2)
9. Rear Fender Flare (LH & RH).....	(2)

Tools for Installation:

- Utility Knife
- #2 Phillips Screwdriver
- Socket Wrench
- 10mm Socket
- Awl or Similar Pointed Tool
- Grease Pencil
- Pliers

Toyota Fender Flares

PRIOR TO INSTALLATION

1

- A. Husky® only approves installing the flares according to these written instructions with the hardware provided. **WARNING:** Failure to install according to these instructions will invalidate the warranty. This includes, but is not limited to using alternative installation methods, hardware, or materials. **DO NOT USE:** Loctite, SuperGlue, or similar products on the hardware or the flares.
- B. **Fit:** Verify the fit of the flares to vehicle. (Some filing, sanding, or cutting may be necessary to ensure proper fit).
- C. **Painting:** (Optional) if paint is desired it must be done prior to installing flares on vehicle. Clean outer surface with a good grade degreaser. **DO NOT USE LACQUER THINNER OR ENAMEL REDUCER AS A DEGREASER.** Wipe outer surface thoroughly with a tack rag prior to paint. Application of plastic adhesion promoter for ABS plastic as per your paint system manufacturer's recommendations is required. Paint flares using a high quality enamel, or polyurethane automotive paint. If painting edge trim (not recommended), use a flex additive.
- D. **Performance:** Using larger Tires may increase the area required to turn the vehicle. Some Tire/Rim combinations may require lowering bump stops and or installing steering stops to prevent tire from contacting flare.
- E. **Exhaust System:** Modifications may be necessary to maintain a minimum 4" clearance between flares and exhaust pipes. (Exhaust gases should not vent directly onto flares)
- F. **Metal Protection:** All exposed fasteners and bare metal should be treated with rust resistant paint **BEFORE** installing flares. Spray inner fender wells with undercoating **AFTER** flare attachments have been completed.
- G. **Decals:** Flares may interfere with existing decals on vehicle. If you wish, remove decals prior to installation of flares.
- H. **Care & Cleaning:** Husky® fender flares are built to last; any detergent you use to wash your vehicle is sufficient to clean the flare. Do not use any harsh abrasive detergents.

PLEASE READ: Dirt and debris can become lodged between the fender flares and the vehicle's fenders, causing scratching and paint wear from vibration. Husky® is not responsible for any damage, and the installation of our fender flares is done with the buyer's understanding that this scratching and paint wear may occur.

3 YEAR LIMITED WARRANTY AGAINST ANY MANUFACTURING DEFECTS

- To claim a warranty, you must provide Proof of Purchase.

Toyota Fender Flares

Light Assembly Installation

2

- A) Clean the top surface of the cover (indicated by blue arrow) with the alcohol pad.
- B) Install the Blackout Film to the top surface Cover by first aligning the two dashed red edges as shown.
- C) Assemble Light assembly to fender flare as shown. Route marker light wire through the center hole in the gasket and fender flare. **DO NOT** overtighten screws as this could crack the cover. Tighten enough that the light assembly does not move.

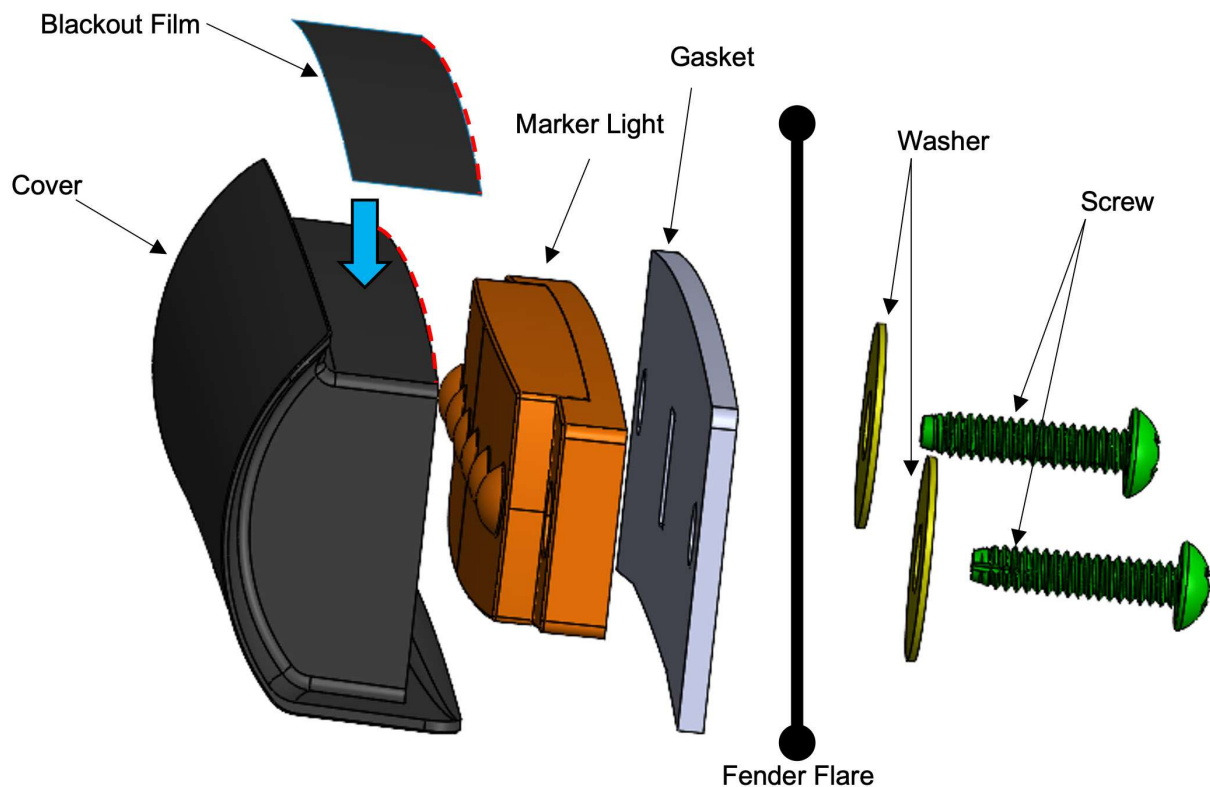

Toyota Fender Flares

Edge Trim Installation

3

- A) Peel two to three inches of red vinyl backing away from Edge Trim tape. Applying the adhesive side of the edge trim to the inner side of the flare, affix the edge trim to the top edge of the flare (the portion that comes in contact with the vehicle).
- B) Press edge trim into place along the top edge of the flare in one-foot increments, pulling red vinyl backing free as you continue to work your way around the top edge of the flare.



Marker Light Wiring Detail

4

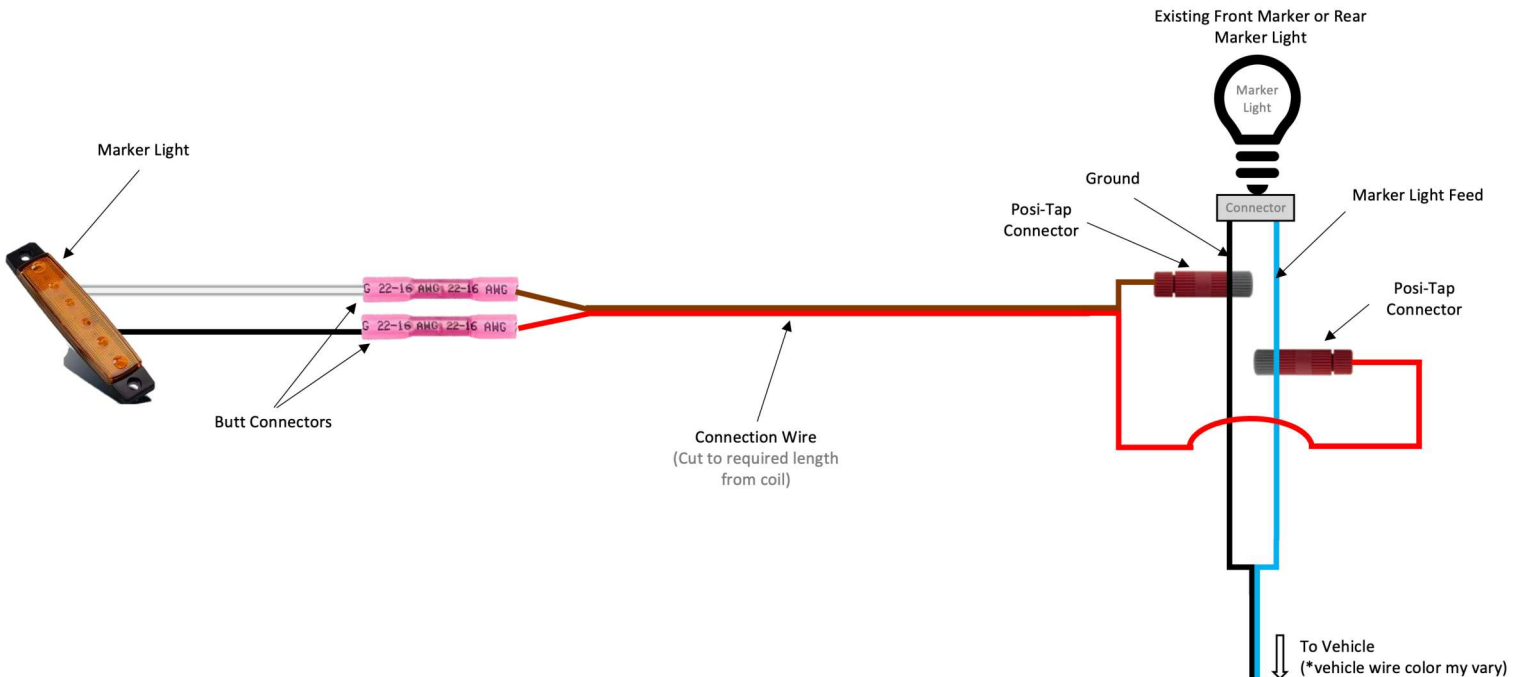

Toyota Fender Flares

Front Flare Installation Procedures (Passenger's Side):

5

*Reference Step 4 Image

- A) Find and access the wiring harness for your front or rear marker light. *Note that the marker light is often integrated into the headlight and taillight assemblies.
- B) Using two Posi-Tap connectors and the connection wire, connect the red lead to the marker light feed and the brown lead to a ground.
- C) Route the connection wire to the top center of the fender area. Use Wire Stays as appropriate to help manage wires.
- D) Cut the connection wire, leaving 1 foot of extra wire extended down from the top center of the fender area.
- E) Repeat Steps A-D at the other three flare locations.



6

Using a 10mm socket, remove nine factory fasteners from wheel well.

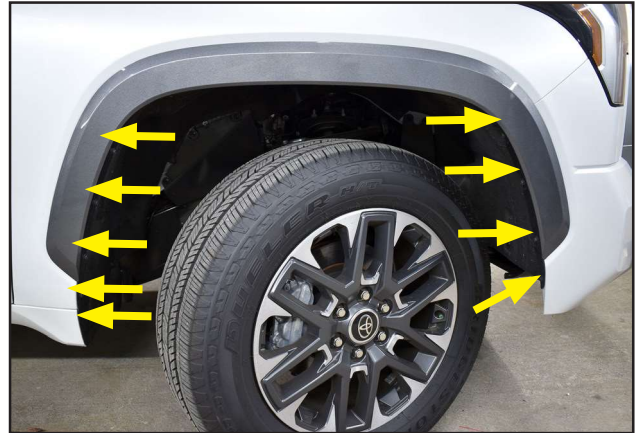

7

Hold flare in position on the wheel well and mark the two top hole locations using a grease pencil. Remove flare and set aside.



Toyota Fender Flares

8

Wrap a Foam Tab (MT1-0034) around the wheel well sheet metal, centered over each of the upper two marks made in **Step 7**.



9

Install a Clip (CL1-0009) over each of the two Tabs (MT1-0034).

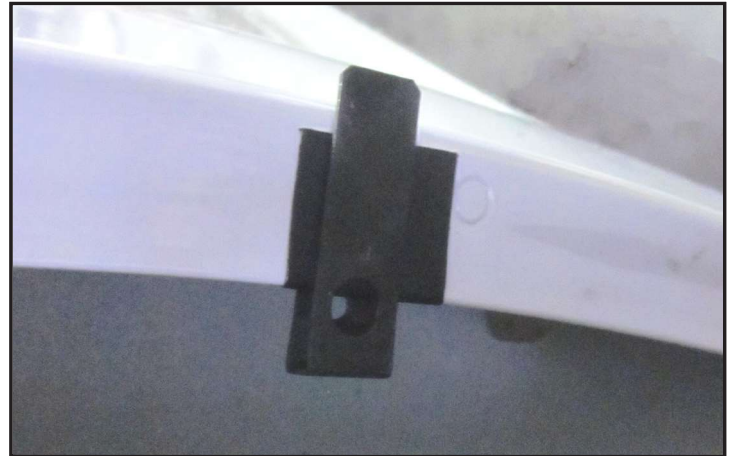

10

A) Before final install of the flare, connect the marker light to the connection wire using two Butt Connectors. Connect black to red and white to brown. Reference Step 4 image.

B) Properly heat shrink the connection.



Toyota Fender Flares

11 Hold the flare firmly in place on the fender. Install flare using nine supplied 20mm hex screws (SW1-0036).

*SR models will need spacer installed. See Frame 12.



12 *For SR models only, use spacer (SP1-0002) in addition to hex screw (SW1-0036).

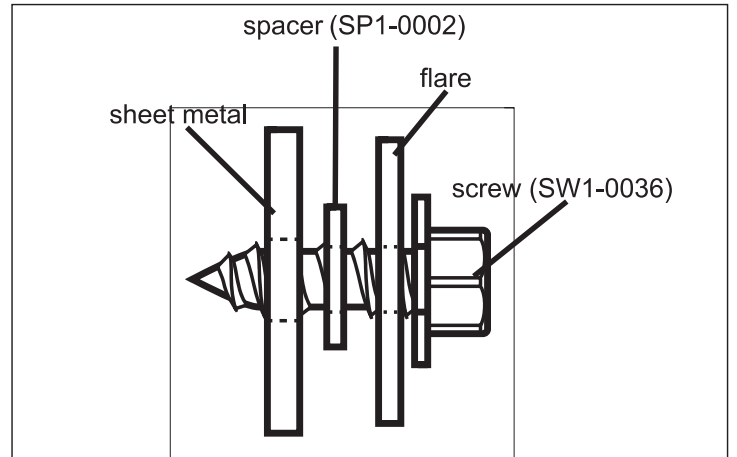

13 Install two supplied truss screws (SW1-0058) in the remaining two holes. Installation complete.



Toyota Fender Flares

14

Tuck the exposed wiring up between the lower flange of the flare and the fender so that no wiring is exposed. Use Wire Stays as appropriate to help manage wires.

Completed front flare installation.



15

Rear Flare Installation Procedures (Passenger's Side)

Remove five factory fasteners.
See details in Frames 12-14.



16

Remove two screws at rear of wheel well.



Toyota Fender Flares

23

Remove two screws at the top of wheel well.



24

Remove one screw at front of wheel well.



25

A) Before final install of the flare, connect the marker light to the connection wire using two Butt Connectors. Connect black to red and white to brown. Reference Step 4 image.

B) Properly heat shrink the connection.



Toyota Fender Flares

26

Hold the flare firmly in place on the fender. Install flare using seven supplied 20mm hex screws (SW1-0036). Installation complete.

*SR models will need spacer installed. See Frame 16.

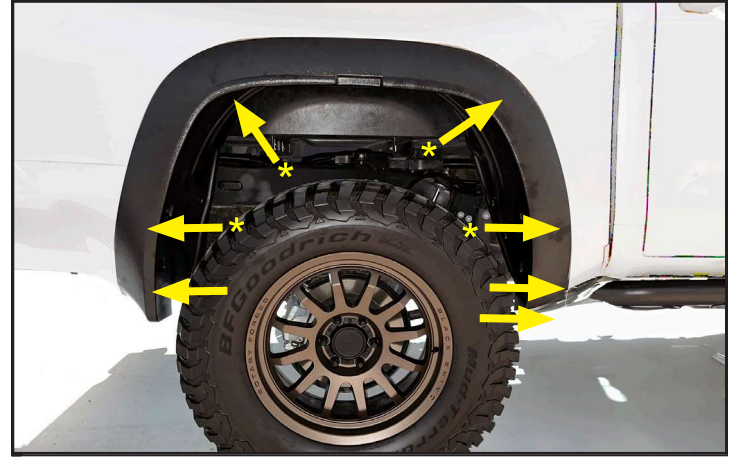

27

*For SR models only, use spacer (SP1-0002) in addition to hex screw (SW1-0036).

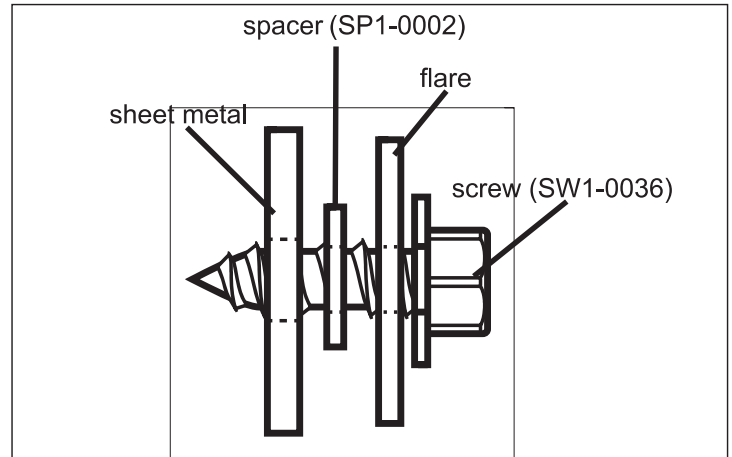

28

Tuck the exposed wiring up between the lower flange of the flare and the fender so that no wiring is exposed. Use Wire Stays as appropriate to help manage wires.

Completed rear flare installation.



Toyota Fender Flares

34

Using supplied Edge Trim Tool, seat edge trim against vehicle by hooking curved end under edge trim at one end of flare. Next, slide around outer edge of flare to the other end.



35

Using flat end of supplied Edge Trim Tool, seat edge trim against flare by inserting straight end between edge trim and flare at one end. Next, slide around entire edge to the other end.



Care and Cleaning

- Wash only with mild soap & dry with a clean cloth.



The material that your product is made from can be recycled. Please also consider recycling the packaging that your product came in.

Congratulations!

We take the utmost pride in our products and want you to enjoy years of satisfaction from your investment. We have made every effort to ensure that your product is top quality in terms of fit, durability, finish and ease of installation.

www.huskyliners.com

Phone: 800-344-8759

Email: customerservice@huskyliners.com

