



FSD23-734

Install Guide

Revision: B



© Kleinn Automotive Accessories 2019, All rights reserved.

PO Box 91278 Tucson, AZ 85752

Phone: (520) 579-1531

Web: www.Kleinn.com

Table of Contents

1.	Application Chart.....	4
1.1.	List of compatible vehicles	4
1.2.	Incompatible Vehicle Features & Trim Packages	4
1.3.	Aftermarket Product Compatibility	4
2.	Before You Start	5
3.	Installation Overview	5
3.1.	Kit Layout & Location.....	5
4.	List of Tools & Supplies.....	6
4.1.	Required Tools.....	6
4.2.	Specialty Tools	6
4.3.	Consumables	6
5.	Parts List	7
5.1.	Primary Kit Components.....	7
5.2.	Fittings & Related Items	7
5.3.	Electrical Components & Related Items.....	8
5.4.	Mounting Brackets	9
5.5.	Hardware & Related Items	10
6.	Recommended Routing of Air Tubing & Wire.....	11
7.	Bench Assembly	12
7.1.	Air Horns – Disassembly & Preparation	12
7.2.	Air Horns – Drivers-to-Bracket Installation	13
7.3.	Compressor – Setup & Installation.....	15
7.4.	Air Tank – Fittings & Air Tubing Installation	15
8.	On-Vehicle Assembly.....	18
8.1.	Horn Brackets – Passenger & Driver Side.....	18
8.2.	Horn Brackets – Main Bracket.....	20
8.3.	Air Tank Installation – Passenger Side Nut Plates	22
8.4.	Air Tank Installation – Driver Side Nut Plate	23
8.5.	Air Tank Installation – Air Tank Bracket Installation.....	24



Install Guide

FSD23-734

- 8.6. Air Compressor & Bracket Installation 28
- 8.7. Final Connections & Installation..... 29
- 9. On-Vehicle Electrical Installation 31
 - 9.1. Attach Relay & Fuse to Vehicle..... 31
 - 9.2. Install Horn Button 31
 - 9.3. Route Wiring & Make Connections 32
- 10. Testing the Air System 33
 - 10.1. Air Compressor Test 33
 - 10.2. Air Horn Test..... 33
 - 10.3. Quick Connect Coupler Test 33
- 11. Maintenance..... 34
- 12. Warranty Information..... 35



1. Application Chart

This kit is a direct bolt-on aftermarket product. The vehicles listed in the below table are considered to be compatible with this aftermarket kit. Every effort has been made to verify fitment on these vehicles in their factory condition.

NOTE: Before unpacking your kit, review this manual in full & verify the correct space & mounting locations exist with your trim package.

1.1. List of compatible vehicles

Year	Make	Model	Drivetrain	Engine	Cab	Bed	Trim
2023	Ford	F250 F350	TorqShift-G Ten-Speed Auto w/ Selectable Drive Modes	6.8L 2V DEVCT NA PFI V8 Gas	Regular Cab SuperCab Crew Cab	6-3/4' 8'	XL XLT LARIAT KING RANCH PLATINUM LIMITED
				7.3L 2V DECVT NA PFI V8 Gas			
2024	Ford	F250 F350		6.7L 4V OHV Power Stroke V8 Turbo Diesel			
				6.7L High Output Power Stroke V8 Turbo Diesel			

NOTE: Drilling holes may be required for installing ground wires and switches based on installers preference.

1.2. Incompatible Vehicle Features & Trim Packages

This kit may not be compatible with the following vehicle features / trim packages:

- All OEM chassis cab frames with service boxes or flat beds, as purchased from dealerships.
- Snow Plow Package
- Power Take-off

1.3. Aftermarket Product Compatibility

This kit has been designed to be compatible with the following products from leading manufacturers:

- Amp Research Power Steps

This kit has not been designed to be compatible with the following products:

- Front bumpers
- Winches

2. Before You Start

Read this manual in its entirety before starting installation. Verify you have all the parts listed & that you clearly understand the installation procedure. Contact KLEINN Technical Support with any questions you may have.

Installation of this kit requires moderate mechanical aptitude.

Use the proper tools, supplementary lighting, and safety equipment when installing this kit.

3. Installation Overview

3.1. Kit Layout & Location

Item No.	Description	Mounting Location	Approx. Install Time
1	6450RC Air Compressor	Inside passenger frame rail, above spare tire	2 Hours
2	6351RT Air Tank	Under rear bed floor, behind rear axle	4 Hours
3	730 Air Horns	Attached to frame rails, behind front bumper	2 Hours
4	1302 Relocation Kit	To be determined by Installer/Customer	N/A

Note: Wiring time is not factored into the overall install of this kit.

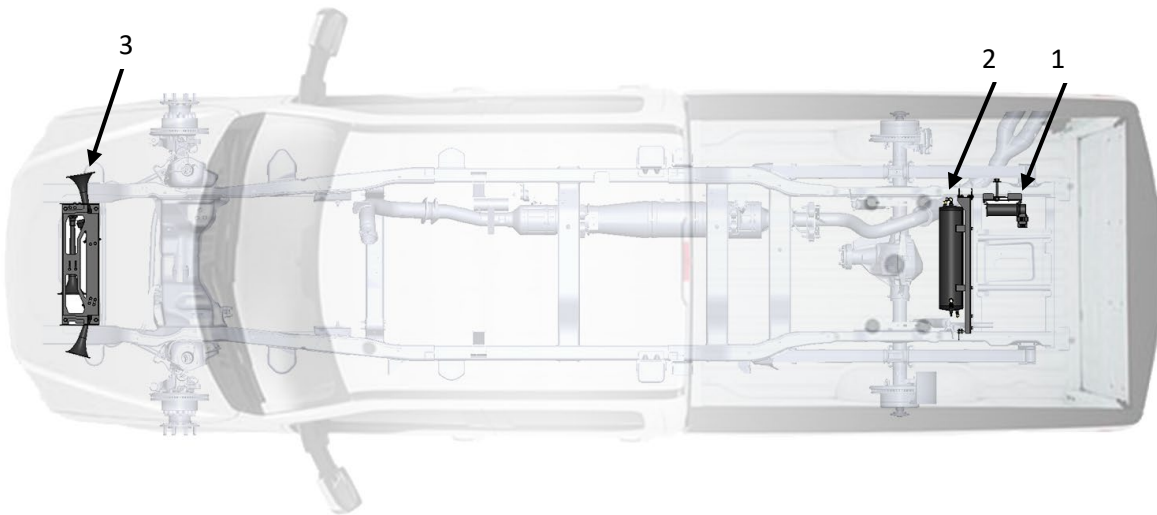

Figure 1- Kit Layout

4. List of Tools & Supplies

4.1. Required Tools

- Mechanic's 1/4" & 3/8" Drive & Socket Set – Imperial & Metric
- Combination wrenches – Imperial & Metric
- Hex wrenches – Imperial & Metric
- Screwdriver Set – #1, #2
- Wire Cutters
- Wire Strippers
- Wire Crimpers
- Utility Knife or Equivalent

4.2. Specialty Tools

- 1/4" & 3/8" Universal Joints
- 1/4" & 3/8" Extensions
- Multimeter, Test Light, or Equivalent
- Heat Gun
- Trim Panel Removal Tools
- Drill Driver & Bits
- Impact Driver & Bits
- Magnetic Retrieval Tools

4.3. Consumables

- Quality Electrical Tape
- Medium Strength Thread Locker
- Sand Paper, Wire Brushes or Equivalent
- Extra Zip Ties
- Touch-up Paint
- PTFE Thread Tape

5. Parts List



Unpackage & organize the kit contents and verify all parts listed below are included. Contact KLEINN Support if any questions arise.

5.1. Primary Kit Components

NOTE: Items in this section may come in their own packages which may include additional items, hardware, or documentation.



Item No.	Qty	Part No.	Description	Picture
1.	1	6450RC	200 PSI Waterproof Air Compressor Kit	
2.	1	6351RT	3 Gal. Air Tank, Slim Design, 6-Port	
3.	1	730	730 Series Air Horn Kit	
4.	1	1302	Quick Disconnect Air Relocation Kit <i>NOTE: May be located within INF-1 Kit</i>	
5.	1	INF-1	Tire Inflator Kit	

5.2. Fittings & Related Items







Item No.	Qty	Part No.	Description	Picture
F1.	1	51414	¼" NPT Male to Compression Fitting <i>NOTE: Fitting is part of the 1302 Kit (See 5.1)</i>	
F2.	1	52835	¼" NPT Male Drain Plug	

F3.	1	52175	175 PSI Pop-Off Safety Valve	
F4.	2	51414NPTL	¼" NPT Male to ¼" NPT Female, Elbow	
F5.	1	51238L	3/8" NPT Male to ½" Compression Fitting	
F6.	1	2151	Pressure Switch, 110 PSI On – 145 PSI Off	
F7.	26 ft	25012	½" Air Tubing	
F8.	2	JUICE	Kleinn Liquid Thread Sealant	
F9.	12 ft	25014	¼" Air Tubing NOTE: Tubing is part of the 1302 Kit (See 5.1) which is located within the INF-1 Bag	

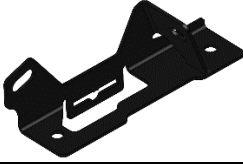
5.3. Electrical Components & Related Items



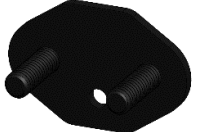
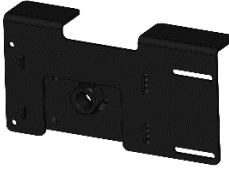









Item No.	Qty	Part No.	Description	Picture
-	1	320	Momentary Switch, NO	
-	1	6858	Wire Kit	
-	33 ft	N/A	1/4" Loom Pack	
-	33 ft	N/A	1/8" Loom Pack	
-	3 ft	N/A	3/8" Loom Pack	

5.4. Mounting Brackets

Item No.	Qty	Part No.	Description	Picture
-	1	-	Horn Mounting Bracket, Driver Side	
-	1	-	Horn Mounting Bracket, Passenger Side	
-	1	-	Horn Mounting Plate	
-	1	-	Air Tank Bracket, Passenger Side	
-	1	-	Air Tank Bracket, Driver Side	
-	3	-	Nut Plate	
-	1	-	Compressor Bracket	
-	2	-	Rectangular Washer	

5.5. Hardware & Related Items

Print out the hardware sheets at the end of this section at 100% Scale to facilitate hardware identification.

Item No.	Qty	Hardware Size	Description	Picture
H1.	6	5/16"-18, 125" Length	Hex Head Bolt	
H2.	12	5/16"-18	Hex Nut	
H3.	18	5/16"	SAE Flat Washer	
H4.	12	5/16"	Split-Lock Washer	
H5.	10	7/16"-14, 1.25" Length	Hex Head Bolt	
H6.	10	7/16"-14	Hex Nut	
H7.	20	7/16"	SAE Flat Washer	
H8.	10	7/16"	Split-Lock Washer	
H9.	1	3/4"-10, 5" Length	Hex Head Bolt	
H10.	1	3/4"	USS Flat Washer	
H11.	1	3/4"	Split-Lock Washer	
H12.	3	1/4"-20, 2" Length	Cup Point Set Screw	
H13.	8	#10	USS Flat Washer	

6. Recommended Routing of Air Tubing & Wire

The below figures are a recommendation of the routing paths for both the air tubing & the wiring. Verify routing paths, wire lengths, & fuse/relay component locations before cutting the included wire. Reference Section 9 (On-Vehicle Electrical Installation) for a detailed electrical connection guide.

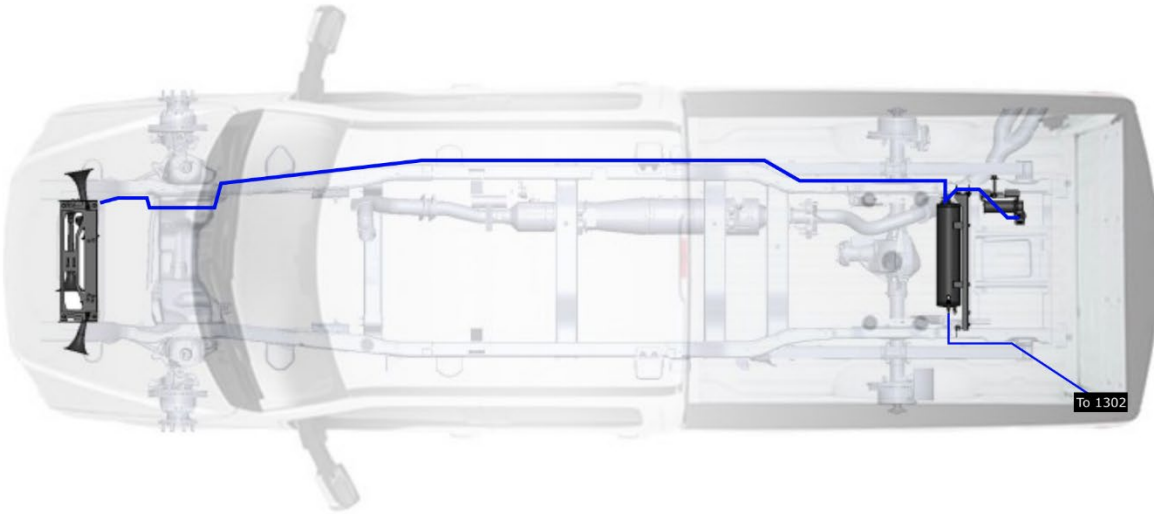

Figure 2- Recommended Air Tubing Routing

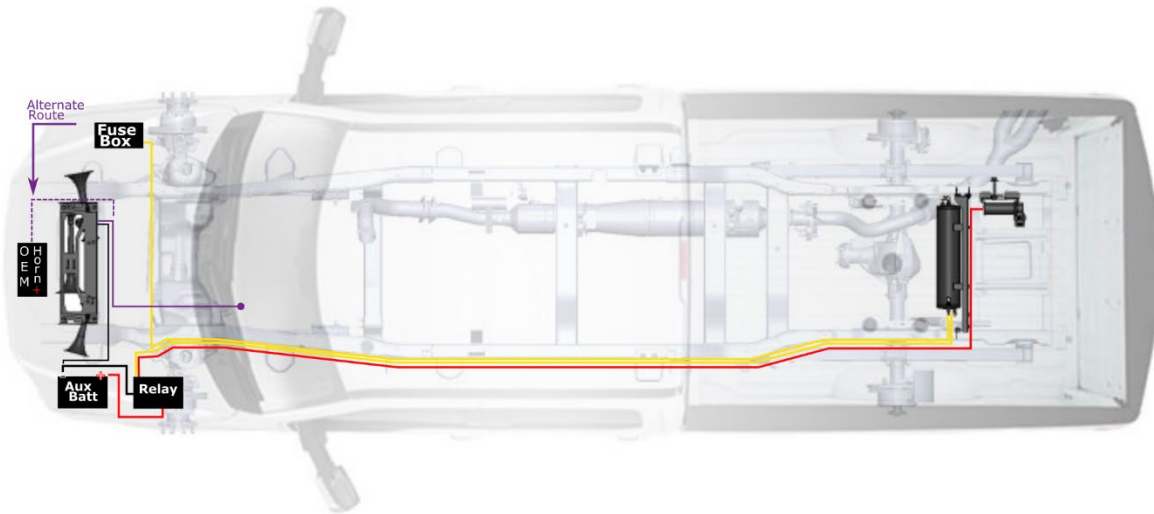

Figure 3- Recommended Electrical Routing (Grounding Points Not Shown)

7. Bench Assembly

7.1. Air Horns – Disassembly & Preparation

1. Remove all three (3) air horns from the mounting base.
2. Discard the (white) plastic shipping covers on each air horn driver & discard the mounting plate.
3. The included hardware will not be re-used.
4. Detach & remove the air tubing that connects the horns together.



Figure 4- Air Horn Disassembly & Separation

5. Unscrew each trumpet from its respective driver & set aside.



Figure 5- Trumpet Removal & Solenoid Installation

6. Using KLEINN JUICE, apply a few drops onto the male threads of the (middle) horn driver and install the solenoid valve (included in the horn box) **with the arrow pointing towards the horn driver.** Reference the following figure.
7. Using KLEINN JUICE, install the included compression fitting onto the other end of the solenoid as shown in the following figure.

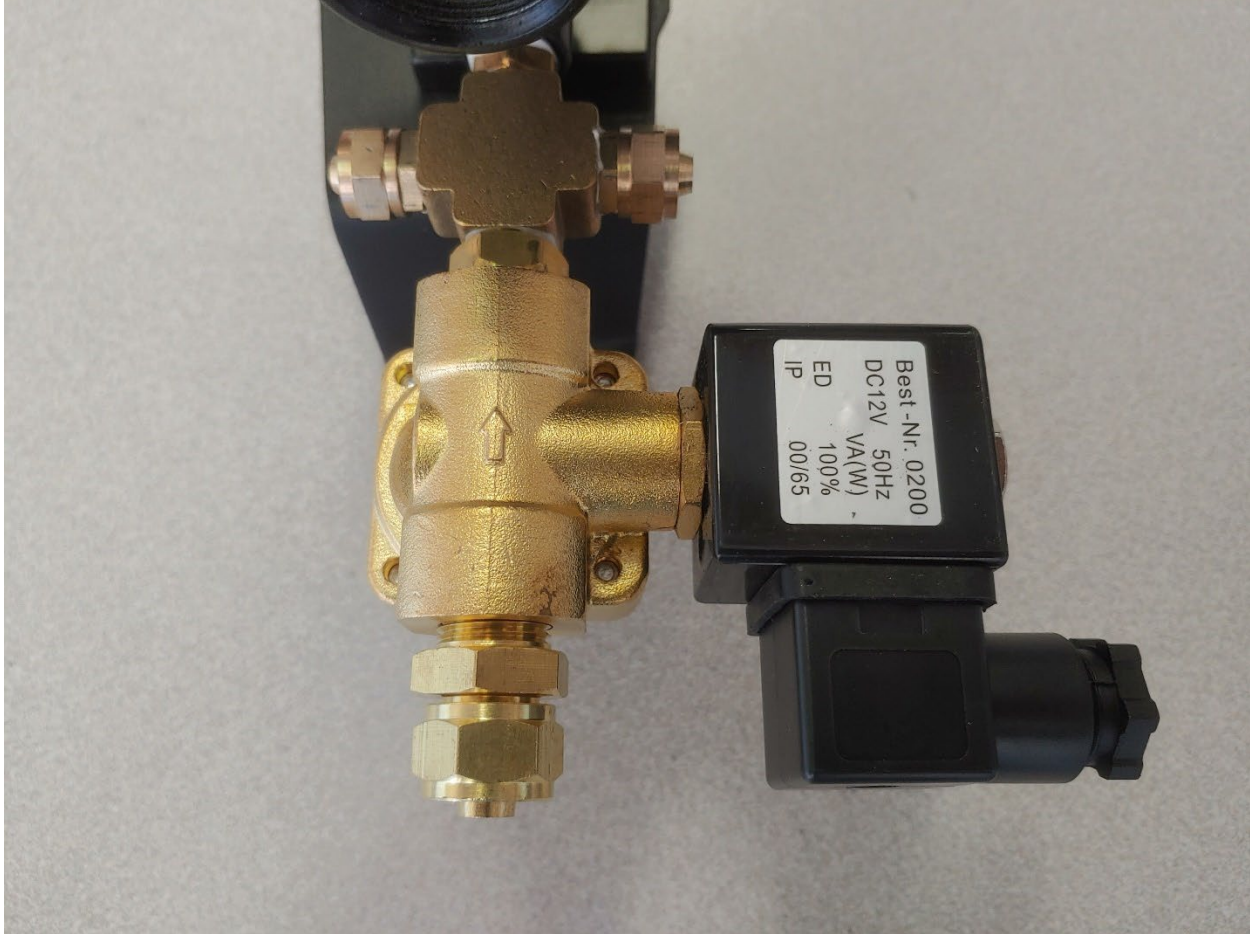

Figure 6- Solenoid Installation (Close Up)

7.2. Air Horns – Drivers-to-Bracket Installation

1. Install the air horn drivers onto the Horn Mounting Plate (see the below figure) using the following hardware:
 - a. All (Qty:6) of Hardware H1
 - b. Qty 6 of H2 & H4
 - c. Qty 12 of H3
2. Initially, hand tighten all fasteners.
3. **DO NOT** use the Ore Rubber Damper when installing the Ore Mount onto the Horn Mounting Plate.
 - a. Use the hardware included with the Ore Mount to install the Ore onto the mounting plate.-

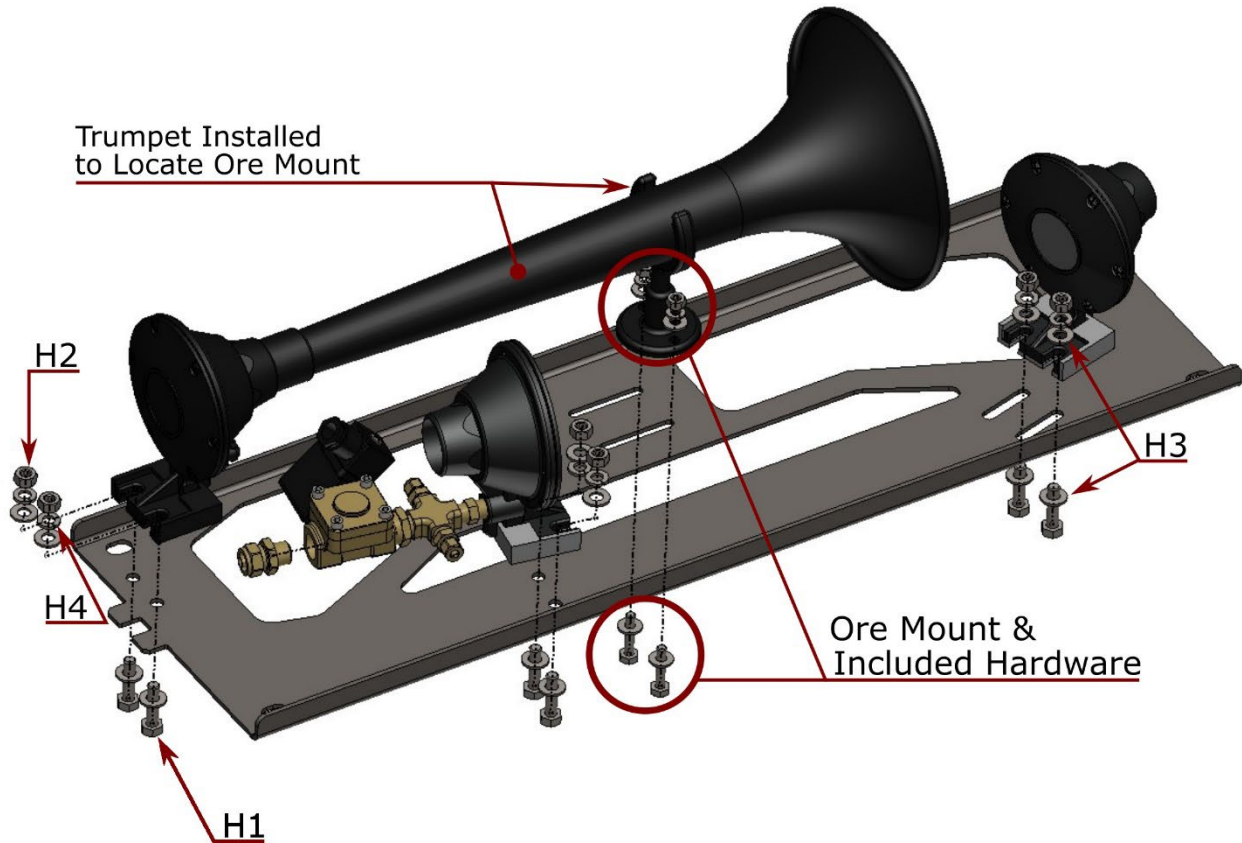

Figure 7- Horn Driver Installation

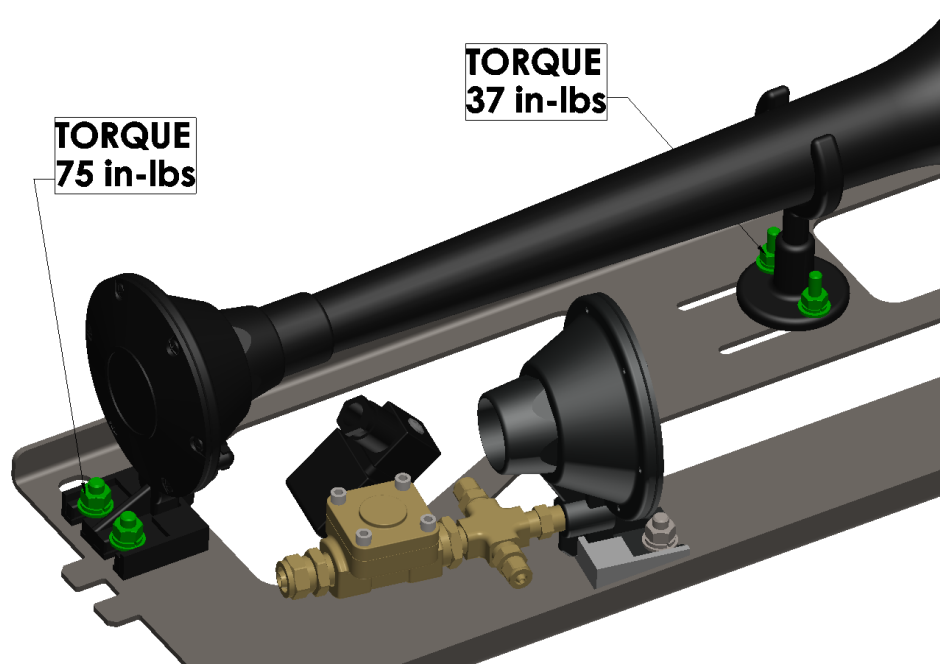

Figure 8- Torque Requirements for Horn Setup

4. Final tighten the highlighted (green) hardware per the above figure.

7.3. Compressor – Setup & Installation

1. Detach the compressor leader hose & retain for future use.

WARNING!!! The Air Compressor Leader Hose is sealed to the compressor with liquid sealant. HIGH HEAT IS REQUIRED in order to remove the hose from the compressor without damaging the compressor head!!!

2. Attach the compressor to the Compressor Bracket using the hardware included in the compressor box & hardware H13 (Qty 8) as shown in the below figure.

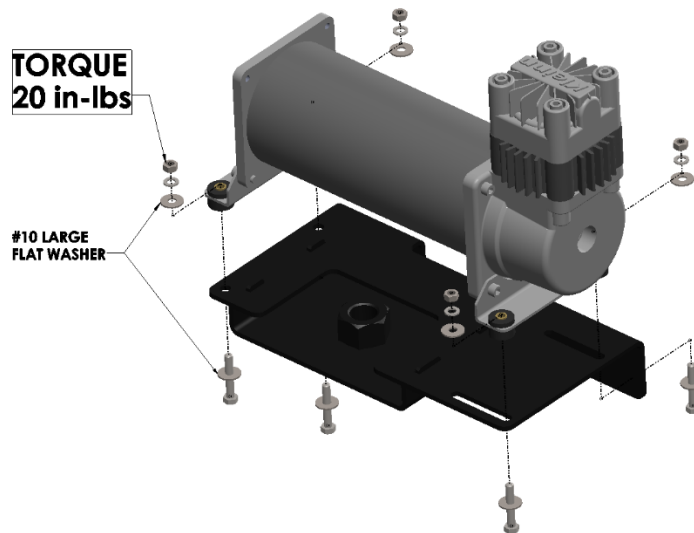

Figure 9- Compressor-to-Bracket Installation

7.4. Air Tank – Fittings & Air Tubing Installation

Using JUICE or PTFE Thread Tape, install the associated fittings onto the air tank as shown in the below figures.

Hand tighten the fittings, then further tighten 1/4 - 1/2 turn (or as needed) to match the orientation shown.

Install Guide

FSD23-734

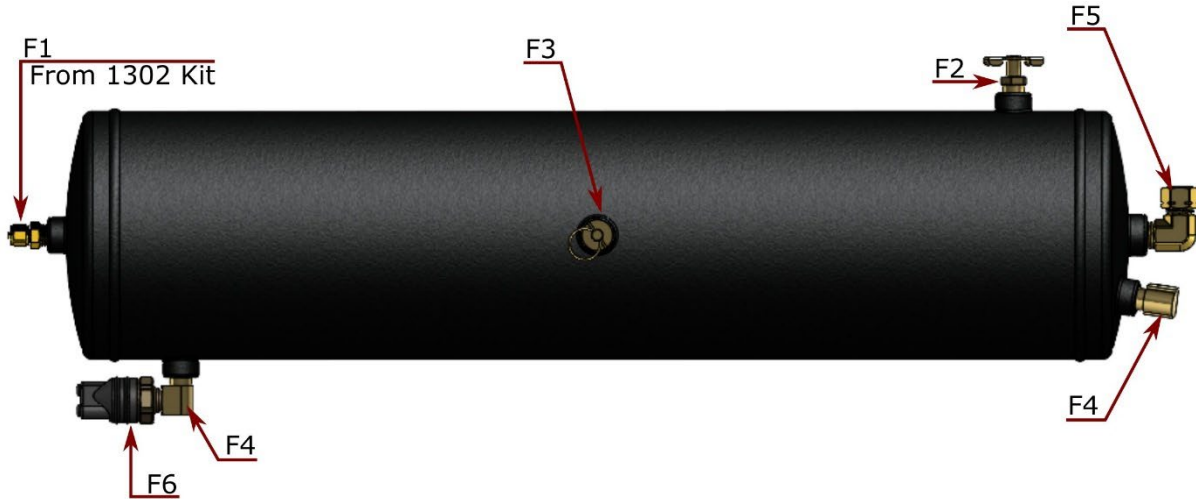

Figure 10- Air Tank Fittings, Orientation & Location, Top View

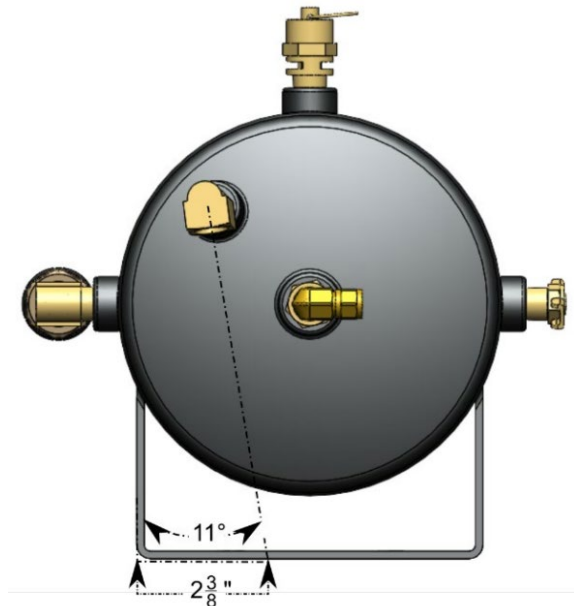

Figure 11- Air Tank Fittings, Orientation & Location, Side View

1. Attach the air tubing to tank fittings as shown in the below figure.
2. Attach the compressor leader hose (previously removed) onto the tank fitting as shown in the below figure.

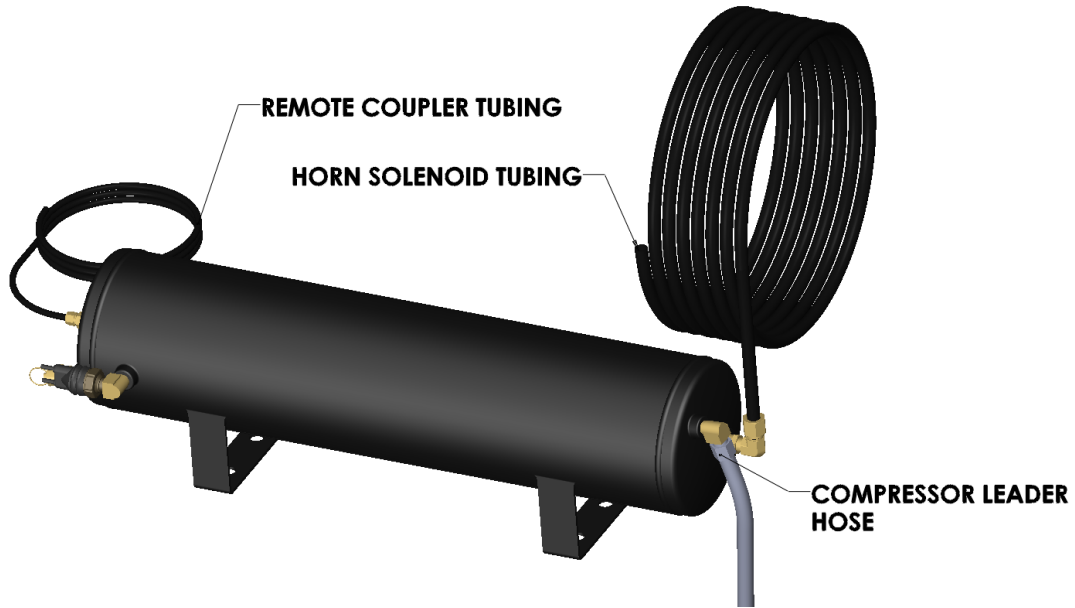

Figure 12- Air Tubing & Compressor Hose Installation

8. On-Vehicle Assembly

8.1. Horn Brackets – Passenger & Driver Side

1. If required, disconnect the front bumper fog light connector on the driver side frame rail as shown in the below figure.

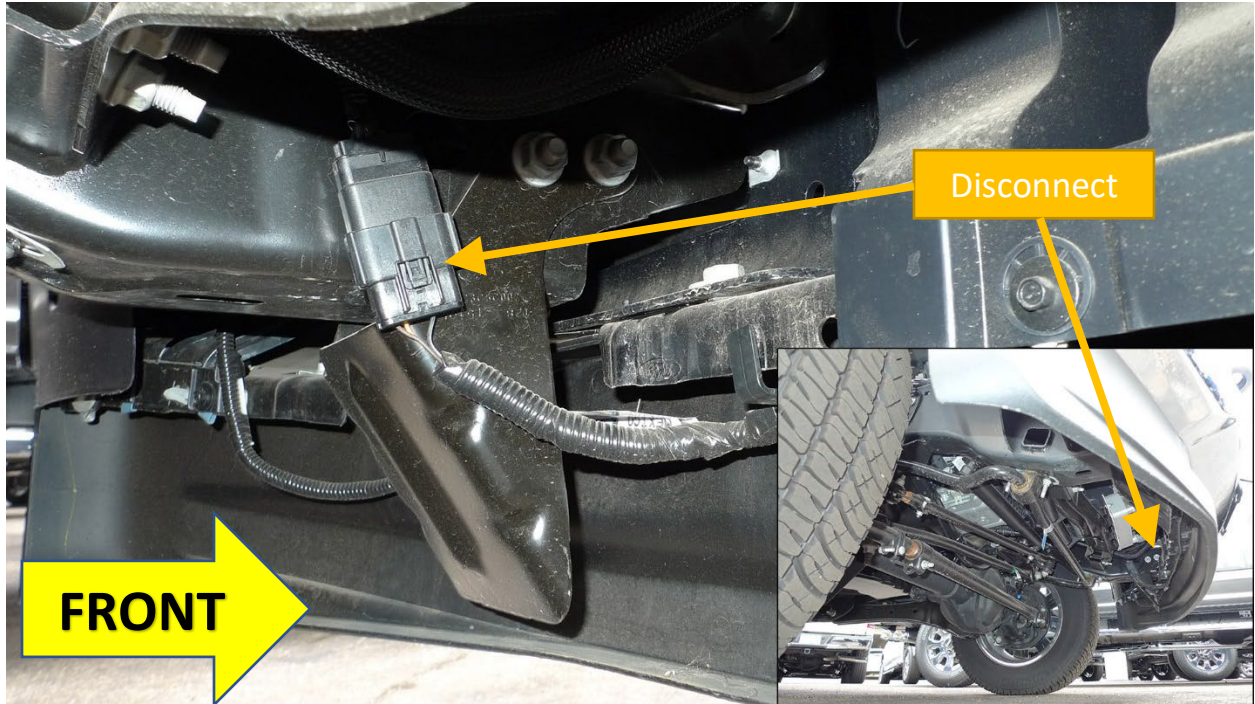

Figure 13- Fog Lights Connector, Location

2. Loosely install the Passenger Side Horn Mounting Bracket onto the chassis as shown in the below figure.
 - a. Use the Rectangular Washer as a spacer against the mounting bracket & the crossmember noted in the below figure (Detail A)
 - b. The flanged lock nuts will be reused

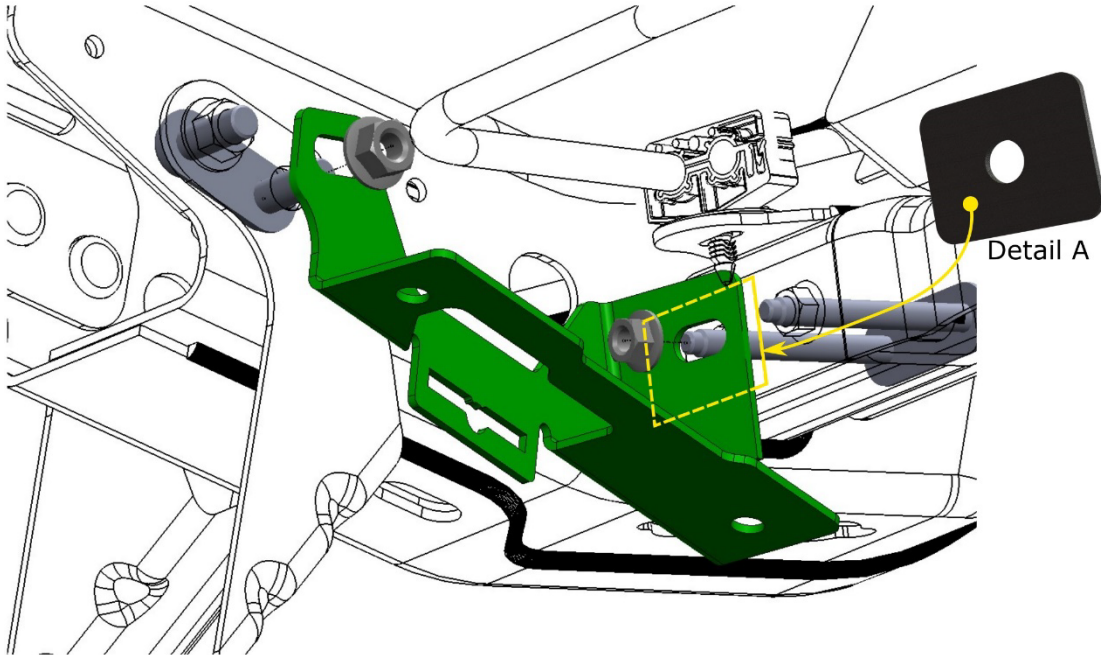

Figure 14- Passenger Side Mounting Bracket Installation 1

3. Use the following procedure & figure to fully secure the mounting bracket.
 - a. Insert a 7/16" Hex Bolt (hardware H5) into the alignment hole (REF. below figure).
 - b. Push the bracket upward until the 7/16 bolt contacts the frame rail.
 - c. Torque the flanged hardware to secure the bracket into place.
 - d. Remove the 7/16" Hex Bolt and set aside.

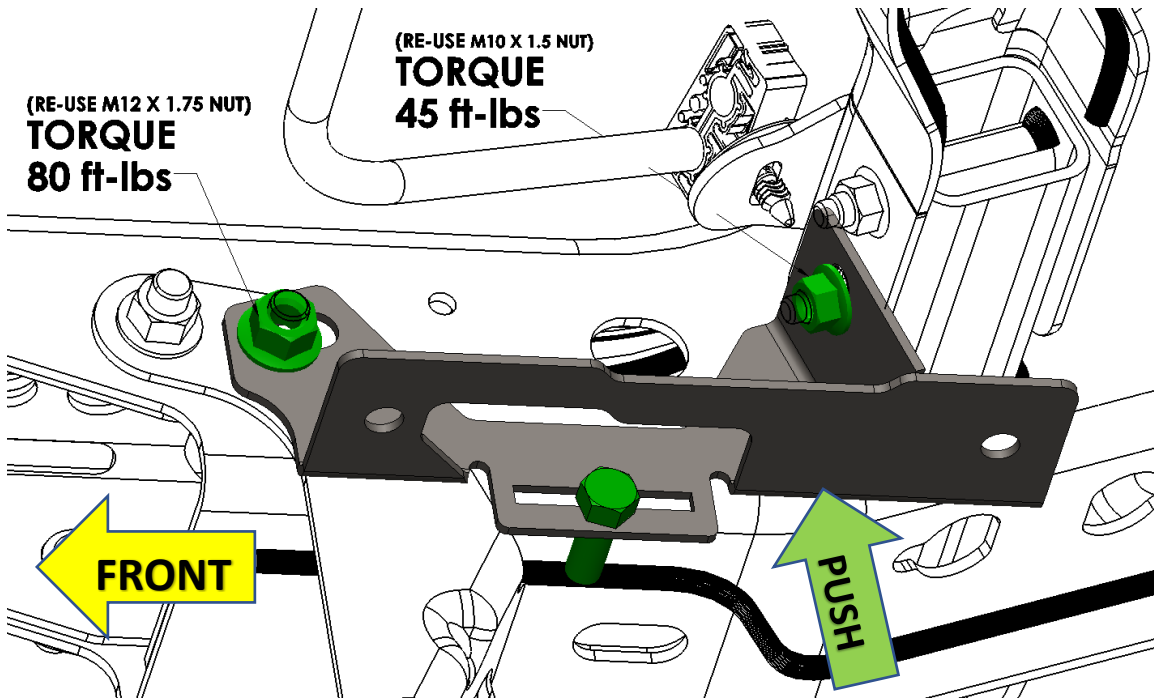

Figure 15- Passenger Side Mounting Bracket, Installation 2

4. Repeat Steps 2 & 3 with the Driver Side Horn Mounting Bracket & using the remaining Rectangular Washer & the 7/16" Hex Bolt (alignment purposes) as with the passenger side bracket. See the below figure.

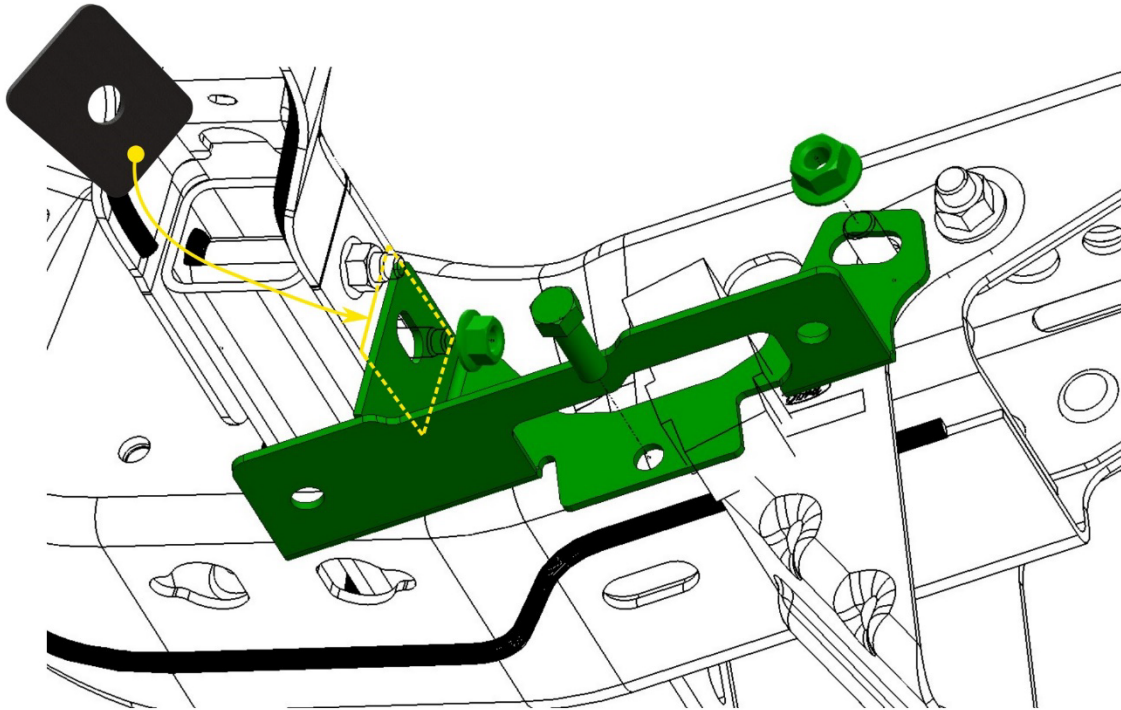

Figure 16- Driver Side Mounting Bracket, Installation

8.2. Horn Brackets – Main Bracket

1. Install the populated Horn Mounting Plate using the following steps & the below figure:
 - a. Insert the plate onto the passenger side bracket at a slight angle
 - b. Pivot the mounting plate upwards
 - c. Align the holes on the plate with the corresponding holes in the driver side bracket.

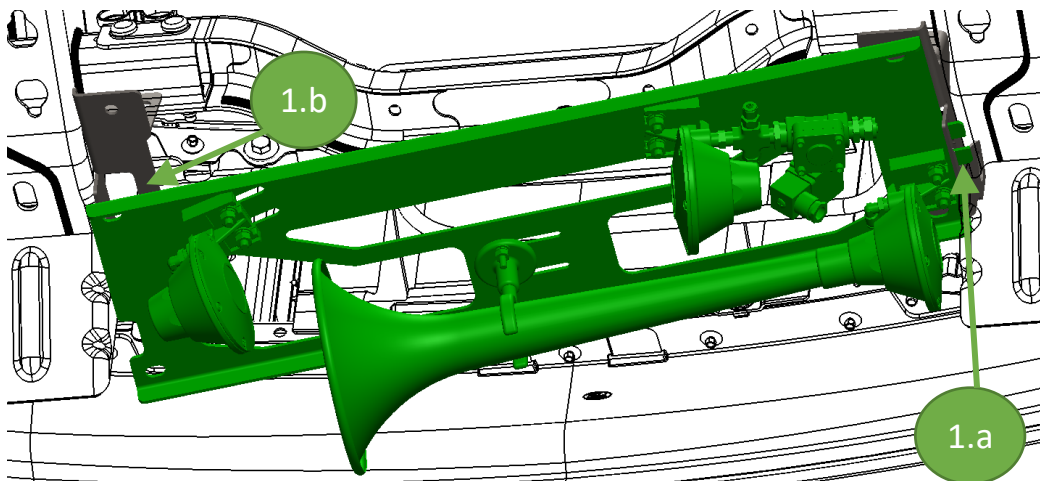

Figure 17- Horn Mounting Plate, Placement

2. Insert the hardware H5, H6, H7, & H8 and torque, as shown in the below figure.

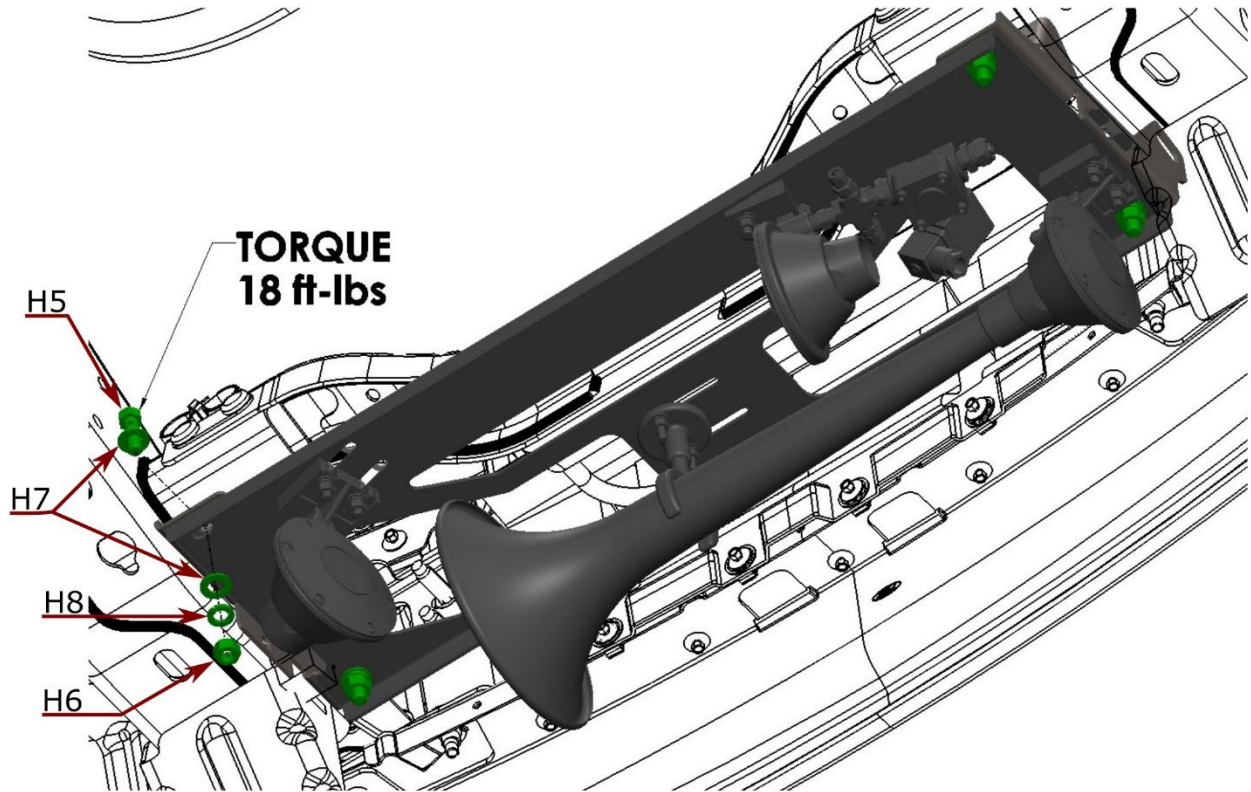

Figure 18- Horn Mounting Plate, Installation

8.3. Air Tank Installation – Passenger Side Nut Plates

1. Lower & remove the spare tire from the back of the vehicle. Consult the owners manual if necessary.
2. Ensure you have immediate access to all of the 2" Cup Point Set Screws (Hardware H12).
3. Identify the passenger side frame pocket (see below) where the first nut plate will be installed.

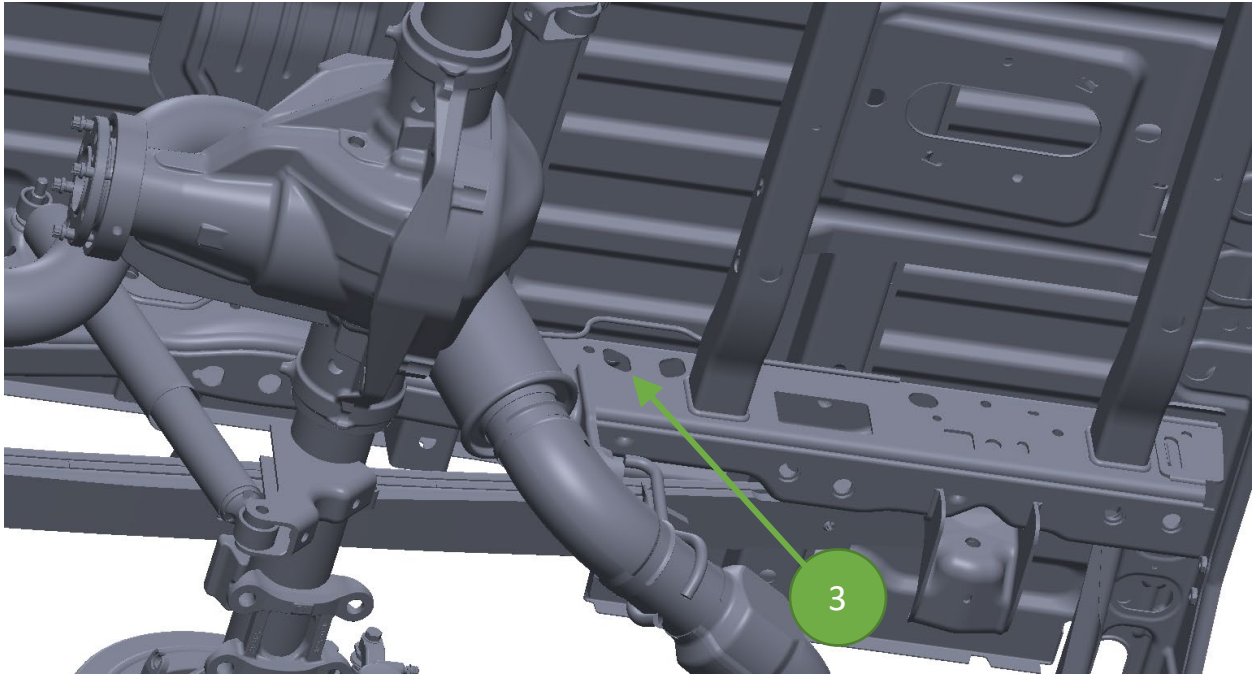
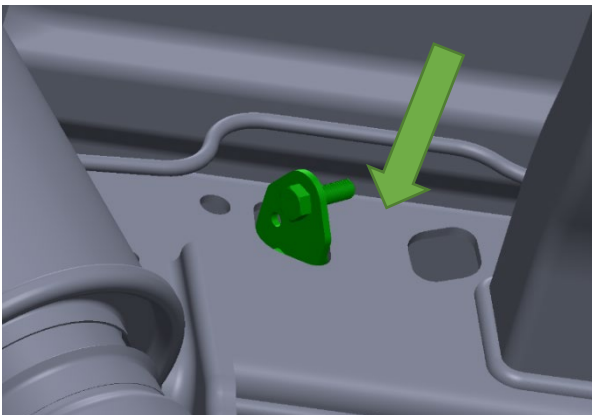
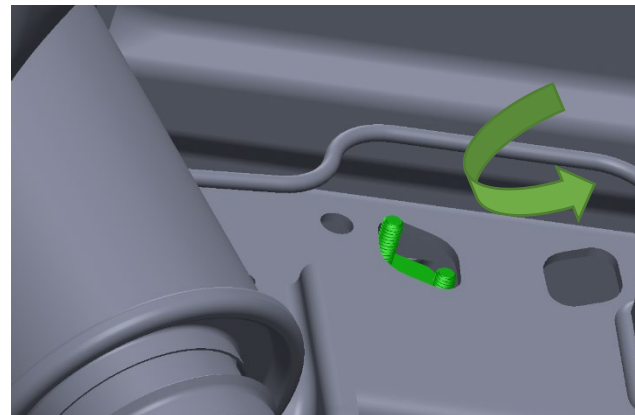

Figure 19- Passenger Side Nut Plate Location

4. Manipulate the Nut Plate into the frame opening by holding the threads and pushing the plate through, at an angle. Do not drop the nut plate into the frame.
5. Pivot the nut plate (from within the frame) and pull the plate outwards so the threads orient with the hole profile



Step 4



Step 5

Figure 20- Passenger Side Nut Plate Installation 1

6. While Holding onto the nut plate, **fully thread a set screw** into the nut plate so that the set screw presses the nut plate up against the frame rail wall. This will hold the nut plate in position.
7. Re-align the nut plate as needed to fit the hole profile as shown below.
8. Repeat the process with the second frame pocket directly behind the first one.

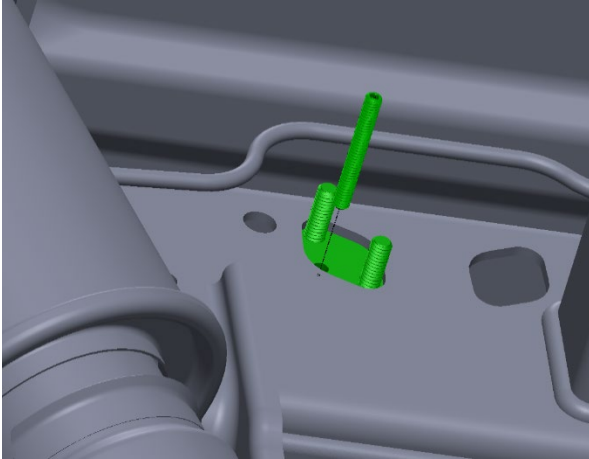

Step 6

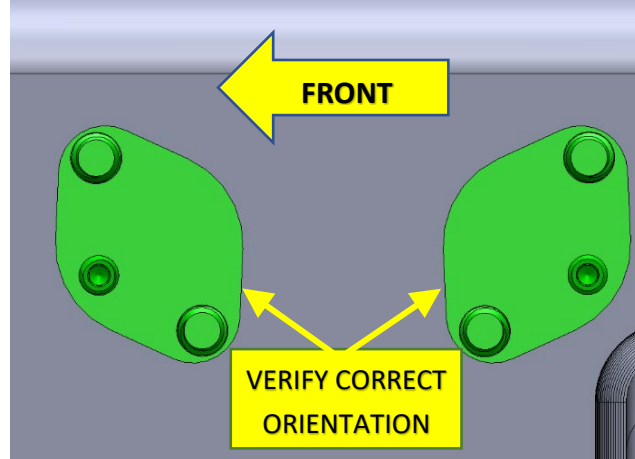

Step 8

Figure 21- Passenger Side Nut Plate Installation 2

8.4. Air Tank Installation – Driver Side Nut Plate

1. Using a Trim Panel Removal Tool, detach the three (3) plastic push pins from the wiring harness on the inside of the frame rail (driver side) shown below. **Use caution when removing these pins as they will be re-used.**

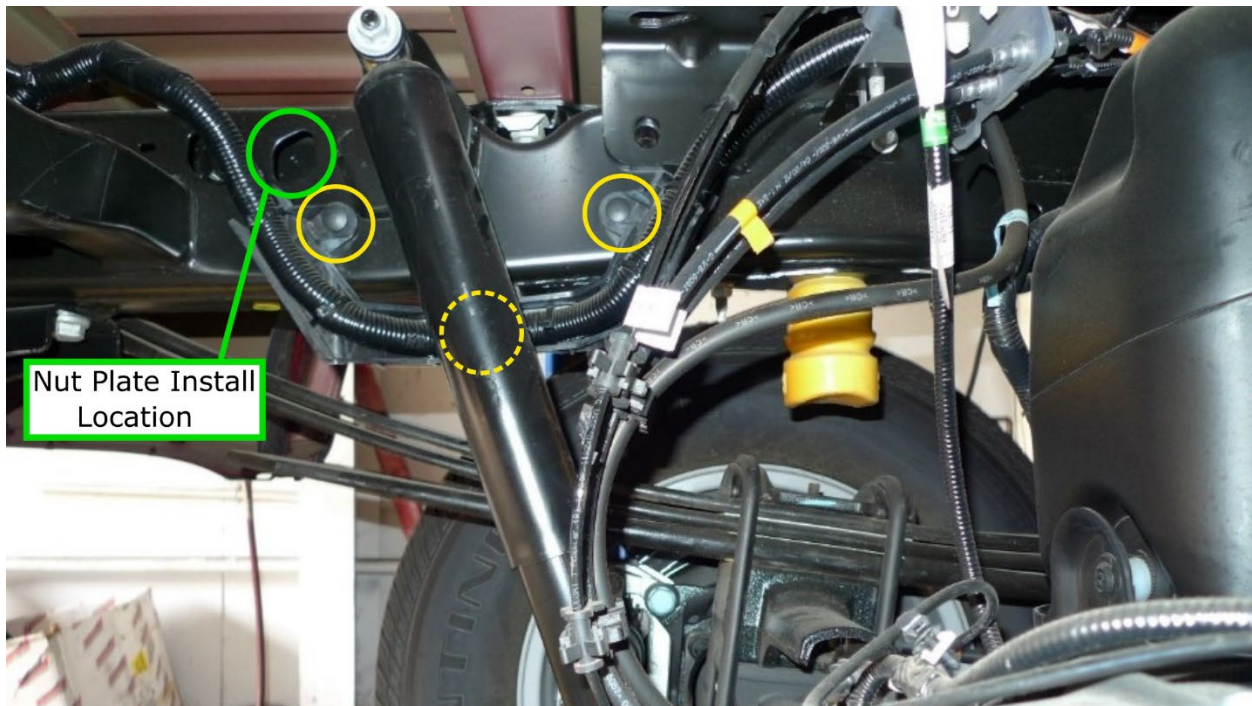

Figure 22- Plastic Push Pin Locations, & Driver Side Nut Plate Install Location

2. Install the Nut Plate onto the frame using the same techniques as the passenger side nut plates.



Figure 23- Driver Side Nut Plate Installation

8.5. Air Tank Installation – Air Tank Bracket Installation

1. Insert the Driver Side Air Tank Bracket **behind the wiring harness** & onto the threaded studs of the nut plate as shown in the below figure.
2. Secure the bracket into place using hardware H2, H3 & H4. **Do not fully tighten the hardware.**
3. At this point, you may elect to remove the set screw on the nut plate or loosen to allow for bracket alignment in a future step.

NOTE: It may be easier to install this bracket after the Primary bracket has been placed onto the vehicle.

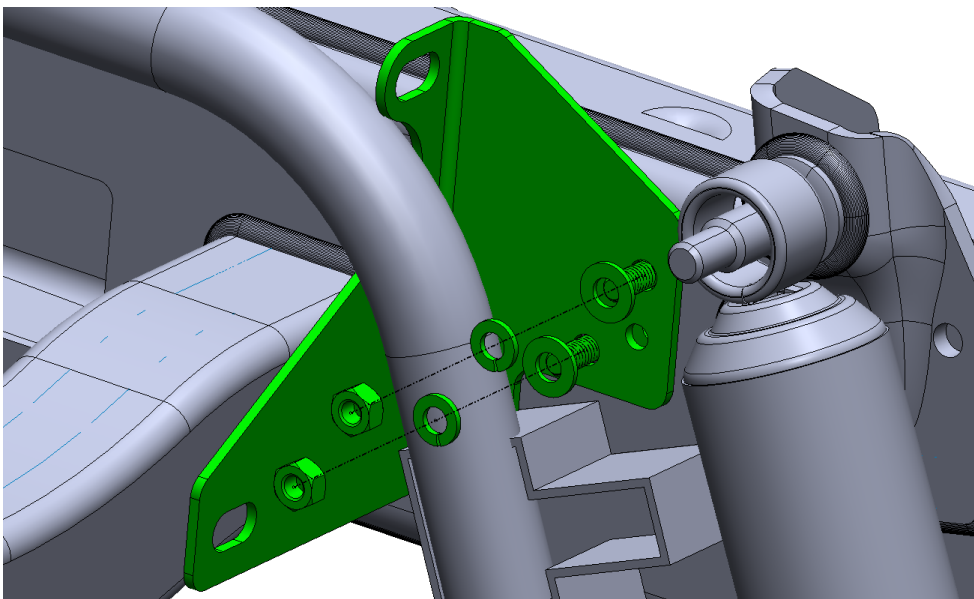

Figure 24- Driver Side Air Tank Mounting Bracket

4. Install the Air Tank Passenger Side Bracket over the studs of the passenger side nut plates. See the below figure.

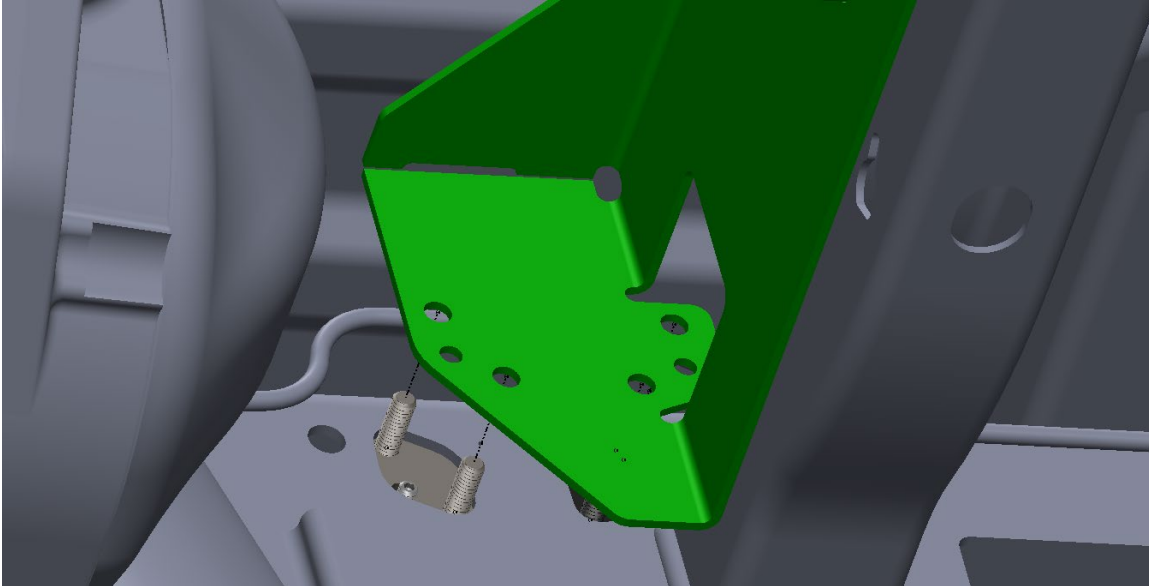

Figure 25- Passenger Side Air Tank Bracket, Placement

5. Pull both brackets away from the crossmember and insert the tank mounting hardware H5, H6, H7 & H8 as shown in the below figure.

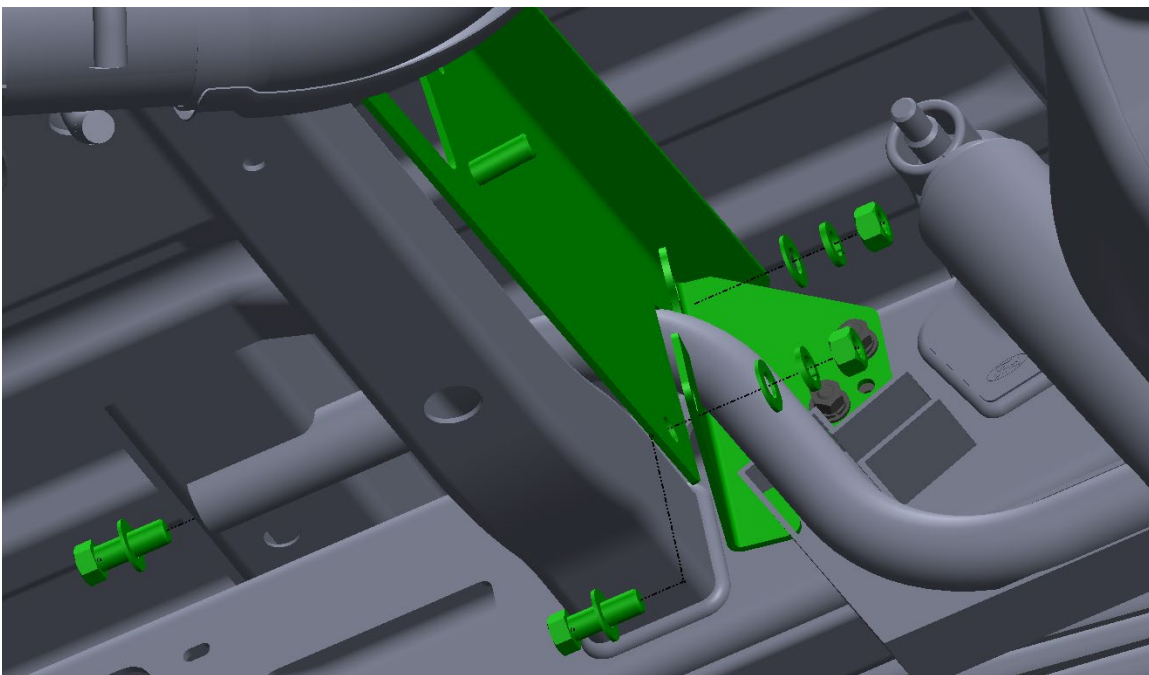

Figure 26- Tank Hardware Placement

6. Fully install the passenger side bracket & loosen / remove the set screws if required, as shown in the below figure.

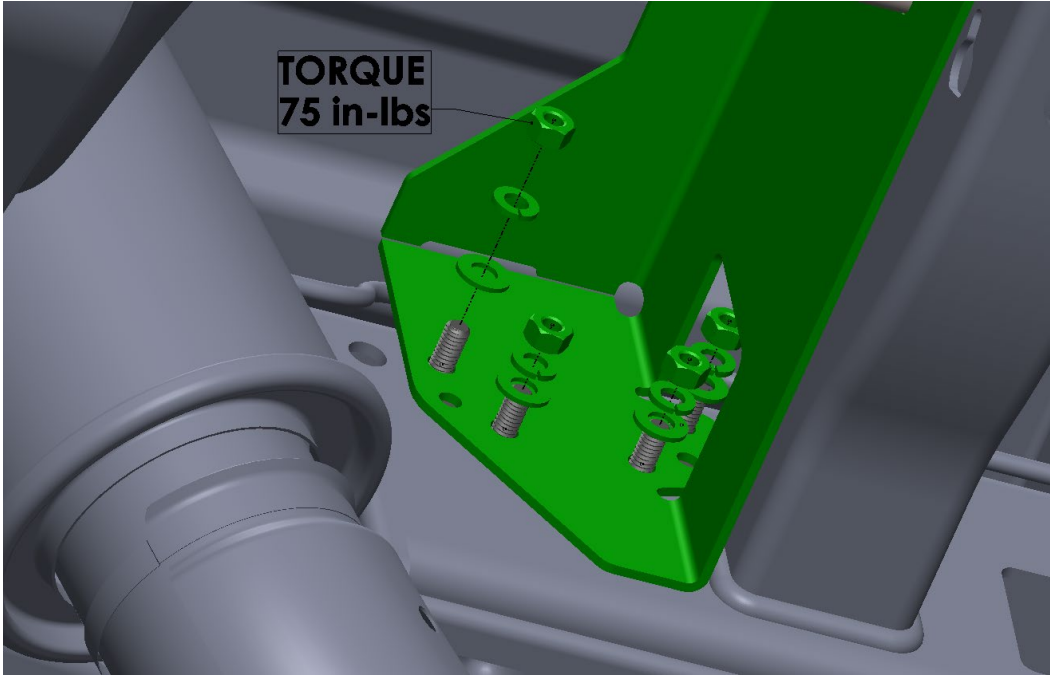

Figure 27- Passenger Side Bracket Installation

7. Final tighten the bracket hardware in the following order:
 - a. Tighten the frame side hardware to the below torque specification.
 - b. Tighten the bracket-to-bracket hardware to the below torque specification.

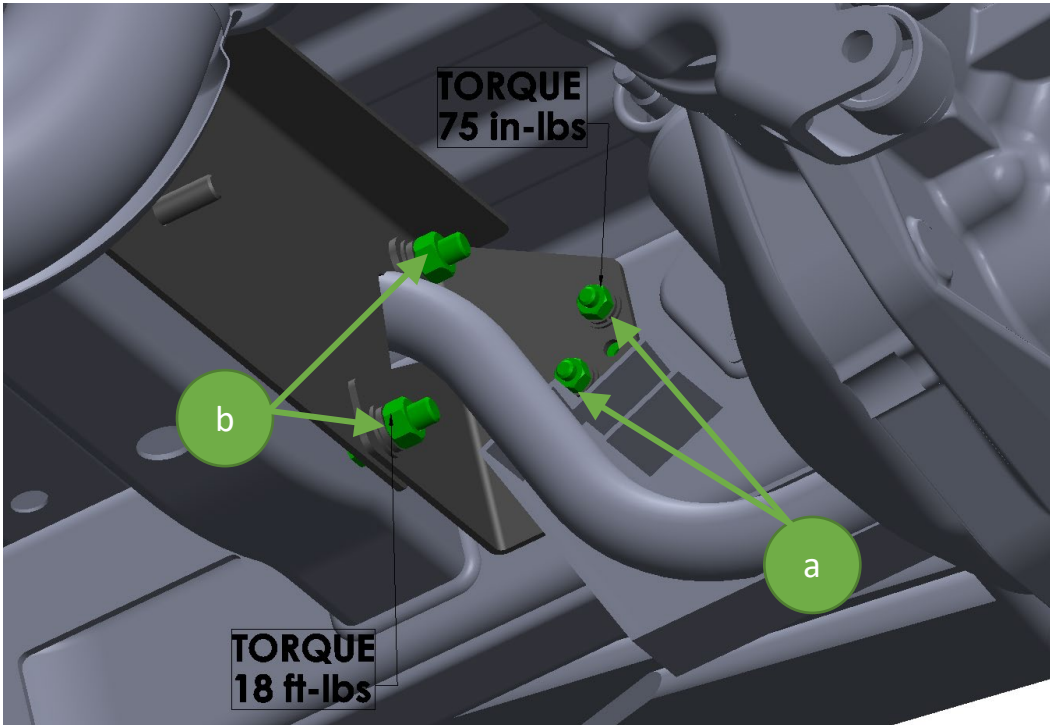

Figure 28- Final Installation, Bracket Hardware

8. Install the Air Tank onto the bracket, ensuring the compressor hose is channeled through the bracket correctly, as shown in the below figure.

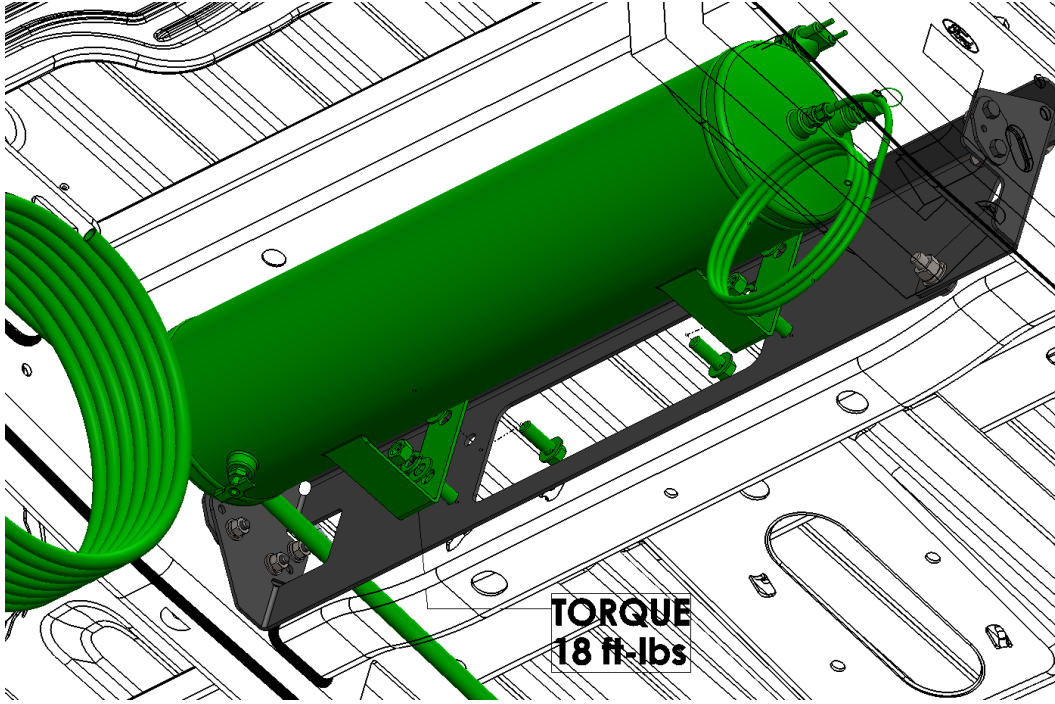

Figure 29- Air Tank Installation & Torque Specification

9. Reinstall the 3 plastic push pins that were detached from the frame in Section 8.4, Step # 1

8.6. Air Compressor & Bracket Installation

Attach the compressor bracket onto the chassis using hardware H9, H10 & H11 as shown in the below figure. Ensure O2 Sensor is routed correctly & the frame does not get distorted from over-tightening.

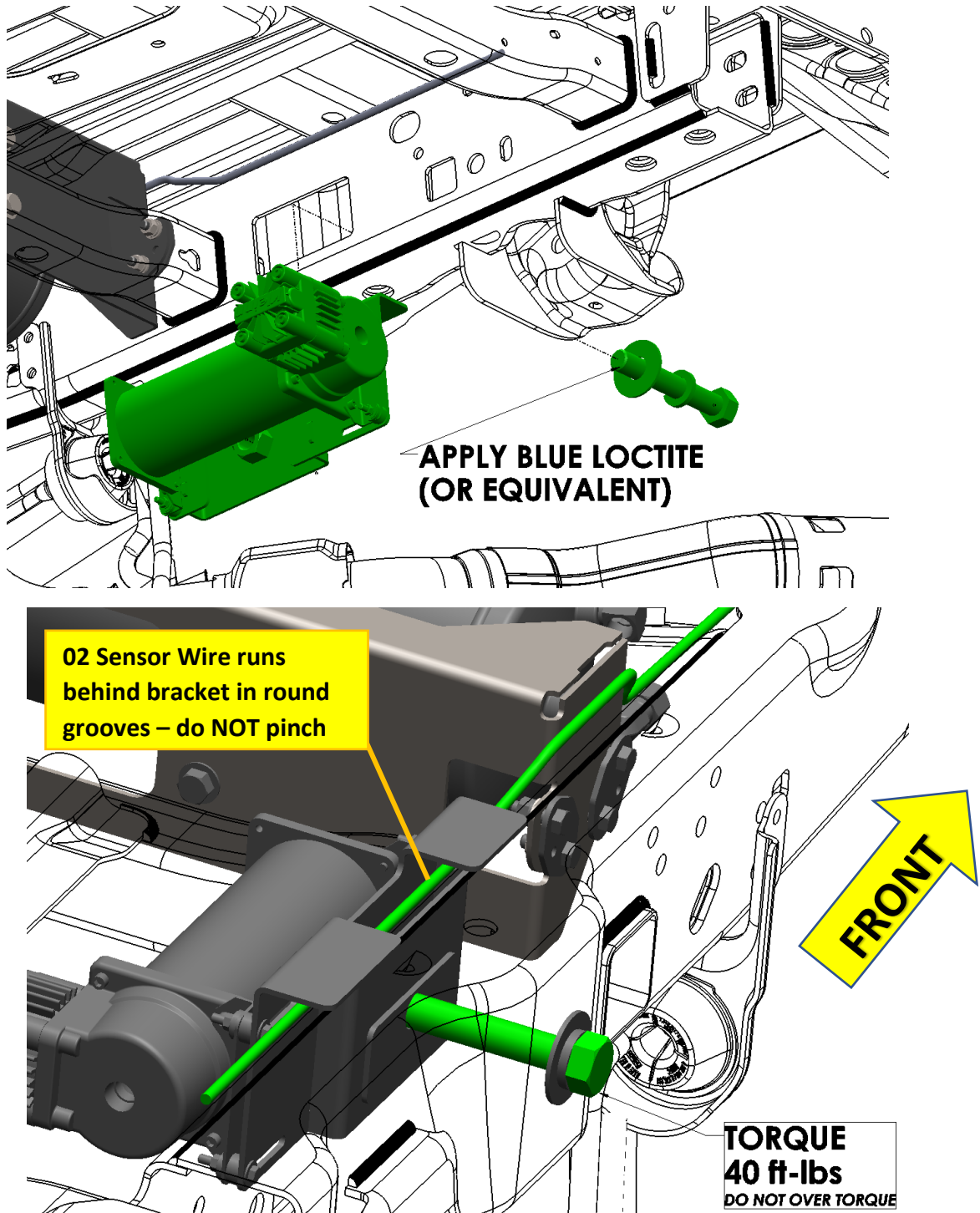

Figure 30- Compressor Bracket Installation

8.7. Final Connections & Installation

1. Reinstall the small & medium length trumpets onto the horn drivers as shown below.
2. Torque the hardware to the specification shown below.
3. Plumb the horns together using the supplied 3/8" air tubing. Route as desired.
4. Plumb the horn solenoid air inlet to the tank using the included 1/2" air tubing. Route the tubing as desired or follow the recommended routing diagram shown in Section 6.

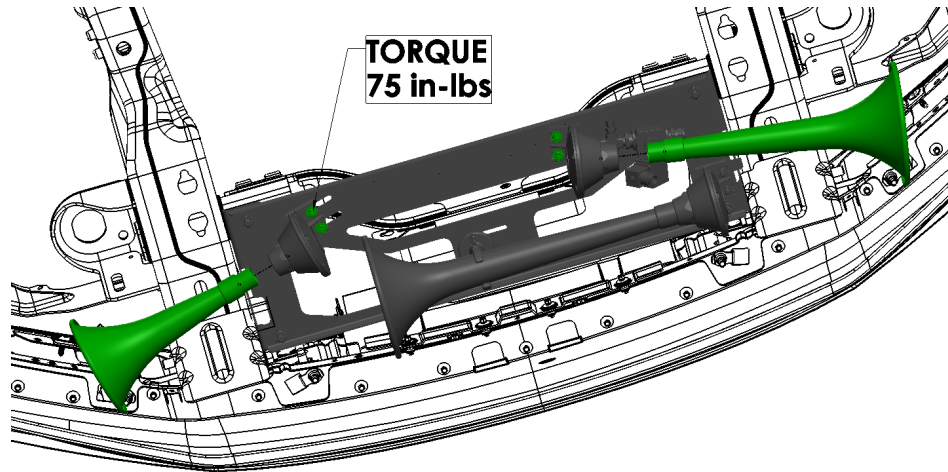

Figure 31- Final Trumpet Installation

5. Connect the compressor leader hose from the tank to the compressor head using JUICE (thread sealant) as shown below.
6. Attach the air filter to the compressor inlet or use the supplemental instructions (included in the compressor box) to set it up as a snorkel.

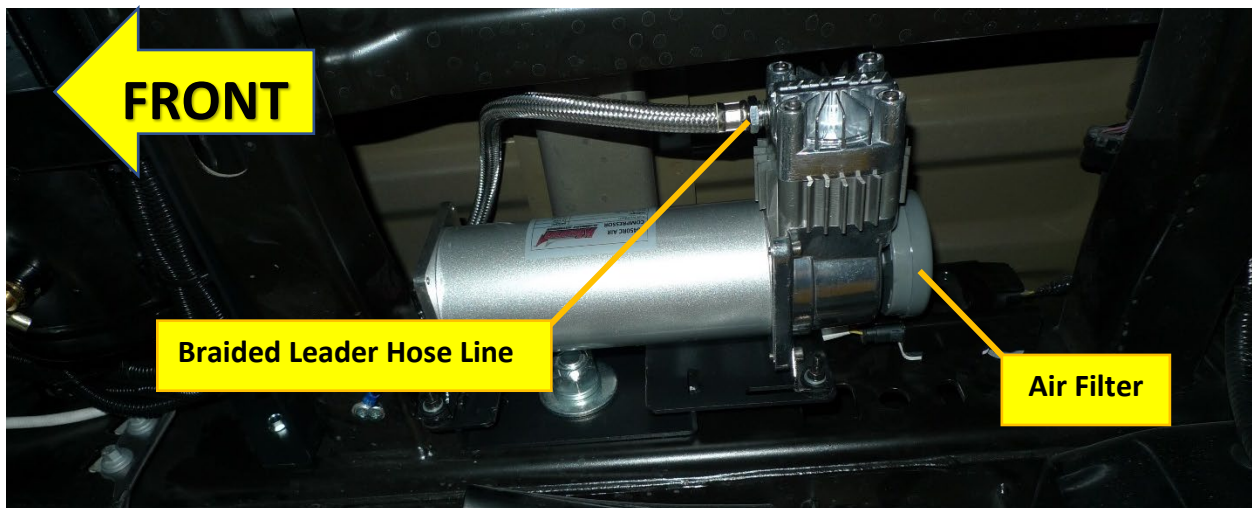

Figure 32- Final Compressor Hookups

7. Install the 1302 quick connect kit in any desired location. Ensure there is a path to route the air tubing from the tank to the 1302 kit.
8. Use KLEINN Juice for the NPT threads as needed.

NOTE: Use the exploded view below as a guide when installing the 1302 kit.

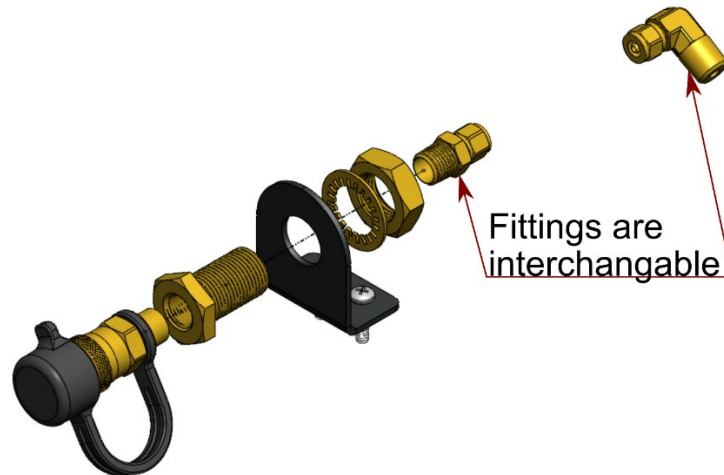

Figure 33- 1302 Quick Connect Kit, Assmebly View

9. Raise / Reinstall the spare tire

9. On-Vehicle Electrical Installation

It is recommended to disconnect the vehicle battery prior to performing any electrical work.

9.1. Attach Relay & Fuse to Vehicle

Locate a suitable location under the hood and install the fuse housing & relay.

- For the Fuse: Select an area close to the POS (+) battery terminal
- The fuse housing can be attached to the vehicle body panel using the supplied screws
- The relay can be attached to the vehicle body using the supplied self-tapping screws

9.2. Install Horn Button

Locate a desirable & accessible location to install the horn button. There should be a minimum of 1" clearance behind pushbutton to allow for the switch to be mounted and wired easily.

Factory upfitter switches may be used at the installers/customers discretion. Consult the owners manual or OEM documentation if using this option.

9.3. Route Wiring & Make Connections

Route wiring as desired and make the appropriate connections per the below figure. Use the included wiring loom and crimp connectors as desired.

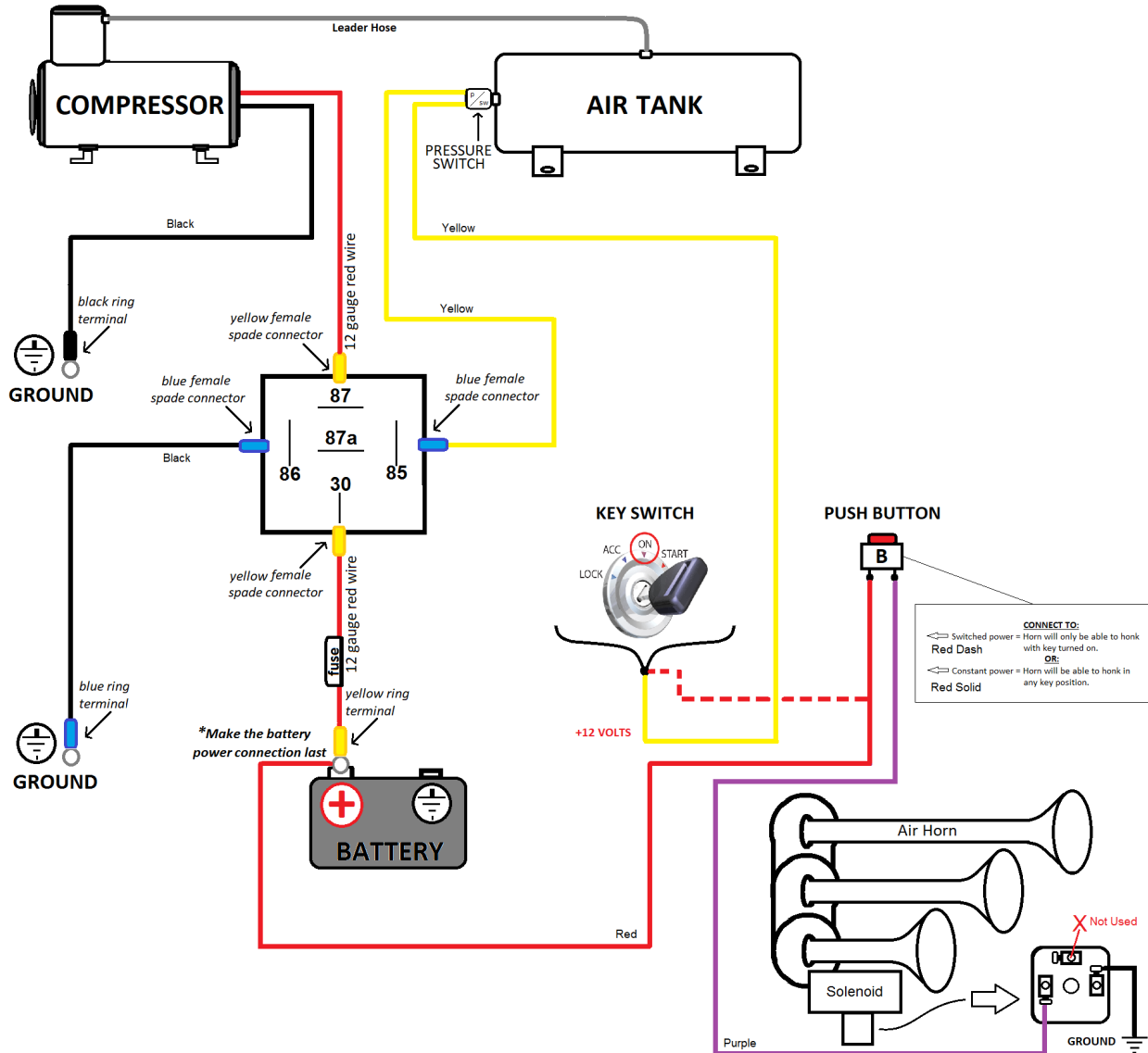

10. Testing the Air System

It is recommended to check your wiring for shorts & continuity & double checking your connections prior to reconnecting the battery.

It is recommended to check the drain valve on the tank and ensure it is fully closed.

10.1. Air Compressor Test

1. Start the vehicle & allow the air compressor to run and fill up the tank.

NOTE: The compressor should turn off after tank reaches \approx 150 PSI. This should take between 2-5 minutes. If the compressor runs excessively, a leak may be present in the system.

2. Allow the tank to drain via, the horns (if installed), the Inflator kit, or the tanks drain valve.
3. Wait for the compressor to start up again to replenish the air supply.
4. Wait for the compressor to turn off when tank is fully pressurized.

10.2. Air Horn Test

Ensure all persons nearby have adequate hearing protection & provide courtesy warning to neighbors before testing the horn system.

!!WARNING!! NEVER operate the air horns with ears in close proximity to the trumpets or in an enclosed space without SUBSTANTIAL HEARING PROTECTION for all persons closer than 50 feet from the vehicle.!!

1. Activate the air horns by pressing the horn button briefly. Horns should sound as expected and be loud.

The horn sound & loudness will diminish as the air tank loses pressure. Repeat, if desired, until the compressor turns on and begins refilling the air tank.

10.3. Quick Connect Coupler Test

The quick connect coupler can be used to run the included INF-1 tire inflator kit or certain air tools.

1. If needed, allow the air compressor to refill the air tank.
2. Attach the INF-1 inflator kit and inflate tires
3. Optionally, an air blow gun/nozzle or an air nailer can be used to test the quick connect coupling.

11. Maintenance

!!WARNING!! Operating the air compressor above its maximum pressure rating may damage the internal components and/or cause unsafe system conditions. It is recommended not to exceed 150 PSI pressure in the system.!!

This air compressor is equipped with automatic thermal overload protection. If thermal overload is triggered, the safety circuit will reset after 30 minutes.

This air compressor is oil-less, Never lubricate or add liquids to this compressor.

Monthly or every 10 Hours of Compressor Use:

- Drain the moisture from the air tank via the tank's drain valve.

Yearly or 12,000 Miles

- Replace the compressor's air filter element. – Replacement frequency depends on operating & environmental conditions.
- Remove road grime or mud from components & brackets.
- Inspect all mounting fasteners to ensure they remain secure. Tighten as needed.
- Inspect electrical connections & loom for damage. Repair/Replace as needed.

12. Warranty Information

Thank you for purchasing this Air System. If you experience any unexpected problems during installation, or part failure at any time, please contact KLEINN Support.

KLEINN MANUFACTURER LIMITED DEFECT WARRANTY:

Kleinn Automotive Accessories warrants this product to the end-user, when properly installed and under normal conditions of use, to be free from defects in workmanship and materials for a period of one year from the provided date of purchase to the original purchaser of the product. This warranty does not cover abuse, operation in a manner inconsistent with the product's design, or damage resulting from exposure to the elements. If the defect is considered "under warranty", Kleinn will, at its option, repair or replace the product free of charge to the original purchaser. Kleinn is not liable for any installation charges, loss or damage of any kind incurred in the replacement or repair of any warranted product.

© Kleinn Automotive Accessories 2019, All rights reserved.

PO Box 91278 Tucson, AZ 85752

Phone: [\(520\) 579-1531](tel:5205791531)

Web: www.Kleinn.com



Install Guide

Record of Revisions

FSD23-734

Revision	Description	Date	Approval
A	Initial Revision	9/15/2023	AG
B	Updated the KLEINN logo Updated the KLEINN "name" on the cover page, below the vehicle image Added warning on pg. 15, underneath #1 on Section 7.3 Updated the KLEINN "name" in the warranty box on pg. 35 Updated the KLEINN "name" below the warranty box on pg. 35 Updated color template based on new logo design	4/1/2024	AG