



INTAKE SYSTEMS FOR VEHICLES LISTED ARE 50 STATE LEGAL. SEE KNFILTERS.COM FOR CARB STATUS ON EACH PART FOR A SPECIFIC VEHICLE.

INSTALLATION INSTRUCTIONS

57-3097
CHEVROLET
2016-17 Malibu
L4-2.0L Turbo

TOOLS NEEDED:

- flat blade screw driver
- ratchet extension
- 13mm socket
- 10mm socket
- 4mm allen key
- 3mm allen key
- t20 torx
- side cutter pliers

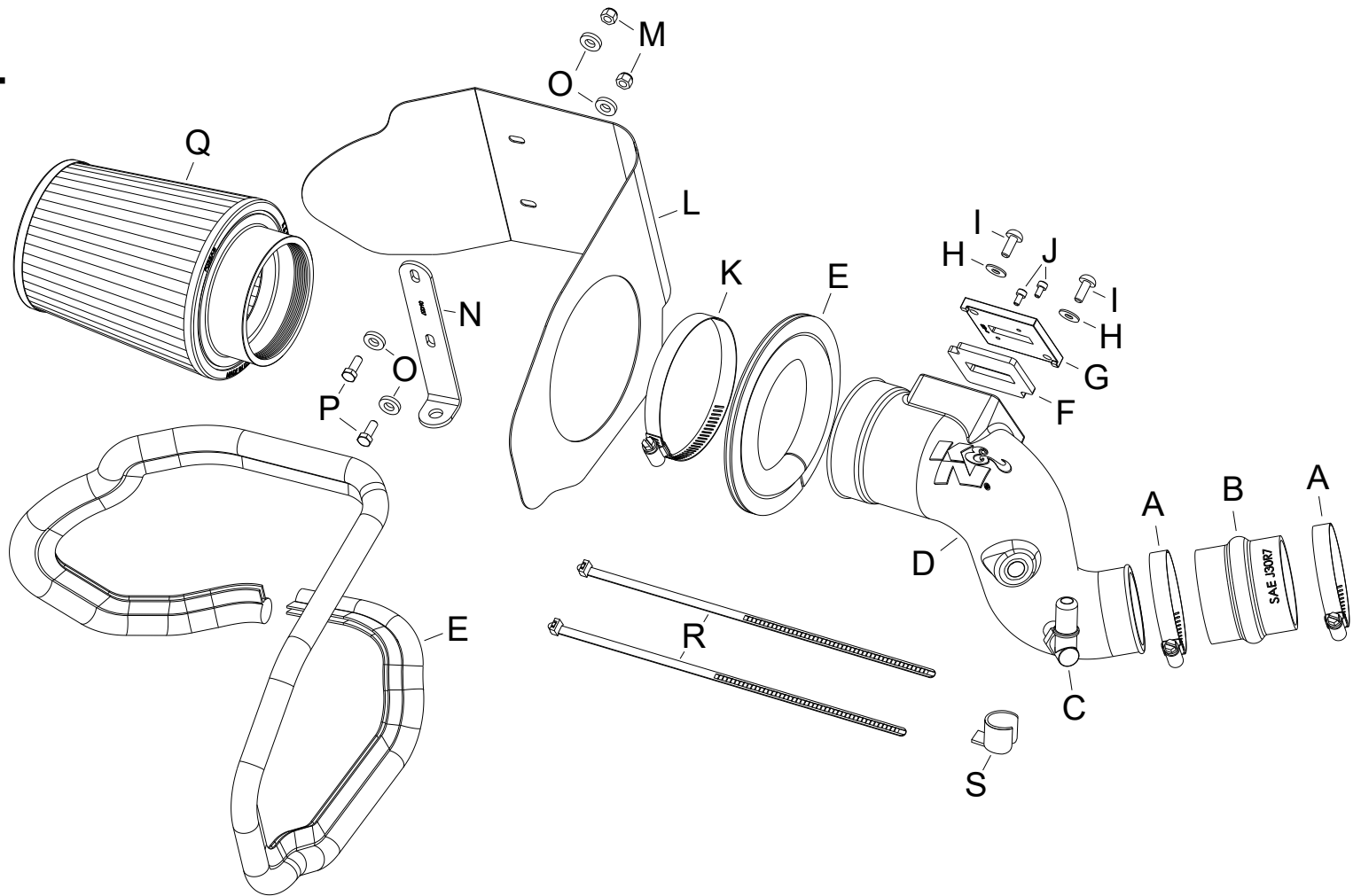

PARTS LIST:

Description	Qty.	Part #	Description	Qty.	Part #	Description	Qty.	Part #
A HOSE CLAMP #40	2	08554	G ADAPTOR; #420, NYLON 6/6 GF	1	21515-1	M NUT; 6MM NYLOCK, HEXHEAD	2	07512
B HOSE; HUMP 2.5"ID X 2.5"L	1	084018	H WASHER; 6MM FLAT	2	08269	N BRACKET; "L"	1	064337
C VENT; 90*, 1/4NPT TO .600"	1	088028	I BOLT; M6 X 1 X 16MM	2	07730	O WASHER; 1/4"ID X 5/8"OD	4	08275
D INTAKE TUBE (LO)	1	087342A	J BOLT; M4 - .7 X 8MM	2	07733	P BOLT; M6-1 X 16MM	2	07812
E EDGE TRIM (66")	1	102472	K HOSE CLAMP #60	1	08624	Q FILTER CHARGER	1	RU-4630
F GASKET; 3/16 PORON	1	09069	L HEAT SHIELD	1	073240	R CABLE TIES; 11" BLACK	2	21590
						S QUICK DISCONNECT TOOL	1	088027

If you need any assistance please call 1-800-858-3333 to speak with a representative in our Customer Service Center before returning the product.

NOTE: FAILURE TO FOLLOW INSTALLATION INSTRUCTIONS AND NOT USING THE PROVIDED HARDWARE MAY DAMAGE THE INTAKE TUBE, THROTTLE BODY AND ENGINE.

TO START:

1. Turn off the ignition and disconnect the negative battery cable.
NOTE: Disconnecting the negative battery cable erases pre-programmed electronic memories. Write down all memory settings before disconnecting the negative battery cable. Some radios will require an anti-theft code to be entered after the battery is reconnected. The anti-theft code is typically supplied with your owner's manual. In the event your vehicles anti-theft code cannot be recovered, contact an authorized dealership to obtain your vehicles anti-theft code.



2. Disconnect the mass air sensor electrical connection.



3. Disconnect the crank case vent hose.
NOTE: On 2017 and later vehicles, it will be necessary to use the special tool provided (088027) to disconnect the crank case vent line. Snap the tool onto the vent tube and then slide it upwards until it unlocks the retaining clips and then disconnect the crank case vent line.



4. Loosen the hose clamp securing the intake tube to the turbo inlet. Lift up the air filter housing, detach the intake hose from the turbo and then remove the complete intake system from the vehicle.
NOTE: K&N Engineering, Inc., recommends that customers do not discard factory air intake.



5. Install the heat shield mounting bracket (064337) onto the heat shield as shown using the provided hardware.



6. Cut the provided edge trim into two sections, one section will be 15-1/2" long and the other section will be 46" long.



7. Install the edge trim into the hole and around the heat shield as shown.

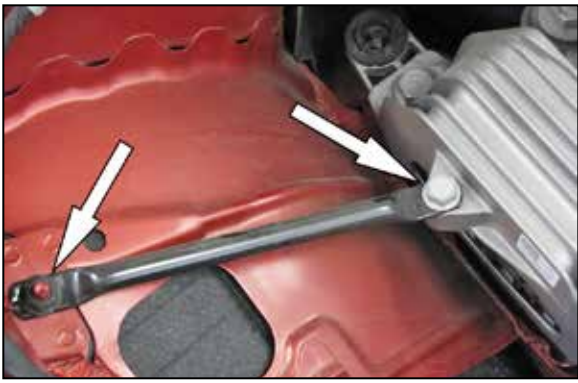

8. Remove the engine mount brace bolt and loosen the nut shown.

NOTE: The bolt will be reused in the next step.



9. Install the heat shield assembly onto the engine mount and secure with the factory bolt from the previous step.



10. Install the provided hump coupler (084018) hose onto the K&N® intake tube and secure with the provided hose clamp.



11. Install the 90° NPT vent fitting into the K&N® intake tube as shown.

NOTE: Plastic NPT fittings are easy to cross thread. Install the vent fitting "hand" tight, then turn it two complete turns with a wrench.



12. Install the provided gasket onto the K&N® mass air sensor adapter.



13. Remove the mass air sensor from the factory air filter housing.



14. Install the mass air sensor into the K&N® mass air sensor adapter and secure with the provided hardware.

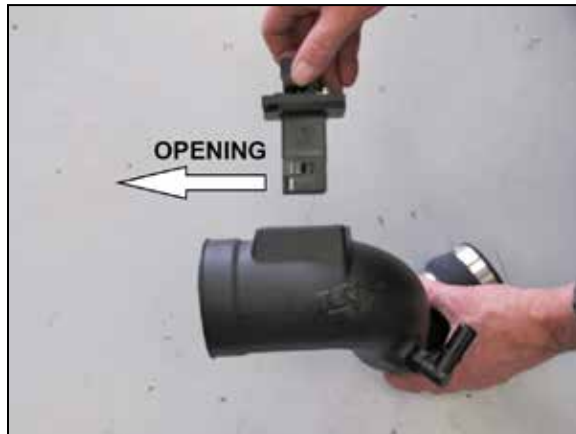

15. Install the mass air sensor assembly into the K&N® intake tube so that the opening in the sensor is towards the air filter end of the intake tube.



16. Install the K&N® intake tube assembly through the opening in the heat shield and then onto the Turbo inlet. Adjust the tube and heat shield for best fit and then secure them with the hose clamp and hardware.



17. Install the air filter onto the K&N® intake tube and secure with the provided hose clamp. Adjust the tube and heat shield for best fit and then secure them with the hose clamp and hardware.

NOTE: Drycharger® air filter wrap; part # RC-4630DK is available to purchase separately. To learn more about Drycharger® filter wraps or look up color availability please visit <http://www.knfilters.com>®.



18. Connect the crank case vent hose to the fitting installed into the K&N® intake tube.



19. Reconnect the mass air sensor electrical connection.



20. Using the provided tie wraps, secure the mass air sensor electrical cable to the A/C line as shown.



21. Reconnect the vehicle's negative battery cable. Double check to make sure everything is tight and properly positioned before starting the vehicle.

22. The C.A.R.B. exemption sticker, (attached), must be visible under the hood so that an emissions inspector can see it when the vehicle is required to be tested for emissions. California requires testing every two years, other states may vary.

23. It will be necessary for all K&N® high flow intake systems to be checked periodically for realignment, clearance and tightening of all connections. Failure to follow the above instructions or proper maintenance may void warranty.

ROAD TESTING:

1. Start the engine with the transmission in neutral or park, and the parking brake engaged. Listen for air leaks or odd noises. For air leaks secure hoses and connections. For odd noises, find cause and repair before proceeding. This kit will function identically to the factory system except for being louder and much more responsive.

2. Test drive the vehicle. Listen for odd noises or rattles and fix as necessary.

3. If road test is fine, you can now enjoy the added power and performance from your kit.

4. K&N Engineering, Inc., requires cleaning the intake system's air filter element every 100,000 miles. When used in dusty or off-road environments, our filters will require cleaning more often. We recommend that you visually inspect your filter once every 25,000 miles to determine if the screen is still visible. When the screen is no longer visible some place on the filter element, it is time to clean it. To clean and re-oil, purchase our filter Recharger® service kit, part number 99-5050 or 99-5000 and follow the easy instructions.

INTAKE SYSTEMS FOR VEHICLES LISTED ARE 50 STATE LEGAL. SEE KNFILTERS.COM FOR CARB STATUS ON EACH PART FOR A SPECIFIC VEHICLE.