

Nissan Armada V8, 5.6L 2011 – 2021

Nissan Patrol V8, 5.6L 2010 – 2022

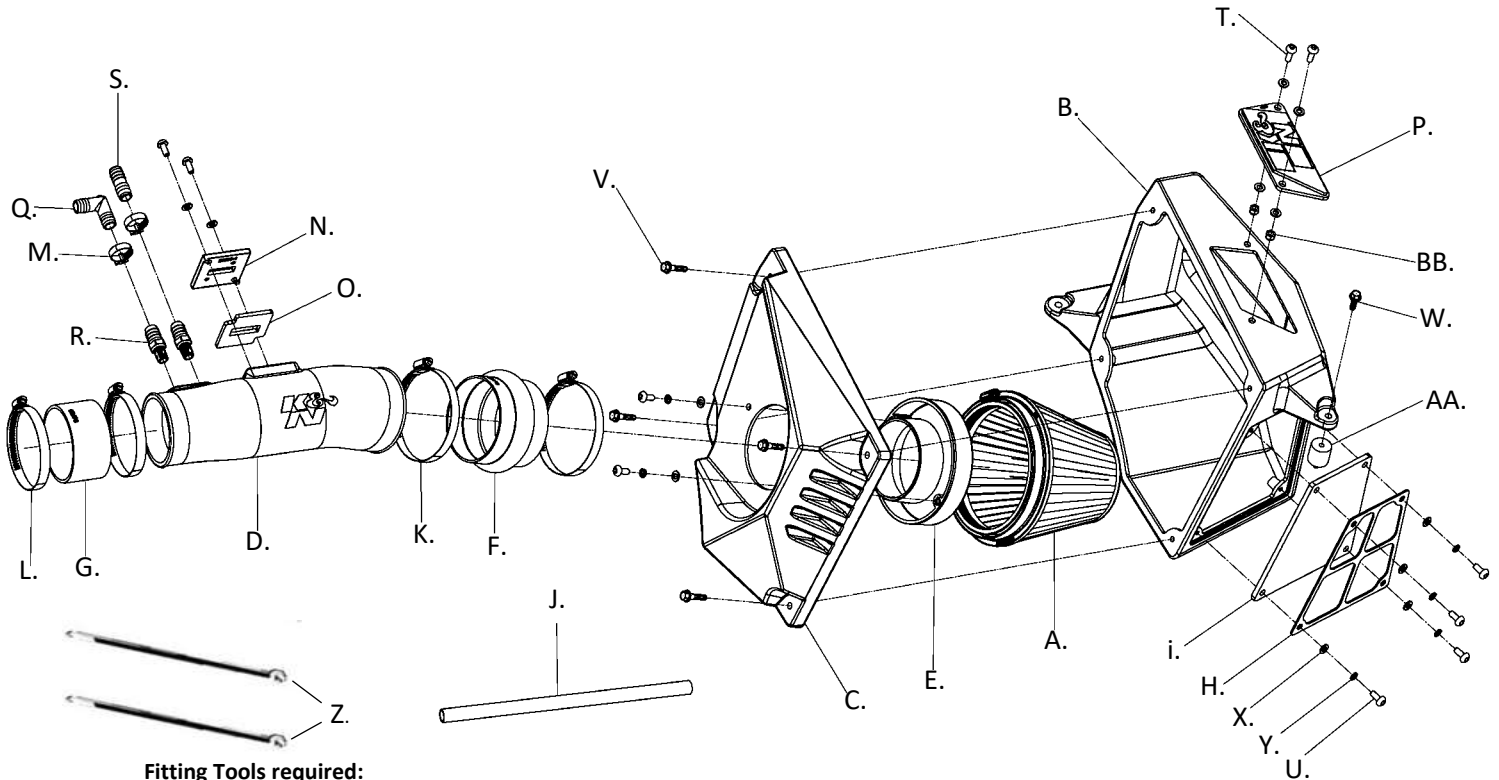

Fitting Tools required:

- 10mm Spanner.
- Side cutters
- Pliers
- 10mm Socket and Ratchet.
- Metric Hex key set.
- Flat Blade Screwdriver
- Ratchet Extension Bar

No	Part Number	Description	QTY.
A	RU-1048	6"FLG, 7-1/2"B, 4-1/2"T, 6"H	1
B	087433	AIRBOX, 57S-7070, MQ, XLHDPE	1
C	087434	LID; 57S-7070, MR, XLHDPE	1
D	087343A	TUBE; AIRCHARGER 63-6018, LP, XLHDPE	1
E	27300	ADAPTOR; 57-3058 #454	1
F	08418	HOSE; HUMP 4"ID X 3"L REINFORCED	1
G	08698	HOSE; 3.5"ID X 2"L REINFORCED	1
H	073287	MOUNTING PLATE; 57s-7070, MILD STL., TB/PC	2
i	971597	FOAM; 6.54" X 6.44" X .250"	1
J	5-7013	HOSE; 5/8"ID X 13"L	1
K	08645	HOSE CLAMP #64 STAINLESS	2
L	08620	HOSE CLAMP #56	2
M	08411	HOSE CLAMP; #10 MINI	2
N	21515-1	ADAPTOR; #420, NYLON 6/6 GF, BLACK	1
O	09069	GASKET; 57-2556, 3/16 PORON	1
P	08351-1	PLATE; K&N LOGO, CLEAR, 6.2" X 2.4" X .25"	1
Q	08072	VENT; 90 DEG, 5/8"HOSE, BLK PLASTIC QUICK CONNECT	1
R	82638	FITTING; VENT, 1/4"NPT, 5/8"BARB, STRT, ALUM	2
S	08048	FITTING; VENT, STRT, 5/8"OD BARB - 5/8"OD BARB	1
T	KIT20BHC3060	SCREW; M6 X 20MM, BUTTON HEAD CAP	2
U	07730	BOLT; M6 X 1.00 X 16MM , BUTTONHEAD, SS	8
V	1-1016	BOLT; M6-1 X 30, HEX/FLANGE	4
W	1-2038	BOLT; M6-1 X 20, HEX/FLANGE	1
X	08269	WASHER; 6MM FLAT, SS	12
Y	1-3025	WASHER; M6, SPLIT LOCK, ZINC	6
Z	21590	CABLE TIES; 11" BLACK	3
AA	02033	STUD; RUBBER MOUNT, M6 X 1, 1" T, M/F	1
BB	07512	NUT; 6MM NYLOCK, HEXHEAD, SS	2



57s-7070



Installation Instructions

1. Take the key from the ignition, disconnect the negative terminal from the battery.
2. Remove the two bolts that secure the decorative engine cover and then remove the cover from the engine. (Fig. #1)
2. Unclip the electrical harness plug from the Mass Air Sensor. (Fig. #2)
3. Completely unclip the MAS wiring loom from the airbox. (Fig. #2)
4. Release the spring clamps that secure the two CCV lines to the plenum then disconnect the CCV lines from the plenum. Also unclip the EVAP hose from the plenum (Fig. #3)
5. Loosen the hose clamp that secures the factory intake hose to the throttle body. (Fig. #4)
6. Remove the three mounting bolts that secure the factory air filter housing to the inner wing and carefully lift and remove the complete intake system from the vehicle. **NOTE: On 4-wheel drive applications it will be necessary to unhook the front differential vent line from the air filter housing.** (Fig. #5)
7. Install the #454 large round filter adapter onto the filter housing and secure using 2x M6 x 16 Button head bolts, flat & Split Washers (Fig. #6).
8. Install the air filter onto the round filter adapter and secure with the hose clamp that came with the filter (Fig. #7).
9. Install the foam prefilter onto the filter housing using the mounting plate, 4x M6 x 16 Button head bolts, flat & Split Washers (Fig. #8).
10. Fit the K&N logo plate into the airbox using (2x) M6 x 20 Button head screws, (4x) Flat Washers & 2x M6 Nylock Nuts (Fig. #9).
11. Assemble the two filter housing assemblies using (4x) M6 x 30 Hex Bolts (Fig. #10).
12. Install the vibration mount stud onto the airbox housing mounting tab located on the inner wing (Fig. #11).
13. On 4-wheel drive models, secure the front axle vent line to the EVAP hose with the provided cable tie (Fig. # 12).
14. Install the K&N air filter housing assembly into the vehicle. Secure with the (1x) M6 x 20 Hex Bolt through to the rubber vibration mount. Secure the lower mount with the original hex bolt / washer from the factory airbox (Fig. #13).
15. Install the straight coupler hose onto the throttle body and secure with (1x) #56 hose clamp (Fig. #14).
16. Install the hump coupler hose onto the round filter adapter and secure with (1x) #64 hose clamp (Fig. #15).
17. Install the (2x) 1/4"NPT - 5/8" Barb Vent Fittings into the K&N intake tube as shown (Fig. #16).
18. Carefully remove the Mass Air Sensor from the original airbox assembly and install it into the #420 Nylon Adapter using the original factory screws. Install the provided gasket onto the bottom of the adapter (Fig. #17).
19. Install the Mass Air Sensor assembly into the K&N intake tube using (2x) M6 x 16 Button head bolts & flat Washers. **NOTE: Be sure to install the sensor in the correct direction, the opening should be pointed towards the air filter (Fig. #18).**
20. Install the intake tube assembly into the couplers, adjust for best fit and then secure with the #56 & #64 hose clamps (Fig. #19).
21. Cut the provided 5/8" ID Hose in two, so they are slightly different lengths as shown. Then assemble the shorter hose to the 90 Degree Vent & the longer hose to 5/8" Straight Barb vent with the #10 Mini Hose clamps as shown (Fig. #20).
22. Connect these CCV hose assemblies to the factory CCV hoses and then push them onto the 5/8" barb fittings that were previously installed in the K&N Intake Tube & use a cable tie to secure the CCV elbow to the EVAP Hose (Fig. #21).
23. Reconnect the electrical harness plug to the MAS (Fig. #22)
24. Secure the MAS electrical harness using the cable ties supplied to the main wire harness.
24. Reinstall the engine cover and secure with the original factory hardware (Fig. #23).
25. Reconnect the negative battery cable. Double check to make sure everything is tight and properly positioned before starting the vehicle, Installation is now complete. (Fig. #24)

WARNING: Before starting the engine carry out a final fitment check of the K&N performance kit. It will be necessary for kits to be checked periodically for realignment, clearance and tightening of all connections. Failure to follow the instructions or proper maintenance may void the warranty.

FILTER MAINTENANCE: K&N suggests checking the filter periodically for excessive dirt build-up. When the element becomes covered in dirt (or once a year), service it according to the instructions on the service kit available from your K&N dealer, part number 99-5000EU

For the cleaning instructions please visit our website: www.knfilters.com/cleaning

For technical support contact our European technical team: eindhoven.tech@knfilters.com

For UK technical enquiries contact R&D department: uk.sales@knfilters.com or on **01925-636950**, Mon-Thu from 8:30 am to 5 pm.

Installation Instructions



Fig.#1



Fig.#2



Fig.#3



Fig.#4



Fig.#5



Fig.#6



Fig.#7



Fig.#8



Fig.#9



Fig.#10



Fig.#11



Fig.#12



Fig.#13



Fig.#14



Fig.#15



Fig.#16



Fig.#17



Fig.#18



Fig.#19



Fig.#20



Fig.#21



Fig.#22



Fig.#23



Fig.#24