



AIRCHARGER®

HIGH-FLOW INTAKE KITS

NOT LEGAL FOR SALE OR USE ON ANY POLLUTION CONTROLLED MOTOR VEHICLE IN CALIFORNIA OR STATES ADOPTING CALIFORNIA EMISSION PROCEDURES.
See knfilters.com for CARB status on each part for a specific vehicle

INSTALLATION INSTRUCTIONS

63-3119
CHEVROLET / GMC
2020-24 SILVERADO 2500 / 3500HD
2020-24 SIERRA 2500 / 3500HD
6.6L TURBO DIESEL

NOTE: This kit was not designed to fit vehicles with a body lift.

TOOLS NEEDED:

- Flat Blade Screw Driver
- 4mm Allen Key
- 5mm Allen Key
- 10mm Wrench
- 10mm Socket
- Ratchet
- Extension
- Electrical Tape

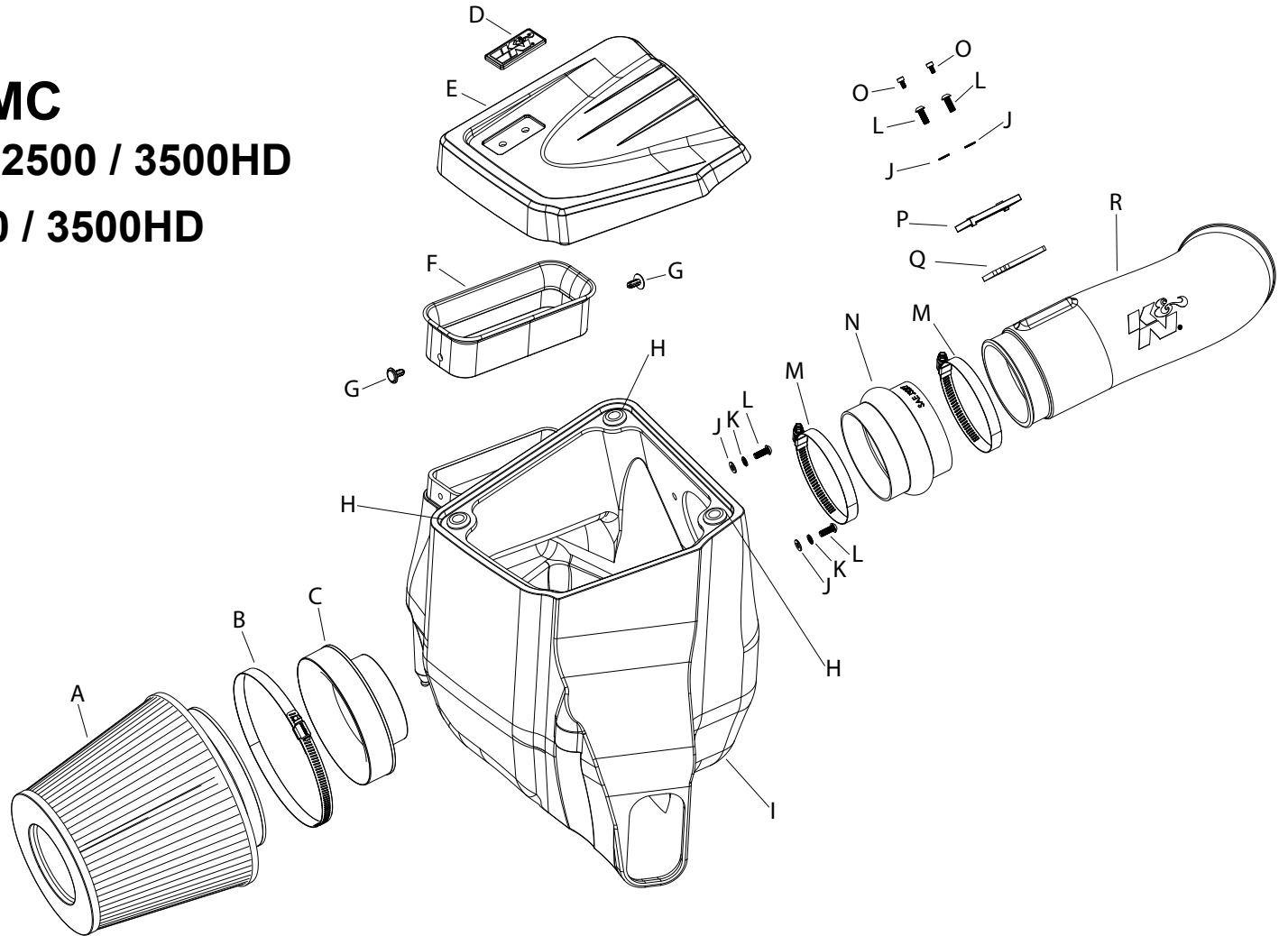

PARTS LIST:

Description	Qty.	Part #	Description	Qty.	Part #	Description	Qty.	Part #
A AIR FILTER	1	RU-5179	G RIVET; TUFLOK	2	345010	M HOSE CLAMP; #64 STAINLESS	2	08645
B HOSE CLAMP; #104	1	08697	H GROMMET; 1"OD, 1/2"ID, 1/2"	3	08064	N HOSE; HUMP 4"ID X 3"L	1	08418
C ADAPTOR; #454	1	27300	I AIRBOX; (OP)	1	087494	O BOLT; M4 - .7 X 8MM, ALNHD	2	07733
D BADGE; K&N LOGO	1	088096	J WASHER; 6MM FLAT	4	08269	P ADAPTOR; MAF SENSOR	1	21515-1
E LID; (OO)	1	087493	K WASHER, M6 SPLIT LOCK ZINC	2	1-3025	Q GASKET; 3/16" PORON	1	09069
F HOOD SEAL	1	084112	L BOLT; M6 X 1 X 16MM, BTNHD	4	07730	R TUBE; (OM)	1	087492

If you need any assistance please call 1-800-858-3333 to speak with a representative in our Customer Service Center before returning the product.

NOTE: FAILURE TO FOLLOW INSTALLATION INSTRUCTIONS AND NOT USING THE PROVIDED HARDWARE MAY DAMAGE THE INTAKE TUBE, THROTTLE BODY AND ENGINE.

TO START:

1. Turn off the ignition and disconnect the negative battery cable.
NOTE: Disconnecting the negative battery cable erases pre-programmed electronic memories. Write down all memory settings before disconnecting the negative battery cable. Some radios will require an anti-theft code to be entered after the battery is reconnected. The anti-theft code is typically supplied with your owner's manual. In the event your vehicles anti-theft code cannot be recovered, contact an authorized dealership to obtain your vehicles anti-theft code.



2. Loosen the two hose clamps securing the factory intake hose and then remove the hose from the vehicle.



3. Disconnect the mass air sensor electrical connection. **NOTE: 2024 model year vehicles and later have a different mass air sensor, the connector lays flat as compared to the sensor pictured.**



4. Remove the nut that secures the air filter housing into the vehicle and then lift up and remove the air filter housing from the vehicle.



5. Using the provided push pins, install the fresh air intake hood seal onto the K&N air filter housing.



6. Install the three provided grommets into the K&N air filter housing as shown.



7. Set the K&N air filter housing into the vehicle so the studs protrude into the factory mounting grommets. Secure the K&N Air filter housing with the factory from step #4.



8. Set the K&N air filter into the filter housing.



9. Install the filter adapter into the filter housing and secure with the provided hardware.



10. Slide the K&N air filter onto the filter adapter and secure with the provided hose clamp.



11. Install the K&N badge onto the lid and then install the lid onto the air filter housing as shown.



12. Install the provided hump coupler onto the filter adapter and secure with the provided hose clamp.



13. Remove the mass air sensor from the factory air filter housing. Assemble the mass air sensor, adapter and gasket as shown. **NOTE: 2024 model year vehicles and later have a different mass air sensor, the connector lays flat as compared to the sensor pictured.**



14. Install the mass air sensor assembly into the K&N intake tube and secure with the provided hardware. Be sure to install the sensor in the correct direction as shown. **NOTE: 2024 model year vehicles and later have a different mass air sensor, the connector lays flat as compared to the sensor pictured.**



15. Install the K&N intake tube assembly into the coupler at the filter adapter and then into the factory coupler, adjust the tube for best fit and secure with the hose clamps.



16. On 2014 and later model year vehicles that the electrical connection lays flat, it will be necessary to cut the electrical tape that secures the MAF pigtail to the main harness. Then pull approximately two inches of the MAF pigtail harness out from the main harness and retape the harness covering. This will allow enough slack in the harness to allow connection.



17. Reconnect the mass air sensor electrical connection.



18. Reconnect the vehicle's negative battery cable. Double check to make sure everything is tight and properly positioned before starting the vehicle.

19. It will be necessary for all K&N® high flow intake systems to be checked periodically for realignment, clearance and tightening of all connections. Failure to follow the above instructions or proper maintenance may void warranty.

20. **K&N AIR FILTER MONITOR LIGHT:** Some vehicles are equipped with a "Air Filter Monitor" system that will send a message to the instrument cluster indicating that the air filter needs to be replaced. This system is calibrated for the OEM intake system and air filter and will not be accurate when K&N products are in use. Always refer to WWW.KNFILTERS.COM for K&N air filter service procedures. The "Air Filter Monitor" system must be disabled to prevent the monitor from setting on and causing a factory dealership visit to reset the system. Follow the "Air Filter Monitor" system procedure listed in the factory owners manual.

ROAD TESTING:

1. Start the engine with the transmission in neutral or park, and the parking brake engaged. Listen for air leaks or odd noises. For air leaks secure hoses and connections. For odd noises, find cause and repair before proceeding. This kit will function identically to the factory system except for being louder and much more responsive.

2. Test drive the vehicle. Listen for odd noises or rattles and fix as necessary.

3. If road test is fine, you can now enjoy the added power and performance from your kit.

4. K&N Engineering, Inc., requires cleaning the intake system's air filter element every 100,000 miles. When used in dusty or off-road environments, our filters will require cleaning more often. We recommend that you visually inspect your filter once every 25,000 miles to determine if the screen is still visible. When the screen is no longer visible some place on the filter element, it is time to clean it. To clean and re-oil, purchase our filter Recharger® service kit, part number 99-5050 or 99-5000 and follow the easy instructions.

NOT LEGAL FOR SALE OR USE ON ANY POLLUTION CONTROLLED MOTOR VEHICLE IN CALIFORNIA OR STATES ADOPTING CALIFORNIA EMISSION PROCEDURES.

See knfilters.com for CARB status on each part for a specific vehicle