

# INSTALLATION INSTRUCTIONS

**69-1506TS**  
**HONDA**  
**2018-22 Accord**  
**L4-2.0L**

**TOOLS NEEDED:**

- Phillips screw driver
- Flat blade screw driver
- 3mm allen ratchet
- Extension
- 10mm socket
- 10mm wrench

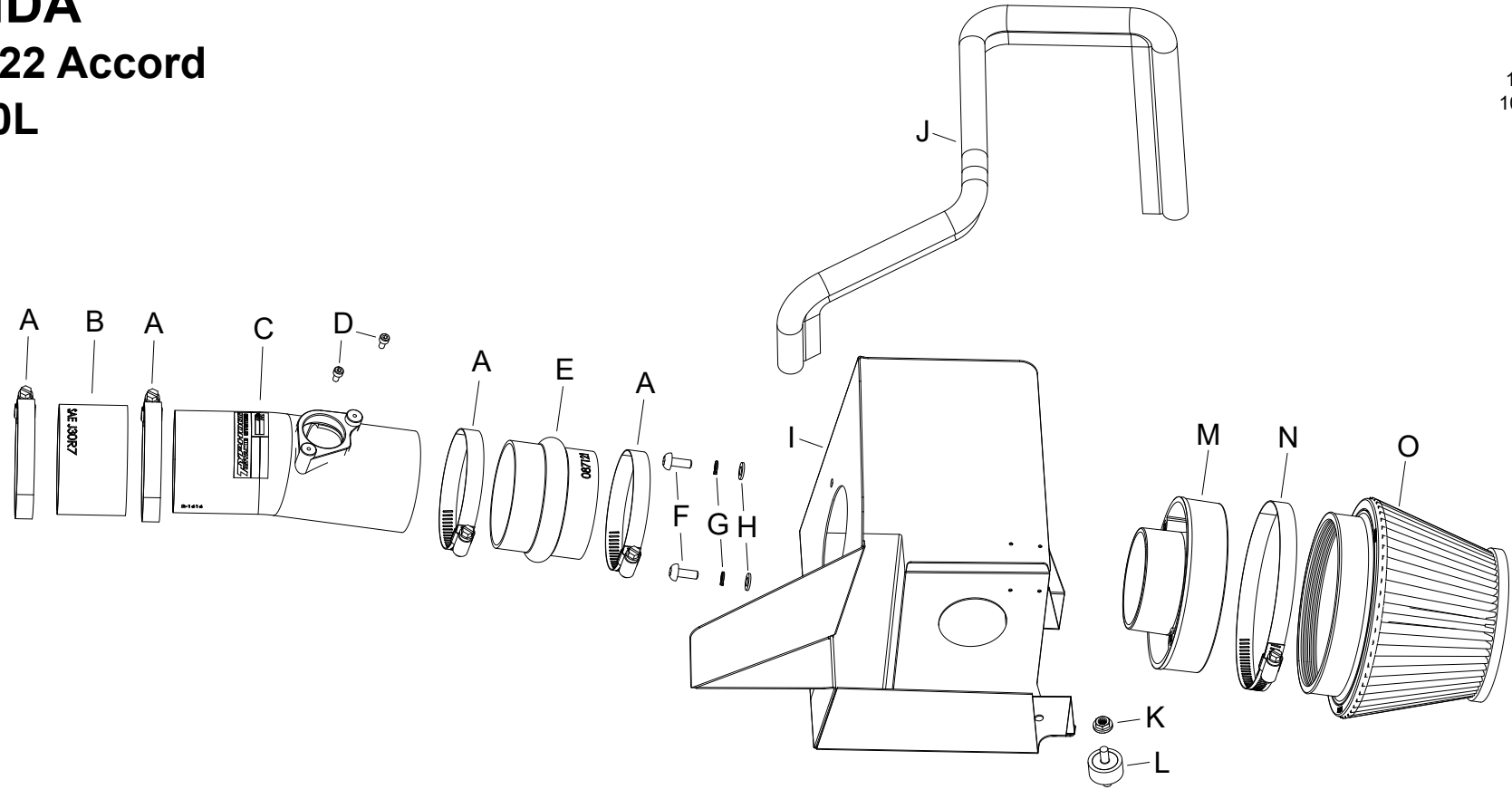

**PARTS LIST:**

Description	Qty.	Part #	Description	Qty.	Part #	Description	Qty.	Part #
A HOSE CLAMP #48	4	08601	F BOLT; M6 X 1 X 16MM	2	07730	K NUT; M6, SERRATED	1	KIT20WFCZ060
B HOSE; 3"ID X 2"L	1	08711	G WASHER, M6 SPLIT LOCK ZINC	2	1-3025	L STUD; M6-1.00 M/M, RUBBER	1	07027
C INTAKE TUBE; (AL)	1	2-1616S	H WASHER; 6MM FLAT	2	08269	M ADAPTER; FILTER, 3.0"OD	1	21569
D BOLT; M4 - .7 X 8MM	2	07733	I HEAT SHIELD	1	073265	N HOSE CLAMP; #88	1	KITHS88
E HOSE; HUMP 3"ID X 2.5"L	1	087121	J EDGE TRIM; 30"L	1	102489A	O AIR FILTER	1	RU-5163XD

**If you need any assistance please call 1-800-858-3333 to speak with a representative in our Customer Service Center before returning the product.**

**NOTE: FAILURE TO FOLLOW INSTALLATION INSTRUCTIONS AND NOT USING THE PROVIDED HARDWARE MAY DAMAGE THE INTAKE TUBE, THROTTLE BODY AND ENGINE.**

**TO START:**

1. Turn off the ignition and disconnect the negative battery cable.  
**NOTE: Disconnecting the negative battery cable erases pre-programmed electronic memories. Write down all memory settings before disconnecting the negative battery cable. Some radios will require an anti-theft code to be entered after the battery is reconnected. The anti-theft code is typically supplied with your owner's manual. In the event your vehicles anti-theft code cannot be recovered, contact an authorized dealership to obtain your vehicles anti-theft code.**



2. Disconnect the mass air sensor electrical connection.



3. Loosen the hose clamp that secures the intake hose to the turbo inlet tube.



4. Remove the four push pins that secure the fresh air intake duct and then lift the fresh air intake duct out to remove it from the vehicle.

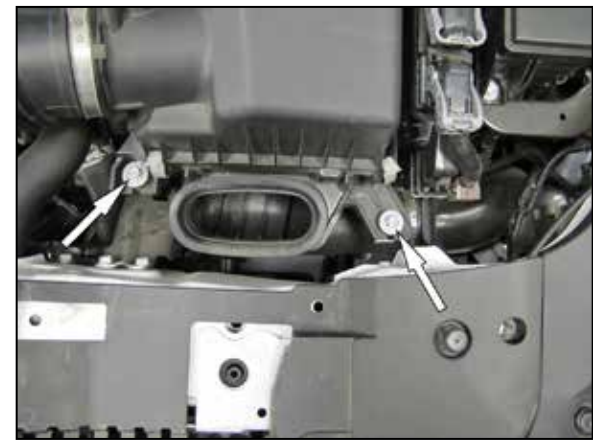

5. Remove the two bolts that secure the air filter housing to the inner fender and then remove the bolts from the vehicle.  
**NOTE: K&N Engineering, Inc., recommends that customers do not discard factory air intake.**



6. Install the provided edge trim onto the heat shield as shown.  
**NOTE: Some trimming of the edge trim will be necessary.**

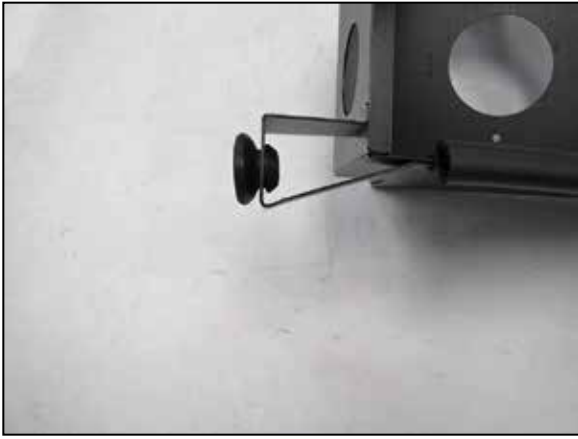

7. Remove the mounting grommet from the factory air filter housing and install it into the K&N® heat shield as shown.



8. Install the provided filter adapter into the heat shield and secure with the provided hardware.



9. Install the provided rubber mounted stud onto the factory air filter housing mounting location.



10. Install the heat shield and secure with the provided hardware.



11. Install the provided coupling hose (087121) onto the filter adapter and secure with the provided hose clamp.



12. Install the provided coupling hose (08711) onto the intake tube so that it slides all the way on. Do not secure the hose now.



13. Remove the mass air sensor from the factory air filter housing and then install it into the K&N® intake tube and secure with the provided hardware.



14. Install the K&N® intake tube into the coupler at the filter adapter and align with the turbo inlet pipe, slide the coupler back onto the turbo inlet pipe and adjust the tube for best fit. Secure the intake tube with the provided hose clamps.



15. Install the K&N® air filter onto the filter adapter and secure with the provided hose clamp.



16. Reconnect the mass air sensor electrical connection.



17. Reconnect the vehicle's negative battery cable. Double check to make sure everything is tight and properly positioned before starting the vehicle.

18. It will be necessary for all K&N® high flow intake systems to be checked periodically for realignment, clearance and tightening of all connections. Failure to follow the above instructions or proper maintenance may void warranty.

#### ROAD TESTING:

1. Start the engine with the transmission in neutral or park, and the parking brake engaged. Listen for air leaks or odd noises. For air leaks secure hoses and connections. For odd noises, find cause and repair before proceeding. This kit will function identically to the factory system except for being louder and much more responsive.

2. Test drive the vehicle. Listen for odd noises or rattles and fix as necessary.

3. If road test is fine, you can now enjoy the added power and performance from your kit.

4. K&N Engineering, Inc., requires cleaning the intake system's air filter element every 100,000 miles. When used in dusty or off-road environments, our filters will require cleaning more often. We recommend that you visually inspect your filter once every 25,000 miles to determine if the screen is still visible. When the screen is no longer visible some place on the filter element, it is time to clean it. To clean and re-oil, purchase our filter Recharger® service kit, part number 99-5050 or 99-5000 and follow the easy instructions.

**NOT LEGAL FOR SALE OR USE ON ANY POLLUTION CONTROLLED MOTOR VEHICLE IN CALIFORNIA OR STATES ADOPTING CALIFORNIA EMISSION PROCEDURES.**

See [knfilters.com](http://knfilters.com) for CARB status on each part for a specific vehicle