

INSTALLATION INSTRUCTIONS

69-4535TP
CHEVROLET
2016-24 Camaro
V6-3.6L

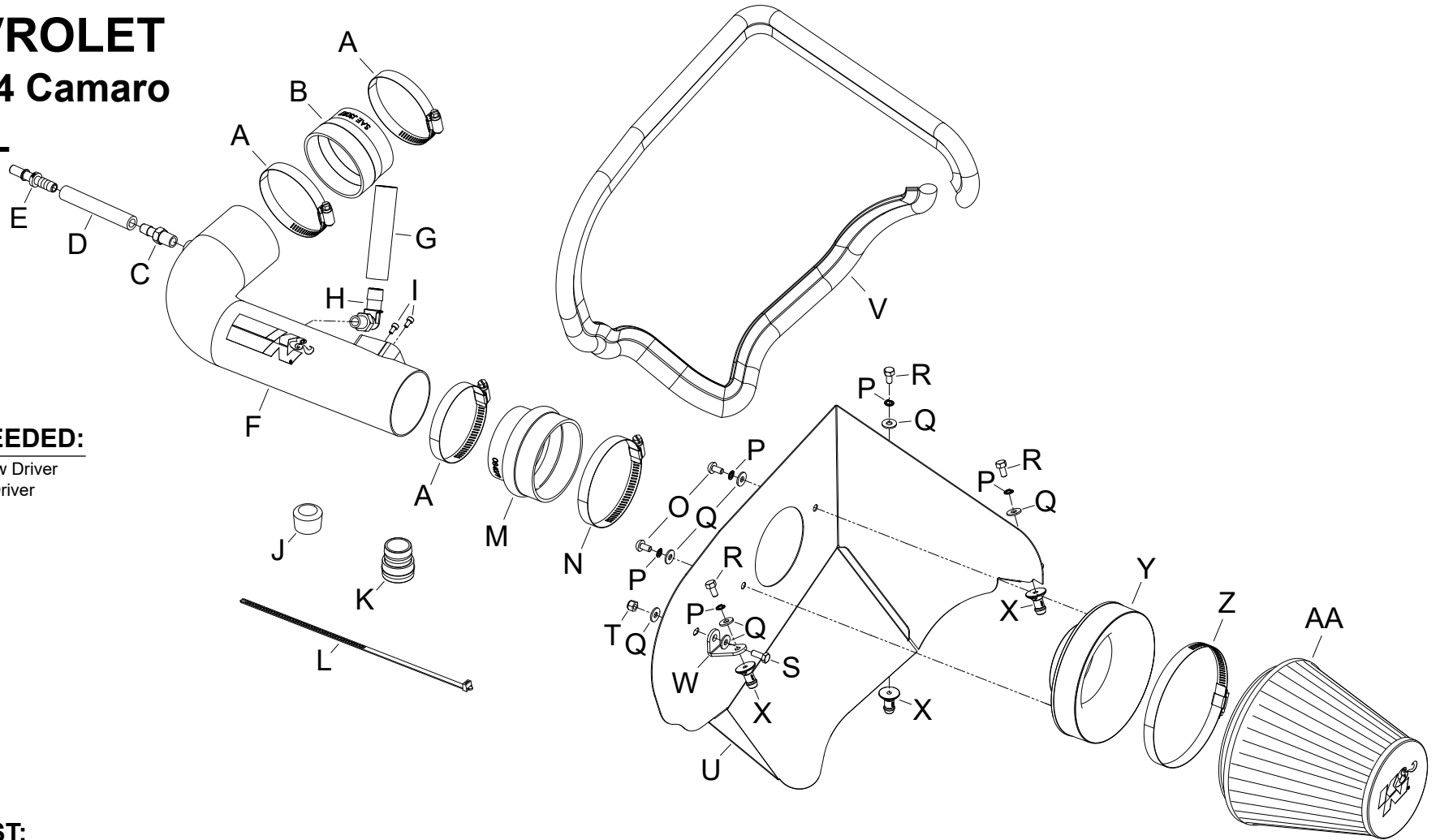

TOOLS NEEDED:

- Flat Blade Screw Driver
- Phillips Screw Driver
- Ratchet
- Extension
- 10mm Socket
- 10mm Wrench
- t20 Torx
- t30 Torx
- 3mm Allen Key
- 4mm Allen Key

PARTS LIST:

Description	Qty.	Part #	Description	Qty.	Part #	Description	Qty.	Part #
A HOSE CLAMP #48	3	08601	J CAPPLUG; 15/16" ID, 3/4" L, BLK	1	08246	S BOLT; M6-1 X 16MM, HEX	1	07812
B HOSE; 3.125"ID TO 3"ID X 2"L	1	084031	K FITTING; 1-1/8"OD QUICK	1	088012	T NUT; 6MM NYLOCK, HEXHD	1	07512
C VENT; STRT, 3/8"HOSE, 1/4"NPT	1	08047	L CABLE TIES; 11" BLACK	1	21590	U HEAT SHIELD	1	073231
D HOSE; 3/8"ID X 4"L	1	5-1004	M HOSE; HUMP 3.5" TO 3"ID	1	084079	V EDGE TRIM; (61"L)	1	102492
E VENT; STRT, 3/8" BARB	1	82631	N HOSE CLAMP #56	1	08620	W BRACKET; "L"	1	064340A
F INTAKE TUBE; (AL)	1	27666P	O BOLT; M6 - 1 X 12MM, BTNHD	2	07794	X MOUNT, PLASTIC AIRBOX	3	8-186-1
G HOSE; 5/8" ID X 4" L	1	08244	P WASHER, M6 SPLIT LOCK ZINC	5	1-3025	Y ADAPTER; UNIVERSAL, 6"	1	21512-1
H FITTING; VENT, 1/4"NPT	1	08525	Q WASHER; 6MM FLAT	7	08269	Z HOSE CLAMP #104	1	08697
I BOLT; M4-.7 X 8MM, ALNHD	2	07733	R BOLT; M6 X 1 X 12MM, HEXHD	3	07727	AA AIR FILTER	1	RU-5107

If you need any assistance please call 1-800-858-3333 to speak with a representative in our Customer Service Center before returning the product.

NOTE: FAILURE TO FOLLOW INSTALLATION INSTRUCTIONS AND NOT USING THE PROVIDED HARDWARE MAY DAMAGE THE INTAKE TUBE, THROTTLE BODY AND ENGINE.

TO START:

1. Turn off the ignition and disconnect the negative battery cable.

NOTE: Disconnecting the negative battery cable erases pre-programmed electronic memories. Write down all memory settings before disconnecting the negative battery cable. Some radios will require an anti-theft code to be entered after the battery is reconnected. The anti-theft code is typically supplied with your owner's manual. In the event your vehicles anti-theft code cannot be recovered, contact an authorized dealership to obtain your vehicles anti-theft code.



2. Remove the bolt that secures the decorative engine cover, remove the oil cap and then remove the decorative engine cover. Reinstall the oil cap.



3. Release the locking tap and then disconnect the EVAP vent line quick disconnect fitting from the factory intake tube.



4. Release the sound tube quick disconnect fitting and disconnect the sound tube from the factory intake tube.



5. Loosen the three hose clamps that secure the intake tube and crank case vent tube then remove the tune from the vehicle



6. Release the three flexible clamps that secure the sound tube and disconnect the sound drum from the rear sound tube then remove the sound tube assembly.



7. Install the provided capplug onto the quick disconnect union fitting provided.



8. Install the capplug assembly into the remaining sound tube and secure with the provided tie wrap.

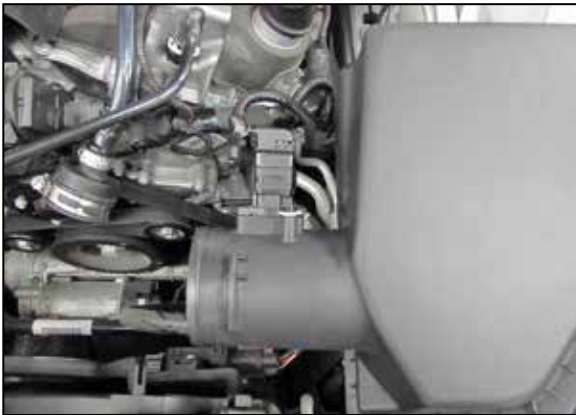

9. Disconnect the mass air sensor electrical connection.



10. Lift up and remove the factory air filter housing assembly.
NOTE: K&N Engineering, Inc., recommends that customers do not discard factory air intake.



11. Remove the factory crank case vent coupler from the crank case vent tube.
NOTE: Use twisting/pulling motions to slip the coupler off the tube, it is not necessary to cut the factory clamp.

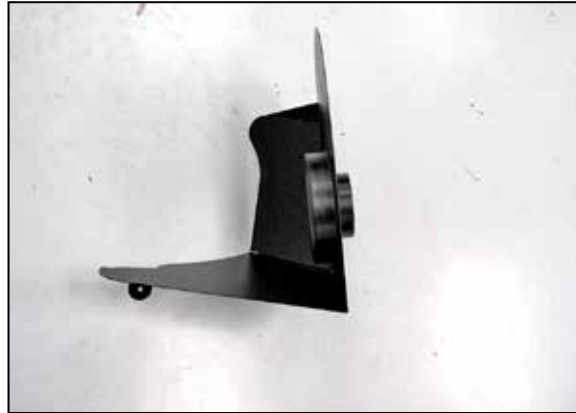

12. Install the filter adapter into the heat shield and secure with the provided hardware.



13. Install the provided edge trim onto the heat shield as shown.
NOTE: Some trimming of the edge trim will be necessary.

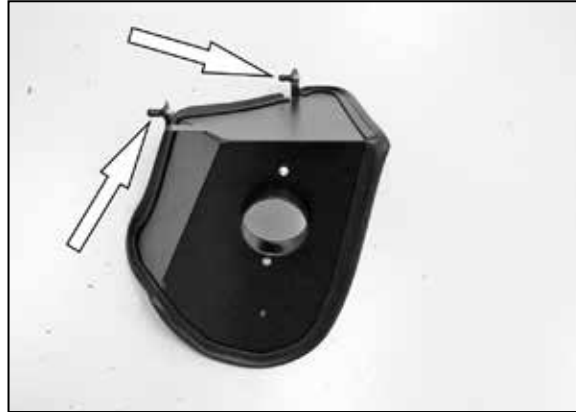

14. Install the two provided mounting posts onto the heat shield using the provided hardware.



15. Install remaining mounting post onto the long leg of the provided bracket (064340) and then install the assembly onto the heat shield using the provided hardware.



16. Install the heat shield assembly onto the factory air filter housing mounting grommets.



17. Install the provided coupler (084031) onto the throttle body and secure with the provided hose clamp.



18. Install the provided hump coupler (084079) onto the filter adapter and secure with the provided hose clamp.



19. Assemble the provided EVAP fittings and hose as shown.



20. Install the EVAP hose assembly onto the K&N® intake tube as shown.



21. Install the 90° crank case vent fitting into the K&N® intake tube as shown.
NOTE: Plastic NPT fittings are easy to cross thread. Install the vent fitting "hand" tight, then turn it two complete turns with a wrench.



22. Remove the mass air sensor from the factory air filter housing.



23. Install the mass air assembly into the K&N® intake tube as shown.



24. Install the K&N® intake tube assembly into the coupler at the filter adapter and then into the coupler on the throttle body, adjust the tube for best fit and then secure with the provided hose clamps.



25. Connect the K&N® EVAP quick disconnect fitting into the factory fitting.



26. Install the provided crank case vent hose onto the factory vent hose and K&N® fitting.



27. Reconnect the mass air sensor electrical connection.



28. Install the K&N® air filter and secure with the provided hose clamp.

NOTE: Drycharger® air filter wrap; part # RC-5107DK is available to purchase separately. To learn more about Drycharger® filter wraps or look up color availability please visit <http://www.knfilters.com>®.



29. Reinstall the decorative engine cover and secure with the factory bolt and oil cap.



30. Reconnect the vehicle's negative battery cable. Double check to make sure everything is tight and properly positioned before starting the vehicle.

31. It will be necessary for all K&N® high flow intake systems to be checked periodically for realignment, clearance and tightening of all connections. Failure to follow the above instructions or proper maintenance may void warranty.

ROAD TESTING:

1. Start the engine with the transmission in neutral or park, and the parking brake engaged. Listen for air leaks or odd noises. For air leaks secure hoses and connections. For odd noises, find cause and repair before proceeding. This kit will function identically to the factory system except for being louder and much more responsive.

2. Test drive the vehicle. Listen for odd noises or rattles and fix as necessary.

3. If road test is fine, you can now enjoy the added power and performance from your kit.

4. K&N Engineering, Inc., requires cleaning the intake system's air filter element every 100,000 miles. When used in dusty or off-road environments, our filters will require cleaning more often. We recommend that you visually inspect your filter once every 25,000 miles to determine if the screen is still visible. When the screen is no longer visible some place on the filter element, it is time to clean it. To clean and re-oil, purchase our filter Recharger® service kit, part number 99-5050 or 99-5000 and follow the easy instructions.

NOT LEGAL FOR SALE OR USE ON ANY POLLUTION CONTROLLED MOTOR VEHICLE IN CALIFORNIA OR STATES ADOPTING CALIFORNIA EMISSION PROCEDURES.

See knfilters.com for CARB status on each part for a specific vehicle