



# INSTALLATION INSTRUCTIONS

81-0816

JEEP

2018-2023 Wrangler/Gladiator 3.6L

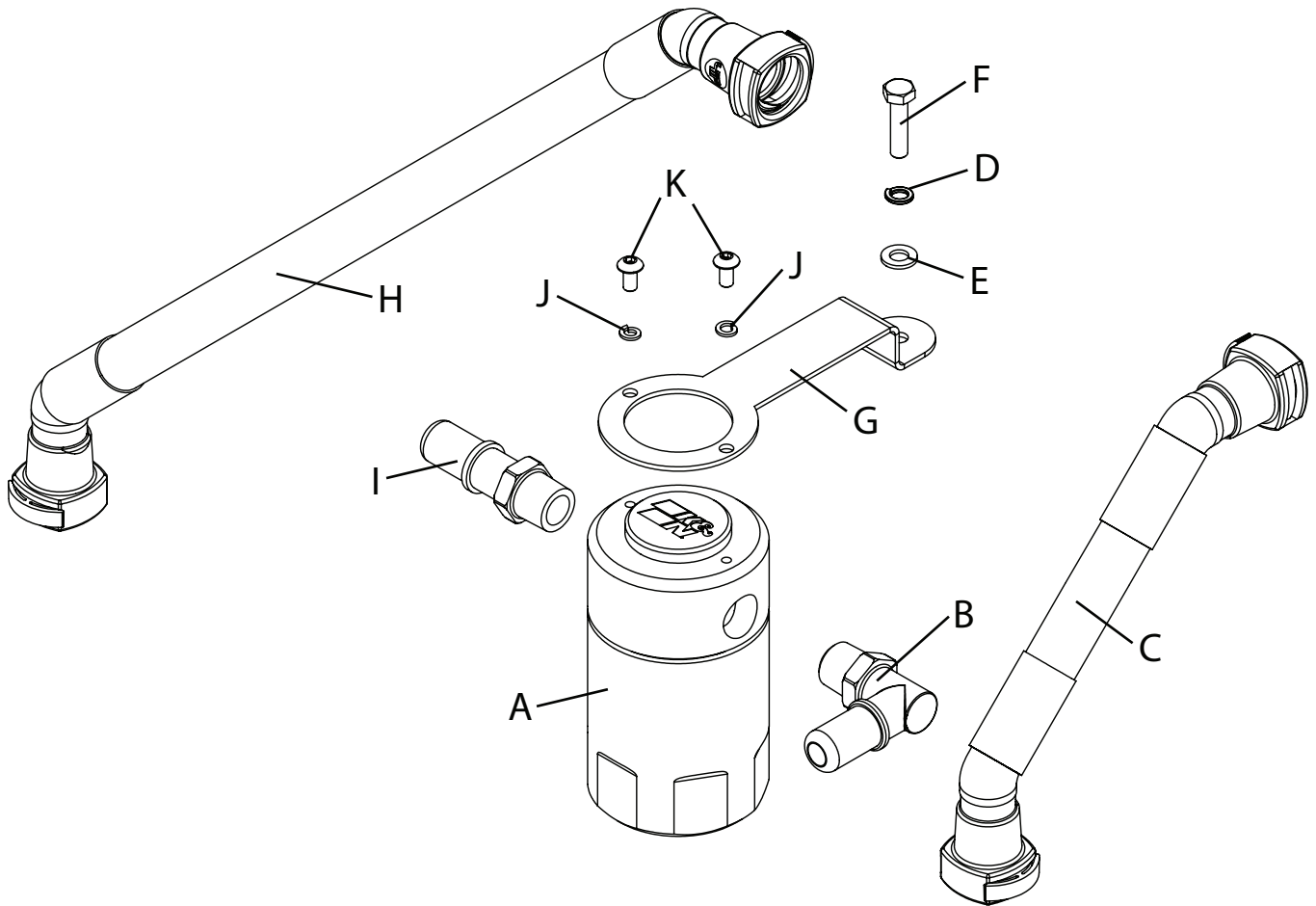

## PARTS LIST:

	Description	Qty.	Part #
A	CATCH CAN; 2.5"OD X 4.5"H	1	85-6860
B	QUICK RELEASE; 3/8" NPT 90°	1	082634
C	HOSE; 1/2"ID X 37"L	1	084174
D	M6 SPLIT LOCK WASHER	1	AEM-1-3025
E	M6 WASHER	1	08269
F	M6 BOLT X 1.00	1	07858
G	BRACKET	1	010237
H	HOSE; 1/2"ID X 17"L	1	084175
I	QUICK RELEASE; 3/8" NPT	1	82637
J	18-8 SPLIT LOCK WASHER	2	92146A618
K	BUTTON HEAD CAP SCREW	2	91255A192

## TOOLS NEEDED:

- 2.5mm Allen key
- Ratchet
- 10mm Socket
- 13/16" Wrench

1. Verify you have all the parts included in the kit.



2. Remove engine cover by removing the two 10mm bolts

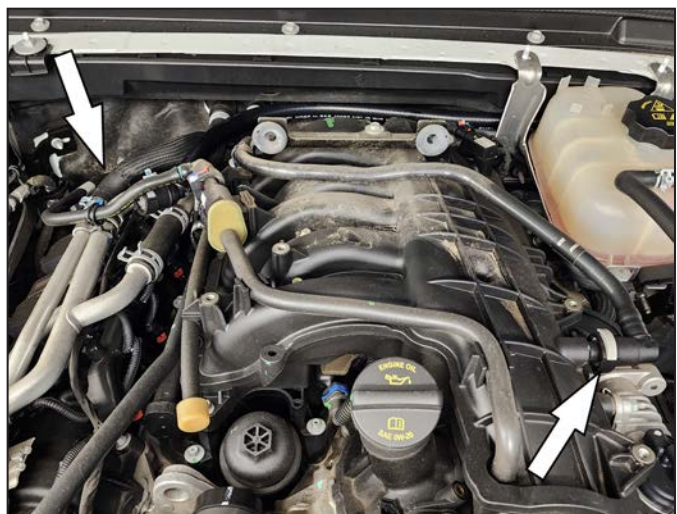

3. Remove factory PCV line by depressing the button and removing it from the PCV valve and intake manifold



4. Remove nuts from coolant reservoir and pull up and off studs for additional clearance routing the hoses

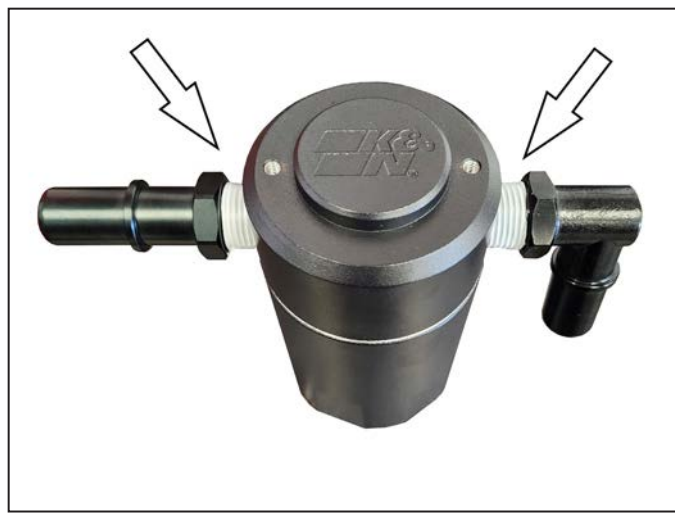

5. Assemble the quick disconnect fittings to the top of the air/oil separator as shown. It is required to use Teflon tape on the fittings to ensure a proper seal. **NOTE: DO NOT over-tighten fittings in top of oil separator**

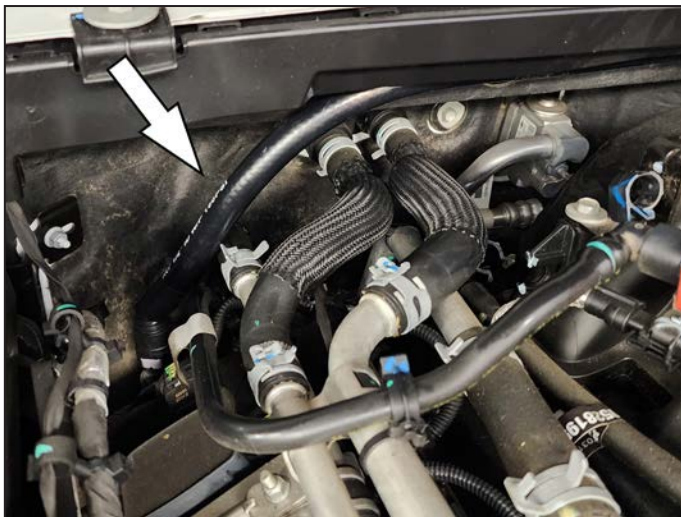

6. Route the long hose along the back of the firewall behind the coolant reservoir. Connect to the valve cover and remount the coolant reservoir

7. Connect the short hose to the intake manifold and route under the brake fluid reservoir



8. Install the bracket using the supplied 10mm bolt, lock washer and flat washer in the empty threaded hole on the fender shown. Mount the long hose from the valve cover to the straight fitting of the canister. Mount the short hose from the intake manifold to the 90 degree connection on the canister. **NOTE: Lightly coat the O-Ring with oil to insert easily**

9. Reinstall engine cover

10. We recommend to check the oil separator every 10,000 miles or 1 year (sooner if vehicle is driven in harsher conditions such as towing or off-road)