



Elite Series Fender Flares

**For proper installation and best possible fit, please read all instructions BEFORE you begin.
For technical assistance or to obtain missing parts, please call Customer Relations at 1-800-241-7219.**

Important Safety Information



- CAUTION - Before driving, ensure that the fender flare is properly secured to vehicle.
- Do not use automatic "brush-style" car washes.
- Do not use cleaning solvents of any kind.
- Periodically check all components for tightness.

Contents

NOTE: Actual product may vary from illustration.



Driver side front flare



Passenger side front flare



Driver side Side Step



Passenger side Side Step



Driver side rear flare



Passenger side rear flare



Bolts (34)



Spacer(28)



Washer (28)



Nuts (28)



Rubber Seal

Tools Required

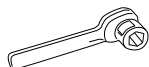

Socket Wrench

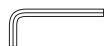

Allen Wrench

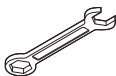

Wrench or Adjustable Wrench



Razor Blade



Needle Nose Pliers



Safety glasses

Preparation Before Painting / Installation

Custom Paint Job (Optional)

Please test fit all the flares first to ensure you have the correct flares for your vehicle. We are not responsible for any costs you may incur if you did not confirm the flares before having it painted. We recommend hiring professionals to custom paint the products. It is also ideal to have the painting done prior to the installation to eliminate any over-spraying issues.

Cleaning the vehicle

Make sure to wash your vehicle, especially the area the fender flares will be mounted to including the inner fender lip after removing the original fender flare and splash guard assembly. Any dirt or debris that has not been cleaned or removed can potentially cause the improper fitment of the fender flare. If you are covering existing rust, we recommend sanding down the rust and primer over to prevent further deterioration of the metal in the fender. Make sure the vehicle is dry before the installation. The fender flares come ready to be installed, however if you need to clean them, please use a mild detergent to wash and then dry completely.

Professional installation (optional)

While every effort has been made to make this installation as simple as possible, professional installation may be advisable in some instances.

Installation Steps NOTE: Actual application may vary slightly from illustrations.

Front Flares

Disengage side marker bulb assembly from side marker lamp housing. Remove mounting nut and remove side marker lamp housing from factory fender flare. Retain mounting nut.

1

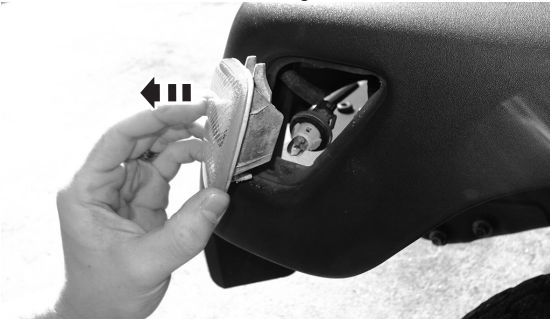

Remove (8) mounting bolts from factory fender flare.

2



Remove front fender flare, and clean fender mounting area.

3



Loosen (3) bolts on factory installed side step, and remove side step. Remove remaining bolts from fender, and clean fender.

4



Use a razor blade to cut and install rubber seal on the new fender flare edge, that will mount against fender.



Place a bolt through a hole in the new fender flare, and place a black spacer on the bolt on the opposite side of the fender flare to retain it in place. Repeat for remaining holes.

5



bolt through this side

6

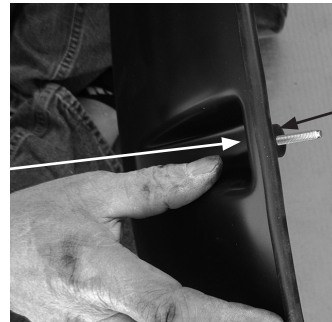

Align new fender flare with holes in fender. NOTE: The new fender flare utilizes (6) holes only.

7



Reach behind the flare and place a washer and nut on each bolt to secure fender flare to fender. DO NOT FULLY TIGHTEN AT THIS TIME.

8



Installation Steps

NOTE: Actual application may vary slightly from illustrations.

With fender flare in final position, tighten all bolts and nuts using hand tools only. **DO NOT OVER TIGHTEN.**

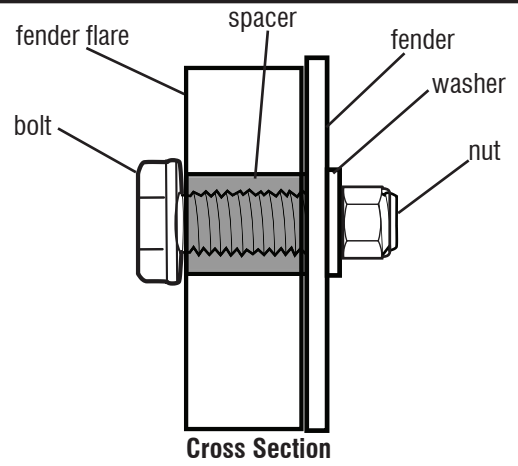

9

Reinstall side marker lamp and bulb assembly.



10



Slide (3) bolts through the new Side Step and thread into mounting holes in fender.



11

With the Side Step in final position, tighten all (3) bolts using hand tools only. **DO NOT OVER TIGHTEN.**



12

Rear Flares

Remove (8) mounting bolts from rear factory fender flare.



13

Remove rear fender flare, and clean fender mounting area.



14

Disengage (2) rubber mounting pins from rear splash shield in order to gain access behind fender.



15

Installation Steps

NOTE: Actual application may vary slightly from illustrations.



Use a razor blade to cut and install rubber trim on the new fender flare edge, that will mount against fender.



16



Place a bolt through a hole in the new fender flare, and place a black spacer on the bolt on the opposite side of the fender flare to retain it in place. Repeat for remaining holes.



bolt through this side

17

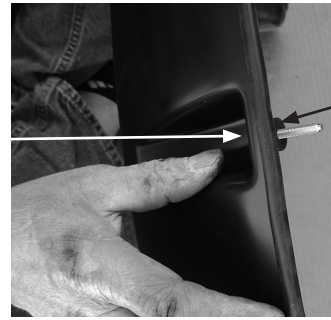

Align new fender flare with holes in fender.



18



Reach behind the flare and place a washer and nut on each bolt to secure fender flare to fender. **DO NOT FULLY TIGHTEN AT THIS TIME.**



19



With fender flare in final position, tighten all bolts and nuts using hand tools only. Reattach splash guard that was loosened in **Step 15**. **DO NOT OVER TIGHTEN.**



20

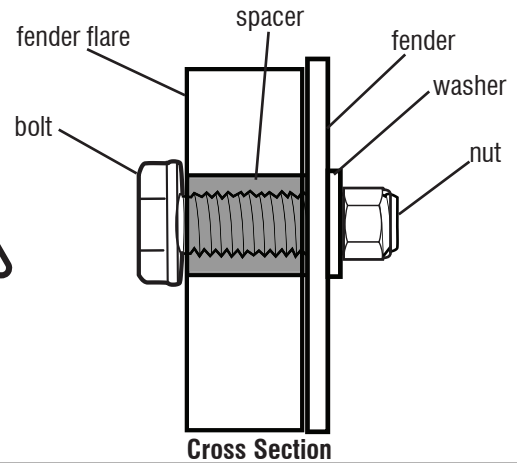

Repeat **Steps 1 thru 20** for opposite side.

Care and Cleaning

- Lund fender flares are built to last; any detergent you use to wash your vehicle is sufficient to clean the flares. Do not use any harsh abrasive detergents.

Congratulations!

You have purchased one of the many quality Lund[®] branded products offered by Lund International, Inc. We take the utmost pride in our products and want you to enjoy years of satisfaction from your investment. We have made every effort to ensure that your product is top quality in terms of fit, durability, finish and ease of installation.

LUND[®]

Lund International

800-241-7219 • Visit us at lundinternational.com

© 2014 Lund International, Inc. All rights reserved.

Lund[®] and the Lund[®] logo are trademarks of Lund International, Inc.



LUND[®]

Élargisseurs d'aile de la série Elite

Veillez lire l'ensemble des instructions AVANT d'utiliser le produit afin de garantir une installation correcte et un ajustement optimal. Pour obtenir une assistance technique ou demander des pièces manquantes, veuillez appeler le service clientèle au 1-800 241-7219.

Consignes de sécurité importantes



- **PRÉCAUTION** - Avant de conduire, vérifier que l'élargisseur d'aile est bien fixé au véhicule.
- Ne pas utiliser les postes de lavage automatiques à brosses.
- Ne pas utiliser de solvants lors du lavage.
- Vérifier régulièrement que les composants sont bien fixés.

Contenu

REMARQUE : Le produit réel peut différer du modèle illustré.



Élargisseur avant
côté conducteur



Élargisseur avant
côté passager



Marche latérale
côté conducteur



Marche latérale
côté passager



Élargisseur arrière
côté conducteur



Élargisseur arrière
côté passager



Écrous (34)



Entretoise (28)



Rondelle (28)



Écrous (28)



Joint en caoutchouc

Outils nécessaires

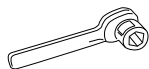

Clé à douille



Clé Allen

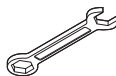

Clé ou
clé à molette



Lame de rasoir



Pince à becs
pointus



Lunettes de protection

Préparation avant la peinture/installation

Travail de peinture sur mesure (facultatif)

Vérifiez d'abord tous les élargisseurs pour vous assurer que vous avez les élargisseurs appropriés pour votre véhicule. Nous n'assumons aucun frais engendré si vous n'avez pas confirmé les élargisseurs avant de les peindre. Nous recommandons de faire appel à des professionnels pour peindre les produits sur mesure. Il est également idéal de réaliser le travail de peinture avant l'installation pour éliminer tout problème de pulvérisation.

Nettoyage du véhicule

Assurez-vous de nettoyer votre véhicule, en particulier la zone sur laquelle les élargisseurs d'aile seront montés, notamment le rebord de l'aile interne après avoir retiré l'élargisseur d'aile et l'ensemble du pare-boue d'origine. Tous les débris ou les poussières qui n'ont pas été nettoyé(s) ou éliminé(s) peuvent éventuellement entraîner un montage inapproprié de l'élargisseur d'aile. Si vous vous occupez de la rouille existante, nous recommandons de poncer la rouille et d'appliquer une couche d'apprêt pour éviter toute dégradation du métal de l'aile. Assurez-vous que le véhicule est sec avant l'installation. Les élargisseurs d'aile sont prêts à être installés, cependant si vous devez les nettoyer, veuillez utiliser un détergent doux pour les laver et les sécher entièrement.

Installation professionnelle (facultatif)

Bien que nous nous soyons appliqués à rendre cette installation aussi simple que possible, une installation professionnelle peut être recommandée dans certains cas.

Étapes de l'installation **REMARQUE** : l'installation réelle peut différer légèrement des illustrations.

Élargisseurs avant

Désengagez l'ensemble de l'ampoule du feu de gabarit du logement de l'ampoule du feu de gabarit. Retirez l'écrou de montage et le logement du feu de gabarit de l'élargisseur d'aile

monté d'origine. Retenir l'écrou de montage.



1

Retirez les (8) boulons de fixation de l'élargisseur d'aile d'origine.



2

Retirez l'élargisseur d'aile avant et nettoyez la zone de montage de l'aile.



3

Desserrez les (3) boulons de la marche latérale installée en usine et retirez la marche latérale. Retirez les boulons restants de l'aile et nettoyez l'aile.



4



Utilisez une lame de rasoir pour couper et installer le joint en caoutchouc sur le bord du nouvel élargisseur d'aile qui sera monté contre l'aile.



5



Placez un boulon dans un trou du nouvel élargisseur d'aile et placez une entretoise noire sur le boulon du côté opposé de l'élargisseur d'aile pour le maintenir en place. Répétez l'opération pour les trous restants.



boulon par ce côté

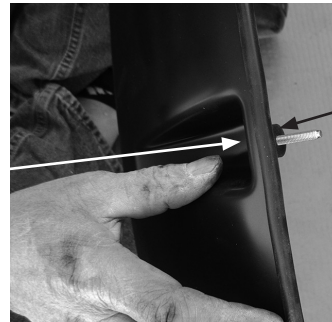

6

Alignez le nouvel élargisseur d'aile avec les trous de l'aile.
REMARQUE : Le nouvel élargisseur d'aile utilise (6) trous seulement.



7



Accédez à l'arrière de l'aile et placez une rondelle et un écrou sur chaque boulon pour fixer l'élargisseur d'aile à l'aile. **NE PAS SERRER À FOND MAINTENANT.**



8

Étapes de l'installation **REMARQUE** : l'installation réelle peut différer légèrement des illustrations.

Avec l'élargisseur d'aile en position finale, serrez tous les boulons et les écrous à l'aide d'outils à main uniquement. **NE PAS SERRER À L'EXCÈS.**

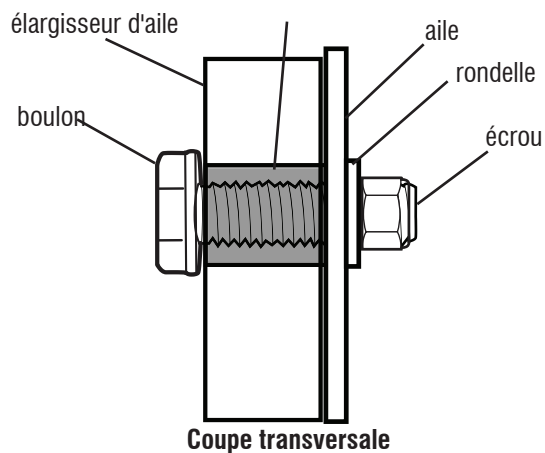

9

Réinstallez l'ensemble de l'ampoule et du feu de gabarit.



10



Faites glisser les (3) boulons à travers la nouvelle marche latérale et insérez-les dans les trous de fixation de l'aile.



11

Avec la marche latérale en position finale, serrez tous les boulons (3) à l'aide d'outils à main uniquement. **NE PAS SERRER À L'EXCÈS.**



12

Élargisseurs arrière

Retirez les (8) boulons de fixation de l'élargisseur d'aile arrière d'origine.



13

Retirez l'élargisseur d'aile arrière et nettoyez la zone de montage de l'aile.

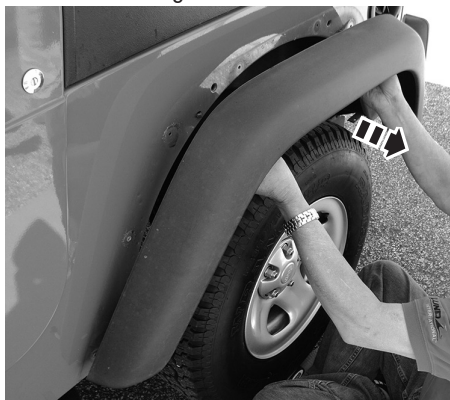

14

Désengagez les (2) goupilles de fixation en caoutchouc du pare-boue arrière afin d'accéder à l'arrière de l'aile.



15

Étapes de l'installation **REMARQUE** : l'installation réelle peut différer légèrement des illustrations.



Utilisez une lame de rasoir pour couper et installer la garniture en caoutchouc sur le bord du nouvel élargisseur d'aile qui sera monté contre l'aile.



16



Placez un boulon dans un trou du nouvel élargisseur d'aile et placez une entretoise noire sur le boulon du côté opposé de l'élargisseur d'aile pour le maintenir en place. Répétez l'opération pour les trous restants.



boulon par ce côté

17

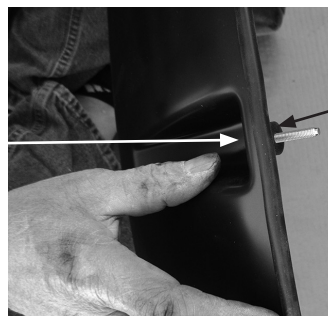

entretoise de ce côté

Alignez le nouvel élargisseur d'aile avec les trous de l'aile.



18



19

Accédez à l'arrière de l'aile et placez une rondelle et un écrou sur chaque boulon pour fixer l'élargisseur d'aile à l'aile. **NE PAS SERRER À FOND MAINTENANT.**

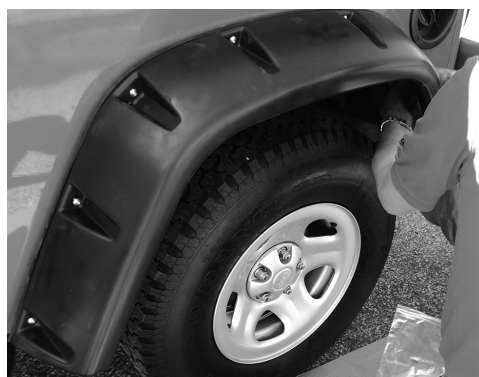

Avec l'élargisseur d'aile en position finale, serrez tous les boulons et les écrous à l'aide d'outils à main uniquement. Attachez de nouveau le pare-boue que vous avez desserré à l'étape 15. **NE PAS SERRER À L'EXCÈS.**



20

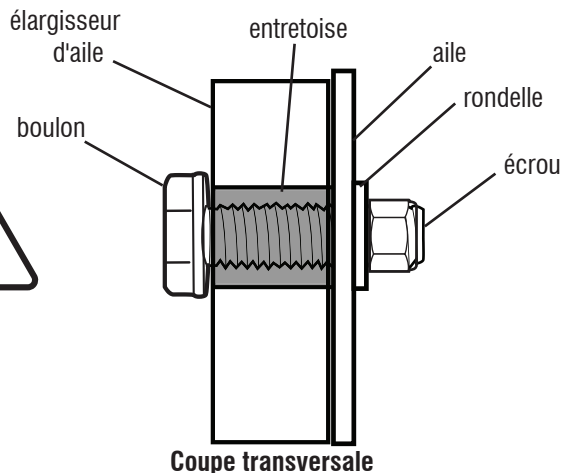

Répétez les **étapes 1 à 20** pour le côté opposé.

Entretien et nettoyage

- Les élargisseurs d'aile Lund sont conçus pour durer; tout détergent que vous utilisez pour laver votre véhicule est suffisant pour nettoyer les élargisseurs. Ne pas utiliser de détergents abrasifs durs.

Félicitations!

Vous venez d'acheter un des nombreux produits de qualité de la marque Lund® fabriqués par Lund International, Inc. Nous sommes extrêmement fiers de la qualité de nos produits et nous espérons que vous profiterez de cet investissement de longues années durant. Nous nous efforçons d'offrir la meilleure qualité en termes d'ajustement, de finition, de durabilité et de facilité d'installation.

LUND®

Lund International

800-241-7219 • Visitez notre site Web lundinternational.com

© 2013 Lund International, Inc. Tous droits réservés.

Lund® et le logo Lund® sont des marques déposées de Lund International, Inc.





Extensiones de guardabarros Serie Elite

Para la instalación correcta y el mejor ajuste posible, lea las instrucciones ANTES de comenzar.
Para pedir asistencia técnica u obtener partes que falten, por favor llame a Atención al cliente al 1-800-241-7219.

Información importante sobre seguridad



- PRECAUCIÓN: Antes de conducir, asegúrese de que la extensión del guardabarros esté debidamente asegurada al vehículo.
- No lave su auto en lavaderos automáticos que utilicen cepillos.
- No use ningún tipo de solvente de limpieza.
- Compruebe periódicamente que todos los componentes estén ajustados.

Contenido **NOTA:** El producto real tal vez no sea igual a la ilustración.



Extensión delantera del lado del conductor



Extensión delantera del lado del pasajero

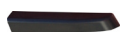

Escalón lateral del lado del conductor



Escalón lateral del lado del pasajero



Extensión posterior del lado del conductor



Extensión posterior del lado del pasajero



Tornillos (34)



Separadores (28)



Arandelas (28)



Tuercas (28)



Sello de caucho

Herramientas necesarias

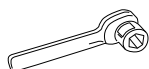

Llave de cubo



Llave Allen

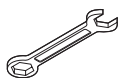

Llave o llave ajustable



Navaja



Pinzas de punta



Gafas de seguridad

Preparación antes de pintar o instalar

Pintura personalizada (opcional)

Primero, pruebe el ajuste de todas las extensiones para garantizar que tiene las que son correctas para su vehículo. No somos responsables por cualquier costo en el que pueda incurrir si no prueba las extensiones antes de pintarlas. Recomendamos que contrate a profesionales para el pintado personalizado de los productos. Lo ideal también es que se pinte antes de la instalación para eliminar cualquier problema de pulverización excesiva.

Limpieza del vehículo

Asegúrese de lavar su vehículo, especialmente el área donde se instalarán las extensiones del guardabarros, incluido el reborde interior, después de retirar la extensión original y el montaje de protección contra salpicaduras. Cualquier suciedad o residuo que no se haya limpiado o retirado puede causar un ajuste indebido de la extensión del guardabarros. Si está cubriendo óxido, recomendamos lijar el óxido y aplicar imprimación para prevenir un mayor deterioro del metal en el guardabarros. Asegúrese de secar el vehículo antes de la instalación. Las extensiones del guardabarros vienen listas para instalar; sin embargo, si necesita limpiarlas, utilice un detergente suave para lavarlas y luego séquelas completamente.

Instalación profesional (opcional)

Si bien se ha hecho el esfuerzo para que esta instalación sea tan simple como sea posible, la instalación profesional puede ser recomendable en algunos casos.

Pasos de instalación

NOTA: La aplicación real tal vez no sea igual a las ilustraciones.

Extensiones delanteras

Desengrane el montaje de la bombilla de posición lateral del alojamiento del faro de posición lateral. Retire la tuerca de montaje y retire el alojamiento del faro de posición lateral de la extensión del guardabarros de fábrica. Retenga la tuerca de montaje.

1

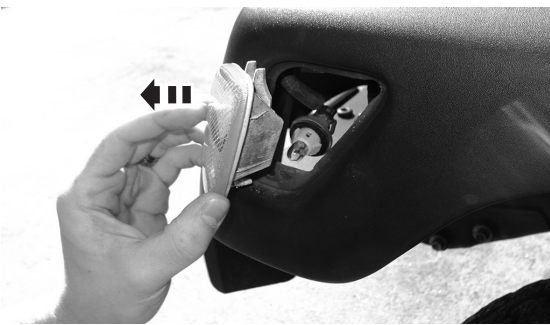

Retire las (8) tuercas de montaje de la extensión del guardabarros de fábrica.

2



Retire la extensión del guardabarros delantero y limpie el área de montaje.

3

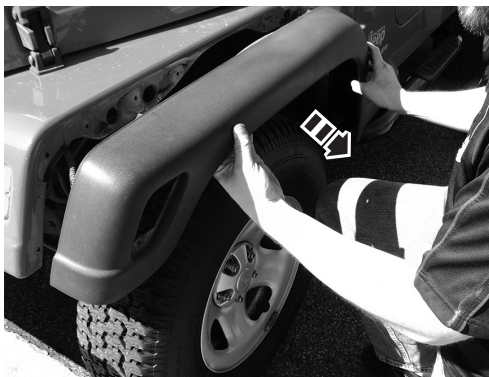

Afloje los (3) tornillos del escalón lateral instalado en fábrica y retírelos. Retire los tornillos restantes del guardabarros y límpielo.

4



Utilice una navaja para cortar e instalar el sello de caucho en el nuevo borde de la extensión del guardabarros, el cual se montará contra este.



Coloque un perno a través del orificio de la nueva extensión del guardabarros y coloque un separador negro en el perno del lado opuesto de esta para retenerla en su lugar. Repita el procedimiento con los orificios restantes.

5



Perno a través de este lado

6

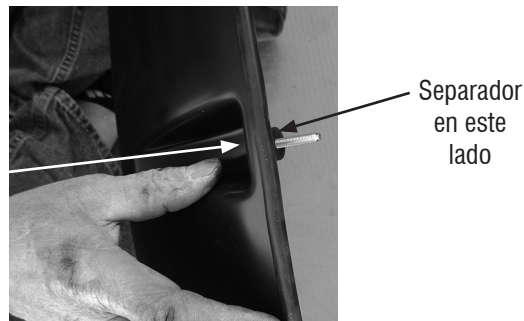

Alinee la nueva extensión del guardabarros en los orificios ubicados en el guardabarros. **NOTA:** La nueva extensión del guardabarros utiliza solamente (6) orificios.

7



Extienda la mano detrás de la extensión y coloque una arandela y una tuerca en cada perno para asegurar la extensión al guardabarros. **NO AJUSTE COMPLETAMENTE EN ESTE MOMENTO.**

8



Pasos de instalación

NOTA: La aplicación real tal vez no sea igual a las ilustraciones.

Con la extensión del guardabarros en posición final, ajuste todos los tornillos y tuercas usando solamente las herramientas de mano.
NO AJUSTE DEMASIADO.

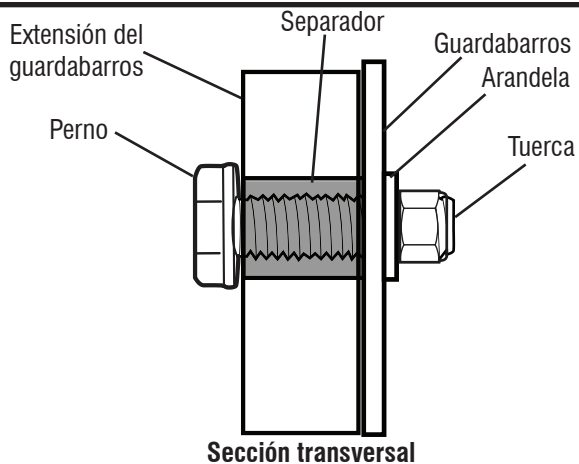

Sección transversal

9

Vuelva a instalar el montaje de la bombilla y el faro de posición lateral.



10



Deslice los (3) pernos a través del nuevo escalón lateral y ajústelos en los orificios de montaje del guardabarros.



11

Con el escalón lateral en posición final, ajuste los (3) tornillos usando solamente las herramientas de mano.
NO AJUSTE DEMASIADO.



12

Extensiones traseras

Retire las (8) tuercas de montaje de la extensión del guardabarros trasero de fábrica.

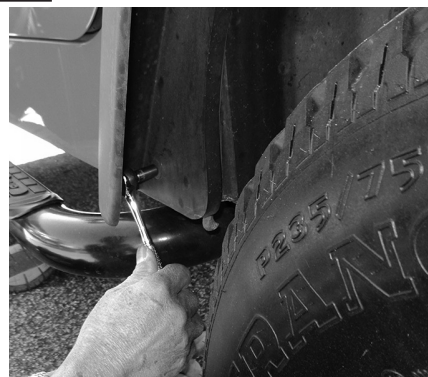

13

Retire la extensión del guardabarros trasero y limpie el área de montaje.



14

Desengrane los (2) pasadores de montaje de goma de la protección contra salpicaduras trasera a fin de obtener acceso detrás del guardabarros.



15

Pasos de instalación

NOTA: La aplicación real tal vez no sea igual a las ilustraciones.



Utilice una navaja para cortar e instalar el reborde de caucho en el nuevo borde de la extensión del guardabarros, el cual se montará contra este.



16



Coloque un perno a través del orificio de la nueva extensión del guardabarros y coloque un separador negro en el perno del lado opuesto de esta para retenerla en su lugar. Repita el procedimiento con los orificios restantes.



Perno a través de este lado

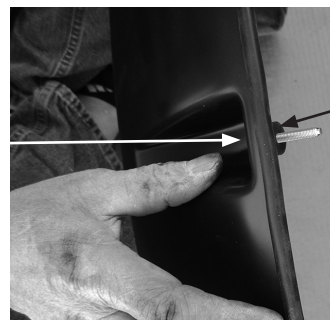

Separador en este lado

17

Alinee la nueva extensión del guardabarros en los orificios ubicados en el guardabarros.



18



Extienda la mano detrás de la extensión y coloque una arandela y una tuerca en cada perno para asegurar la extensión al guardabarros. **NO AJUSTE COMPLETAMENTE EN ESTE MOMENTO.**



19

Con la extensión del guardabarros en posición final, ajuste todos los tornillos y tuercas usando solamente las herramientas de mano. Vuelva a acoplar la protección contra salpicaduras que fue aflojada en el **Paso 15**. **NO AJUSTE DEMASIADO.**



20

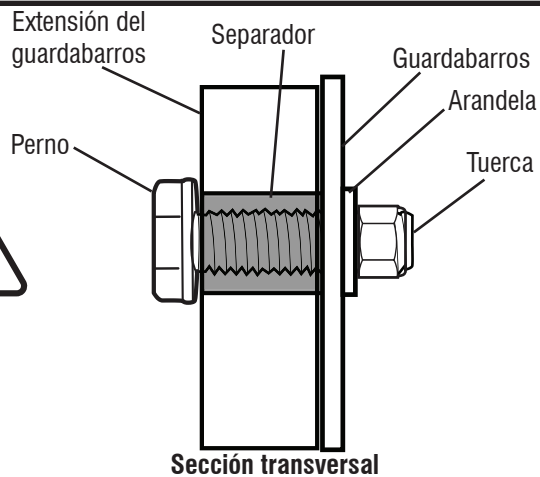

Repita desde el **Paso 1** hasta el **20** para el lado opuesto.

Cuidado y limpieza

- Las extensiones de guardabarros Lund se fabrican para ser duraderas; cualquier detergente que use para lavar su vehículo es suficiente para limpiar las extensiones. No utilice ningún detergente abrasivo fuerte.

¡Felicitaciones!

Usted ha adquirido uno de los tantos productos de marca de calidad Lund[®] que ofrece Lund International, Inc. Nos enorgullecen mucho nuestros productos y deseamos que disfrute años de satisfacción por su inversión. Nos hemos esforzado mucho para asegurarnos de que su producto sea de gran calidad en cuanto a ajuste, durabilidad, acabado y facilidad de instalación.

LUND[®]

Lund International

800-241-7219 • Visítenos en lundinternational.com

© 2014 Lund International, Inc. Todos los derechos reservados.

Lund[®] y el logo de Lund[®] son marcas registradas de Lund International, Inc.

