



INSTALLATION INSTRUCTIONS FOR MOUNTING

LUVERNE GRILL GUARDS WITH THE FOLLOWING MODEL NOS.:
330716/330718 AND 340716/340718 ON:

2007 AND NEWER 1500 CHEVROLET SILVERADO
2007 AND NEWER 1500 GMC SIERRA

1. READ THE INSTRUCTIONS COMPLETELY AND CHECK TO MAKE SURE THAT ALL OF THE REQUIRED PARTS ARE ON HAND BEFORE STARTING THE INSTALLATION. THE CARTON SHOULD CONTAIN:

- (1) OUTER RING PACKAGE
 - (1) OUTER RING ASSEMBLY
- (1) UPRIGHT/BRACKET PACKAGE:
 - (1) ASSEMBLED UPRIGHT, RH
 - (1) ASSEMBLED UPRIGHT, LH
 - (1) MOUNTING BRACKET, RH
 - (1) MOUNTING BRACKET, LH
 - (1) FASTENER PACKAGE
 - (1) CUSTOMER SERVICE PACKAGE

REFER TO FIGS. 1 & 2 FOR GUARD ASSEMBLY INSTRUCTIONS 2-11

2. LOOSEN AND REMOVE THE TWO BOLTS AND NUT THAT HOLD THE TOW HOOKS TO THE END OF THE FRAME. REMOVE THE TOW HOOKS.
3. INSTALL THE RIGHT HAND MOUNTING BRACKET (ITEM #4) INTO THE END OF THE FRAME. **(NOTE: WHEN INSTALLING THE BRACKET, BEND THE PLASTIC TAB IN THE AIR DAM TO THE OUTSIDE WHILE INSERTING THE BRACKET OR TRIM OFF THE TOP AND BOTTOM TABS EVEN WITH THE OUTSIDE HOLES, WITH A UTILITY KNIFE.)** FASTEN WITH THE 1/2"-13 X 1-1/2" BOLT (ITEM #10), 1/2"-13 X 4-1/2" HEX BOLT (ITEM #9), 1/2" LOCK WASHER (ITEM #16) AND THE 1/2"-13 SERRATED FLANGE NUT (ITEM #13). LEAVE LOOSE AT THIS TIME.
4. REPEAT STEP #3 ON THE LEFT SIDE.
5. INSTALL THE RIGHT HAND UPRIGHT (ITEM #2) **(NOTE: THE CHANNELS SHOULD BREAK TO THE OUTSIDE.)** ON THE RIGHT HAND MOUNTING BRACKET (ITEM #4) **(NOTE: USE THE BOTTOM HOLES IN THE MOUNTING BRACKETS FOR CHEVROLET SILVERADO AND THE TOP HOLES FOR THE GMC SIERRA.)** AND FASTEN WITH THE 1/2"-13 X 3" CARRIAGE BOLTS (ITEM #8), 1/2" SAE FLAT WASHERS (ITEM #18), AND THE 1/2"-13 CAP NUTS (ITEM #14). INSTALL ONLY THE LOWER BOLT AND ALLOW THE UPRIGHT TO TILT OUT. LEAVE LOOSE AT THIS TIME. YOU WILL NEED THE CLEARANCE TO GET THE RING INSTALLED.
6. REPEAT STEP #5 ON THE LEFT SIDE.
7. LOWER THE CENTER RING ASSEMBLY (ITEM #1) DOWN BEHIND THE UPRIGHTS AND INSTALL IN THE SLOTS OF THE UPRIGHTS AS SHOWN IN FIG. 1 & 2. IT WILL BE NECESSARY TO START TILTING THE UPRIGHTS TOWARD THE VEHICLE IN ORDER TO GET THE BOLTS INTO THE NUTS IN THE UPRIGHTS. MAKING SURE THE UPRIGHTS ARE CENTERED AND PARALLEL WITH THE BARS IN THE RING, FASTEN WITH 7/16"-14 X 1-1/4" HEX BOLTS (ITEM #11) AND 7/16" FLAT WASHERS (ITEM #18) INTO THE 7/16-14 CAPTIVE NUTS (ITEM #15) IN THE UPRIGHT MOUNTING PLATES. TIGHTEN TO 54 FOOT-POUNDS OF TORQUE.



(A LUVERNE Company)

1200 E. Birch St.

Brandon, SD 57005

REVISED 31MAR11 LVL B
REVISED 17SEP07 LVL A
202336 SHEET 1 OF 4 11DEC06

8. CHECK THAT THE GRILL GUARD IS CENTERED ON THE GRILLE AND THE REAR OF THE UPRIGHT CUTOUT IS APPROXIMATELY 1/2"-3/4" AWAY FROM THE FACE OF THE BUMPER.
9. TIGHTEN THE 1/2" NUTS ON THE CARRIAGE BOLTS FASTENING THE MOUNTING BRACKETS TO UPRIGHTS TO 75 FOOT-POUNDS OF TORQUE.
10. TIGHTEN THE 1/2" BOLTS THAT FASTEN THE BOTTOM MOUNTING BRACKETS TO THE FRAME TO 75 FOOT-POUNDS OF TORQUE. (NOTE: APPLY PRESSURE ON THE TOP OF THE GUARD TOWARD THE VEHICLE WHEN TIGHTENING THE FRAME BOLTS.)
11. INSTALL THE RIGHT AND LEFT UPRIGHT END CAPS (ITEMS #20 & #21) WITH THE 1/4"-20 X 3/8" BUTTON HEAD SCREWS (ITEM #19).

SERVICE PARTS LIST

ITEM	PART NO.	QTY	DESCRIPTION
1	202339	1	RING WELDMENT – CHROME
1	202344	1	RING WELDMENT – BLACK
2	202329	1	UPRIGHT WELDMENT – CHROME, RH
2	202337	1	UPRIGHT WELDMENT – BLACK, RH
3	202330	1	UPRIGHT WELDMENT – CHROME, LH
3	202338	1	UPRIGHT WELDMENT – BLACK, LH
4	202321	1	MOUNTING BRACKET – RH
5	202322	1	MOUNTING BRACKET – LH
6	201122	4	TAPPING BAR – 13.000"
7	107226	2	RUBBER EXTRUSION – 29.250
8	107231	4	ROUND HEAD BOLT – 1/2"-13 X 3", SST
9	100107	2	HEX HEAD SCREW – 1/2"-13 X 4-1/2", ZP
10	100088	2	HEX HEAD SCREW-1/2"-13 x 1-1/2", ZP
11	105939	4	HEX HEAD SCREW-7/16"-14 x 1-1/4", SST
12	103715	12	SELF TAPPING SCREW – 1/4"-20 X 5/8"
13	100123	2	SERRATED FLANGE NUT – 1/2"-13
14	104994	4	HEX CAP NUT – 1/2"-13, SST
15	100083	4	NUT CAPTIVE – 7/16", BLK
16	100121	2	LOCK WASHER – 1/2", ZP
17	104995	4	FLAT WASHER – SAE, 1/2", SST
18	103286	4	FLAT WASHER – 7/16", SST
19	105286	2	BUTTON HEAD SCREW – 1/4"-12 X 3/8", BLACK
20	201818	1	UPRIGHT END CAP – RH
21	201819	1	UPRIGHT END CAP – LH
22	105303	2	DECAL – MATTE BLACK, 1" X 10"
23	100252	1	DECAL – LOGO, 1 X 3



(A LIVERNE Company)

1200 E. Birch St.

Brandon, SD 57005

REVISED 31MAR11 LVL B
REVISED 17SEP07 LVL A
202336 SHEET 2 OF 4 11DEC06

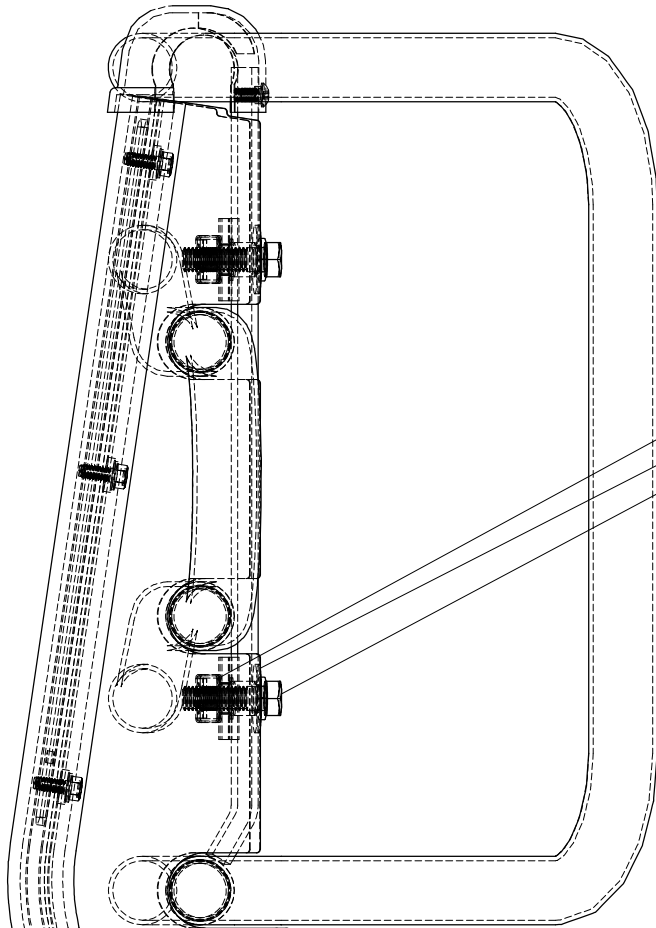

- 7/16" CAPTIVE NUT
- 7/16" FLAT WASHER, SST
- 7/16-14 X 1-1/4" HEX BOLT, SST

fig. 1

- 1/2"-13 X 3" CARR BOLT, SST
- 1/2" SAE FLAT WASHER, SST
- 1/2"-13 CAP NUT, SST

- 1/2"-13 SERRATED FLANGE NUT
- 1/2"-13 X 4-1/2" HEX BOLT

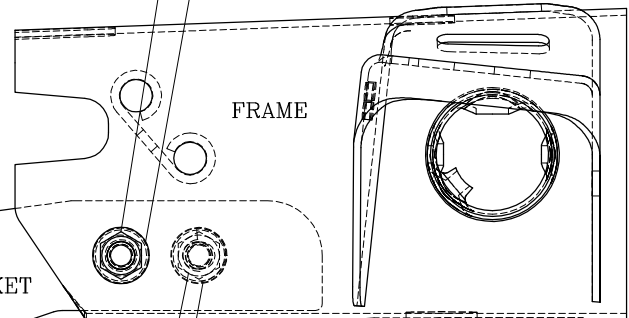

MOUNTING BRACKET

FRAME

THESE HOLES
FOR GMC

THESE HOLES
FOR CHEVROLET

- 1/2" LOCK WASHER
- 1/2"-13 X 1-1/2" HEX BOLT

- 1/2"-13 X 3" CARR BOLT, SST
- 1/2" SAE FLAT WASHER, SST
- 1/2"-13 CAP NUT, SST

REVISED 31MAR11 LVL B
REVISED 17SEP07 LVL A
202336 SHEET 3 OF 4 11DEC06



(A LIVERNE Company)

1200 E. Birch St.

Brandon, SD 57005

SERVICE PARTS LIST

MODEL NO. - 330716/330718
 MODEL NO. - 340710/340718

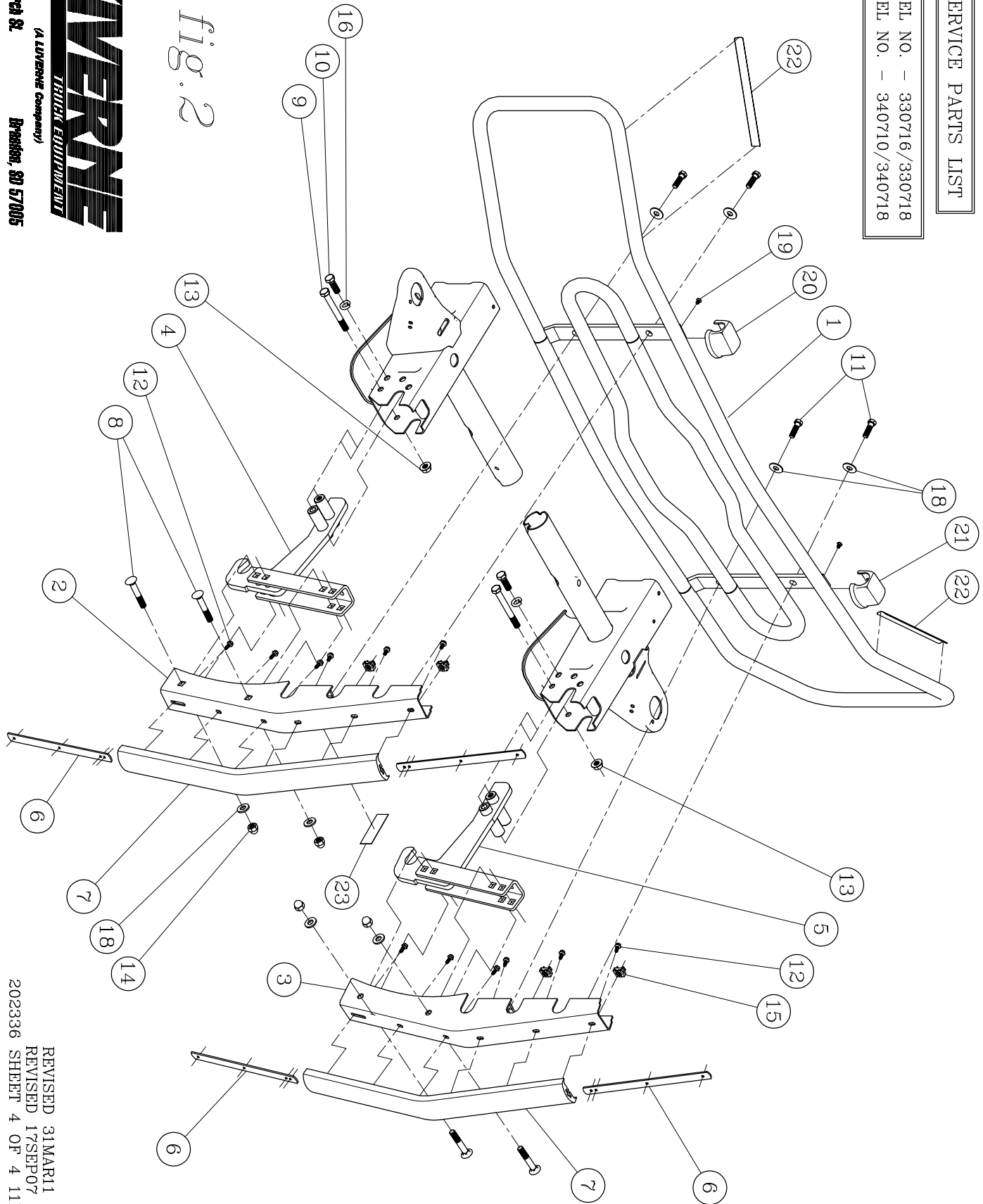

fig. 2



1200 E. Birch St. Denver, CO 80202

REVISED 31MAR11 LVL B
 REVISED 17SEP07 LVL A
 202336 SHEET 4 OF 4 11DEC06