

INSTALLATION INSTRUCTIONS AND PARTS LIST

MODEL 415078, 415088, GRIP STEPS (BOARDS ONLY)

UNIVERSAL APPLICATIONS

1. Read instructions completely and check to make sure that all required parts (listed on the service parts list) are on hand before starting the installation.
2. Follow the instructions included with the specific bracket package that you are using to mount the brackets to your vehicle.
3. Step assembly:
 - 3.1 Before attaching the grip steps to the brackets, slide the appropriate number of support braces (item #2) into the channel of the step (item #1).
 - 3.2 Slide the end cap (item #3) over the front and rear of each step. Using the supplied #8 x 1/2" self drilling tek screw (item #8), screw the end cap to the bottom of the step.
4. Attaching the step to the mounting bracket:
 - 4.1 Set the step on the mounting brackets, and slide each support brace over the top of each mounting bracket. Attach the flat spacer plate (item #4) to the bottom of the step, between the support brace, and the top of the mounting bracket.
 - 4.2 Using the supplied 5/16-18 x 1" carriage bolt, washer, and flange nuts, (item #5, 6, 7), attach the step assembly, flat spacer plate and mounting bracket. **(NOTE: Some of the flange nuts are supplied in the specific bracket package, not the step package.)**
 - 4.3 Set the step plate in the correct position and tighten all fasteners.
Torque all 5/16" fasteners to 19 LB FT.

SERVICE PARTS LIST

ITEM	PART NO.	QTY	DESCRIPTION
1	551384	2	EXTRUSION-AL,77.62, GRIP STEP,BLK,415078
1	551385	2	EXTRUSION-AL,87.75,GRIP STEP,BLK,415088
2	551296	8	SUPPORT BRACE, UPPER, GALV
3	551394	4	CAP-END,GRIP STEP, BLACK, PLASTIC
4	551298	8	SPACER PLATE, LOWER, BLACK
5	108683	16	BOLT-CRG,5/16-18 X 1.0", SST
6	101369	16	WASHER-FLAT,5/16,SST
7	102680	16	NUT-SERR FLG,HX,SST,WX,5/16-18
8	107958	8	SCR-TEK #8-18 X 1/2",SST,BLK

LIVERNE
TRUCK EQUIPMENT

(A LIVERNE Company)

1200 E. Birch St.

Brandon, SD 57005

REV B 03DEC10

REV A 10JUL09

551267 SHEET 1 OF 2 20AUG08

SERVICE PARTS LIST

MODEL NO. - 415078
- 415088

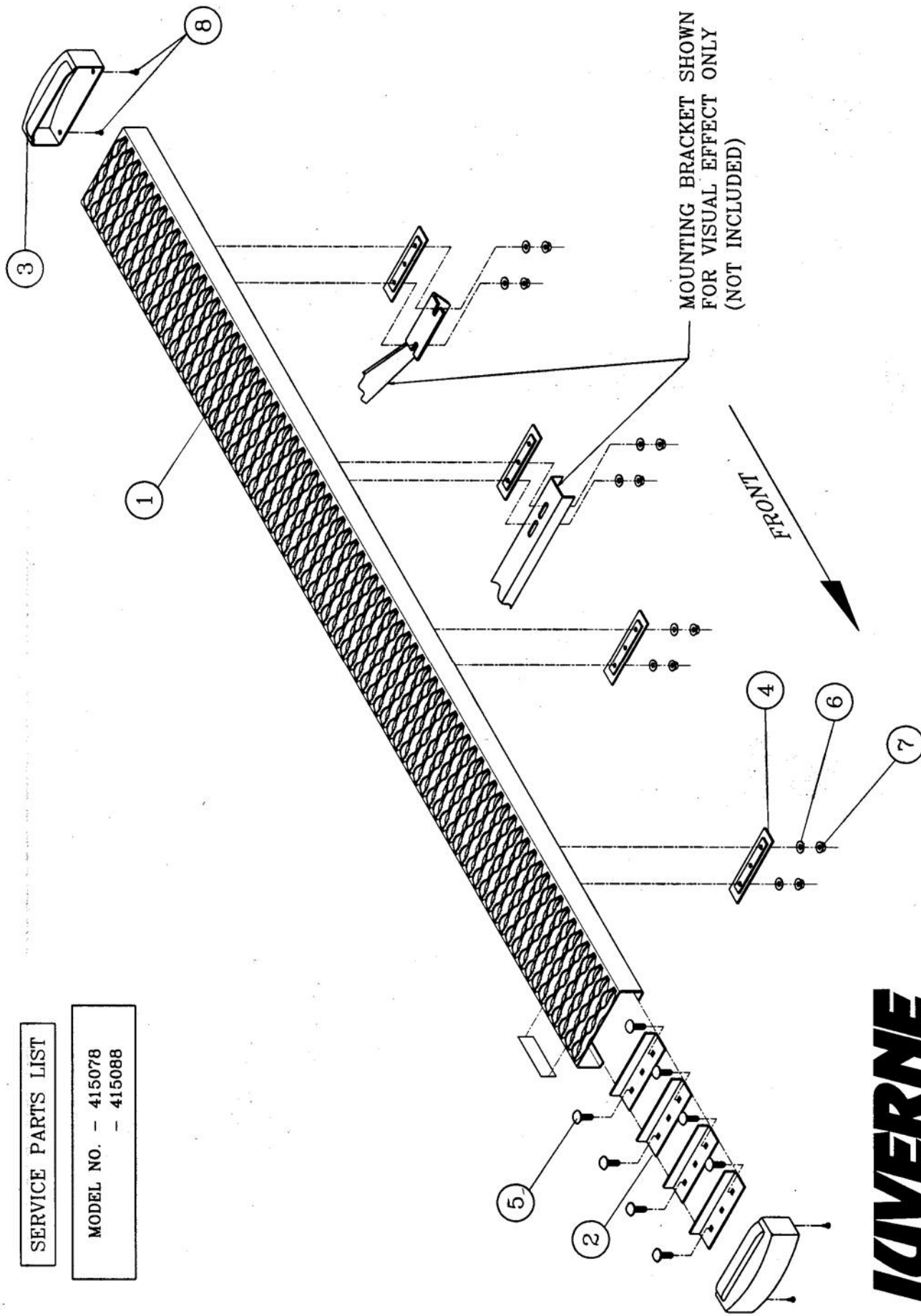

LAVERNE
TRUCK EQUIPMENT
(A LAVERNE Company)

1200 E. Birch St.
Brandon, SD 57005

REV B 03DEC10
REV A 10JUL09
551267 SHEET 3 20AUG08

INSTALLATION INSTRUCTIONS AND PARTS LIST

APPLICATION: MODEL **401663** GRIP STEP BRACKETS ON:
2016+ NISSAN TITAN CREW CAB PICKUPS
ROCKER PANEL MOUNT APPLICATION



NO DRILL APPLICATION

1. READ INSTRUCTIONS COMPLETELY AND CHECK TO MAKE SURE THAT ALL REQUIRED PARTS (LISTED ON SERVICE PARTS LIST) ARE ON HAND BEFORE STARTING THE INSTALLATION.
2. INSTALL BRACKETS (ITEM #1), USING THE SUPPLIED FASTENERS (ITEM #2) M8 X 1.25, X 30mm SCREW, (ITEM #3) 5/16 LOCK WASHER, & (ITEM #4) 5/16 FLAT WASHER, IN THE THREADED HOLES OF THE ROCKER PANEL. AS SHOWN IN FIG 1.
3. **NOTE: REMOVE ANY FACTORY PLUGS FROM THREADED MOUNTING HOLES IF EQUIPPED.**
4. TIGHTEN ALL M8 FASTENERS TO 19 LB/FT.
5. INSTALL BOARD PER SUPPLIED INSTRUCTIONS.

SERVICE PARTS LIST

ITEM	PART NO.	QTY	DESCRIPTION
1	552967	8	BRKT-MTG, GRIP STEP, 401663
2	102549	16	M8-1.25 X 30MM SCREW, ZP
3	100030	16	5/16 LOCK WASHER, ZP
4	100034	16	5/16 FLAT WASHER, ZP

SERVICE PARTS LIST

MODEL NO. - 401663

USE THESE 2 HOLES
FOR DRIVERS SIDE (LEFT),
FOR THE PASSENGER
SIDE (RIGHT) USE
THE OPPOSITE 2 HOLES

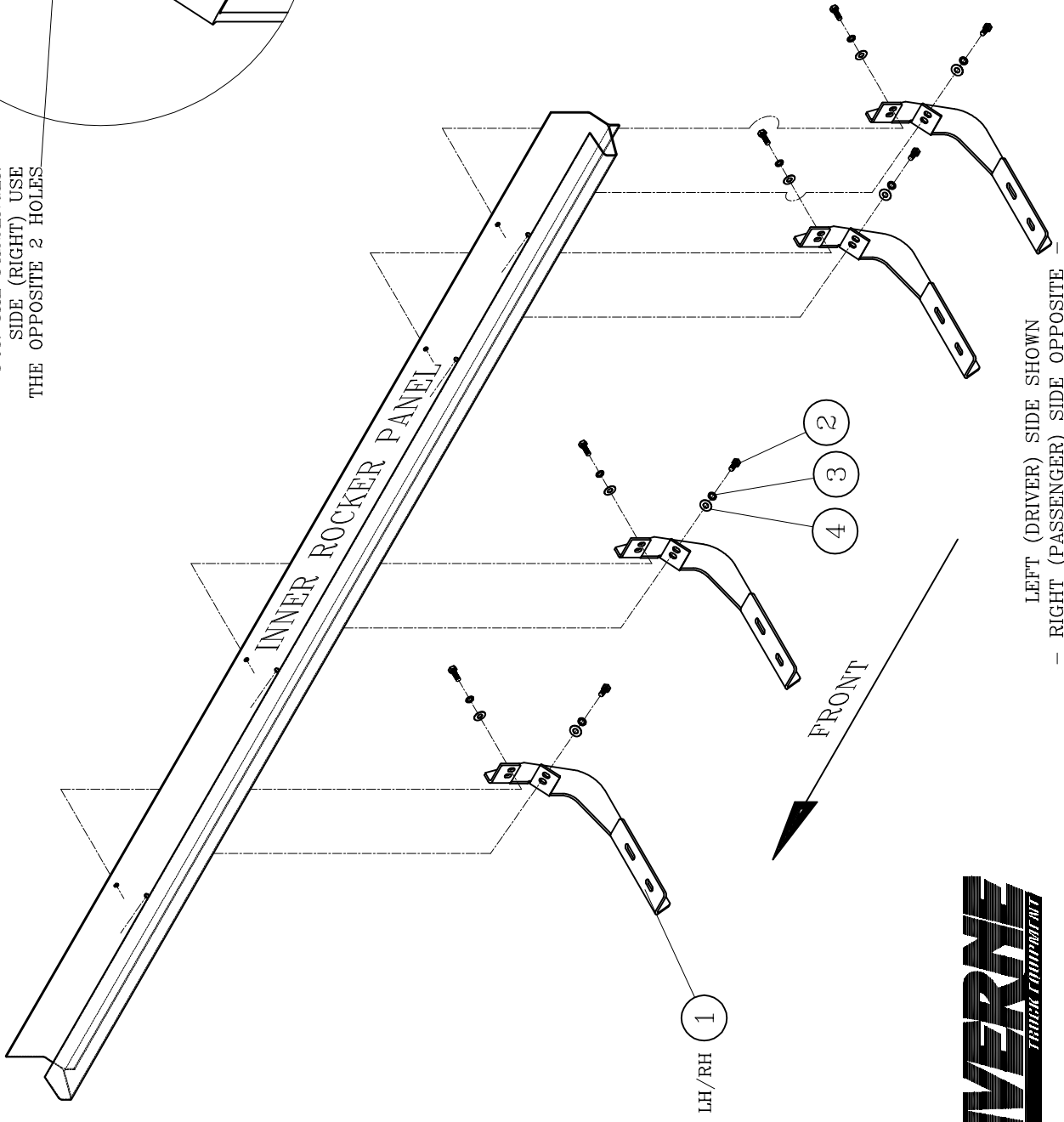
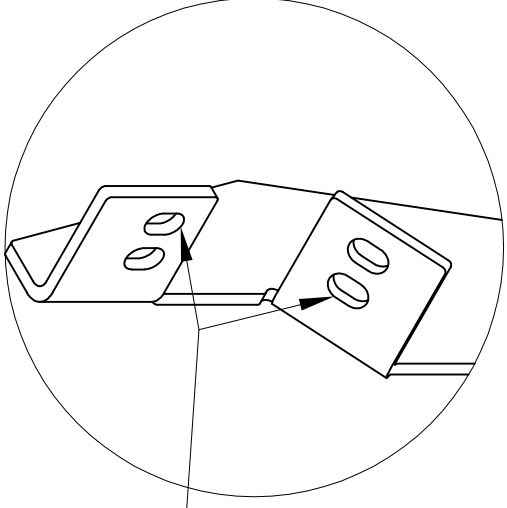

LEFT (DRIVER) SIDE SHOWN

- RIGHT (PASSENGER) SIDE OPPOSITE