

# AC-9219-02

## 2024-UP CAN AM MAVERICK R, FRONT RACE BUMPER, BUILDER KIT

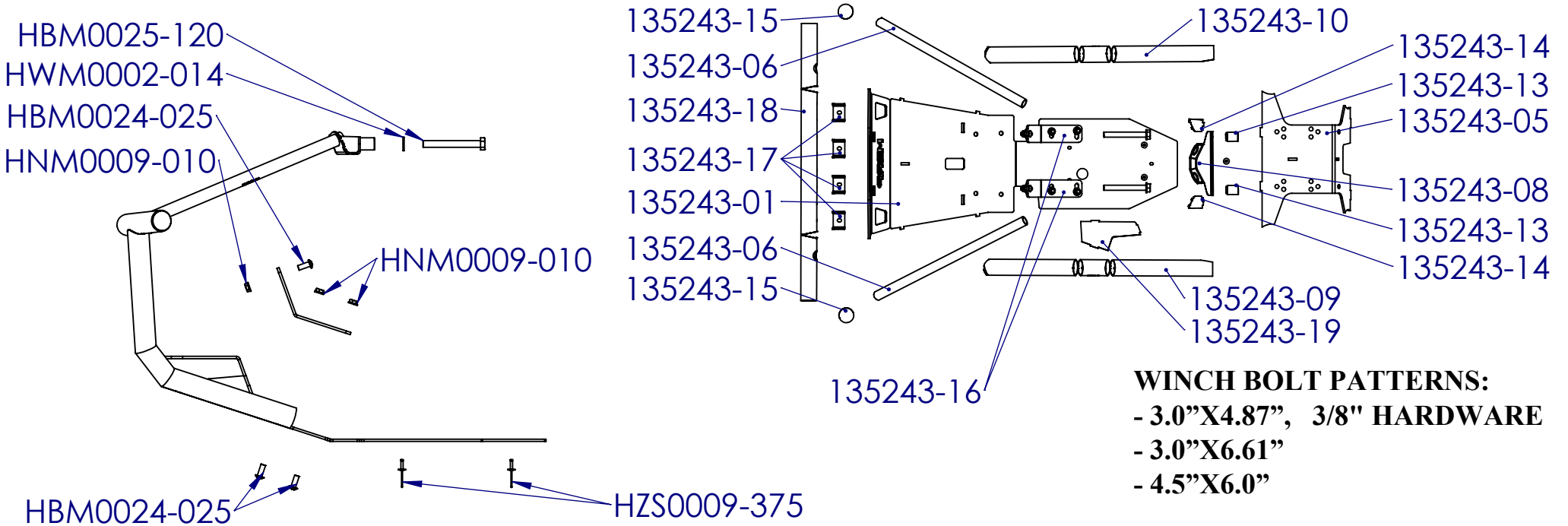

**WINCH BOLT PATTERNS:**  
 - 3.0"X4.87", 3/8" HARDWARE  
 - 3.0"X6.61"  
 - 4.5"X6.0"

**FAIRLEAD BOLT PATTERN:**  
 - 10" CENTERS, 3/8" HARDWARE

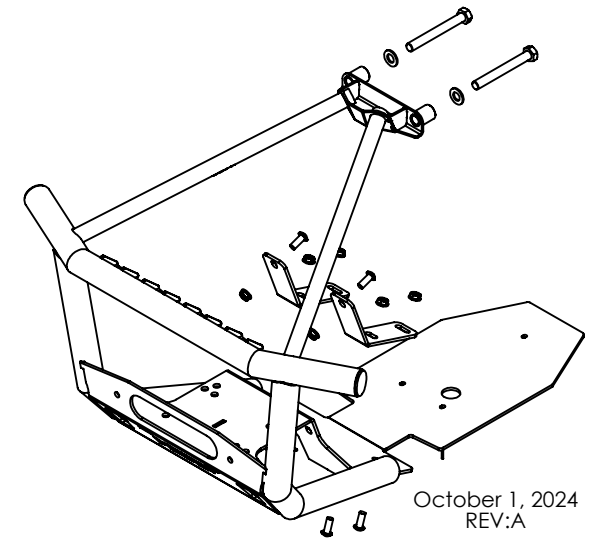

	PART NUMBER	DESCRIPTION	AC-9219-02
1	135243-01	SKID PLATE	1
2	135243-05	WINCH PLATE	1
3	135243-06	UPPER STRUT	2
4	135243-08	UPPER TUBE MOUNT	1
5	135243-09	1X5243-03 RAW CUT	1
6	135243-10	1X5243-04 RAW CUT	1
7	135243-13	SPACER	2
8	135243-14	TUBE MOUNT GUSSET	2
9	135243-15	END CAP	2
10	135243-16	BACKING PLATE	2
11	135243-17	LIGHT TAB	4
12	135243-18	135243-02 RAW CUT	1
13	135243-19	WINCH GUSSET	1
14	HBM0024-025	SCREW, BUTTON HEAD, M10-1.5X25MM, GRADE 10.9, BLACK OXIDE	6
15	HNM0009-010	FLANGE NUT, LOCKING, M10, ZINC PLATED	6
16	HBM0025-120	BOLT, HEX, M14-2.0X120MM - GRADE 10.9, ZINC COATED	2
17	HWM0002-014	WASHER, FLAT, M14, ZINC COATED	2
18	HZS0009-375	RIVET, 3/16" X 0.700" LONG	3