

AT-9300PT

Single, Slip-On Exhaust,
2014-UP Kawasaki Teryx
750/800, 2012- UP Teryx 4,
750/800

MBRP
POWERSPORTS

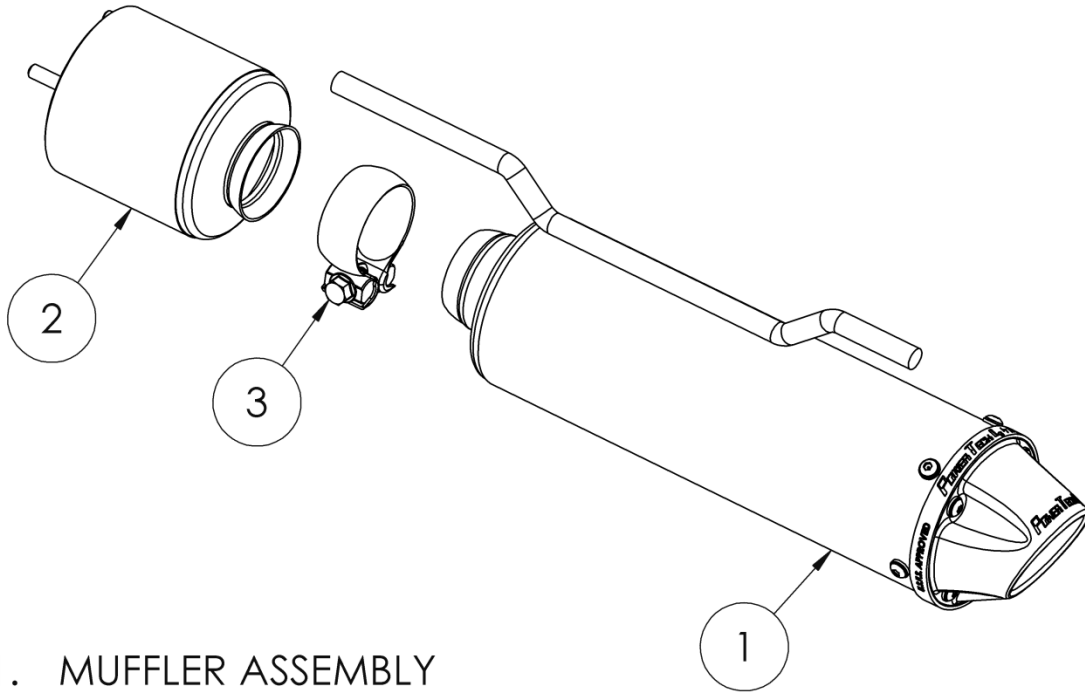

1. MUFFLER ASSEMBLY
2. EXPANSION CHAMBER
3. SWIVEL CLAMP

PLEASE READ BEFORE STARTING INSTALLATION

While MBRP Inc. has made every effort to ensure that all components of this system are of superior quality and properly packaged, it is the installer's responsibility to ensure the following before removal of the factory exhaust:

- that ALL components shown above are present.
- that ALL mating components fit together.
- that there are no damaged components.
- that the system you have purchased is appropriate for your vehicle year, model and configuration.
- that the system will not interfere with any modifications previously installed or planned.
- that you have read and understand these instructions.

If you have any questions or are uncertain about any aspect of the installation of this system to your vehicle please contact your dealer before commencing installation.

Removal of Stock Exhaust:

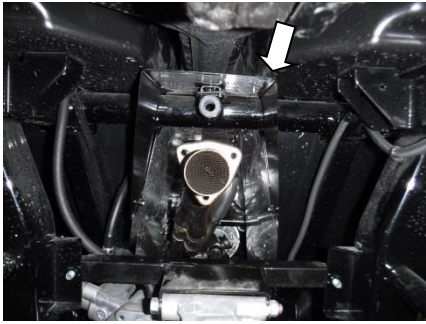

Figure 1

1. Remove the 3 nuts and spacers securing the muffler inlet to the exhaust pipe. Take care not to drop the spacers. Retain the nuts and spacers for the installation. Leave the gasket on the vehicle exhaust pipe.

Refer to Figure 1.

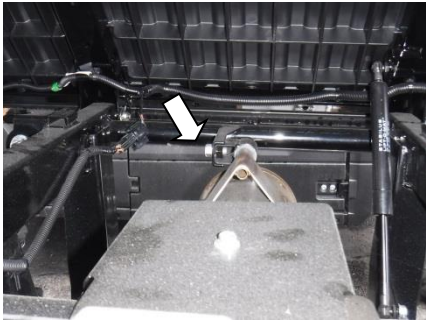

Figure 2

2. Remove the rear hanger bolt and hanger.

Refer to Figure 2.

3. Remove the muffler by sliding the hanger out of the front rubber isolator.

Installation of MBRP Powersports Exhaust:



Figure 3

1. Using the factory nuts and spacers, install the **Expansion Chamber** onto the engine pipe. Tighten slowly and evenly.

Refer to Figure 3.

2. Place the **Swivel Clamp** over the **Expansion Chamber** outlet.

3. Install the **Muffler Assembly** into the **Expansion Chamber** and factory front rubber isolator.

Refer to Figure 4.

4. Install the factory rear hanger and bolt. Notice the "UPPER" marking on the factory hanger

Refer to Figure 5.

5. Center and tighten the **Swivel Clamp**.

Refer to Figure 4.

6. Ensure there is adequate clearance between the exhaust system and other parts of the vehicle or accessories.



Figure 4

Note: It is recommended that the muffler screws be retightened after the first ride and checked periodically thereafter, tightening if necessary.



Figure 5



Congratulations! You are ready to begin experiencing the improved performance and driving excitement of your MBRP Powersports ATV Exhaust upgrade. We know you will enjoy your purchase.



Figure 1



Figure 2



Figure 3



Figure 4

Spark Arrestor Maintenance

In order to maintain optimal performance, the spark arrestor screen should be cleaned after every 30-35 hours of use.

Clean-out Instructions:

Make sure the vehicle is cool before completing the clean-out procedure.

1. Using a 4mm hex key, remove the 4 screws securing the outlet cap or tip. **(Figure 1)**
2. Remove the outlet cap to expose the spark arrestor screen insert. **(Figure 2)**
3. Remove the screen insert. **(Figure 3)**
4. Using a wire brush, thoroughly brush the screen to remove residue. **(Figure 4)**
5. Replace the screen and cap.
6. Tighten the screws to 60 in-lbs (6.8 Nm).