

S5320

2009-UP TOYOTA TUNDRA,
DOUBLE CAB STANDARD BED/ CREW MAX
SHORT BOX,
4.6L/5.7L V8 , CAT-BACK, 3.0" TURN DOWN

MBRP®

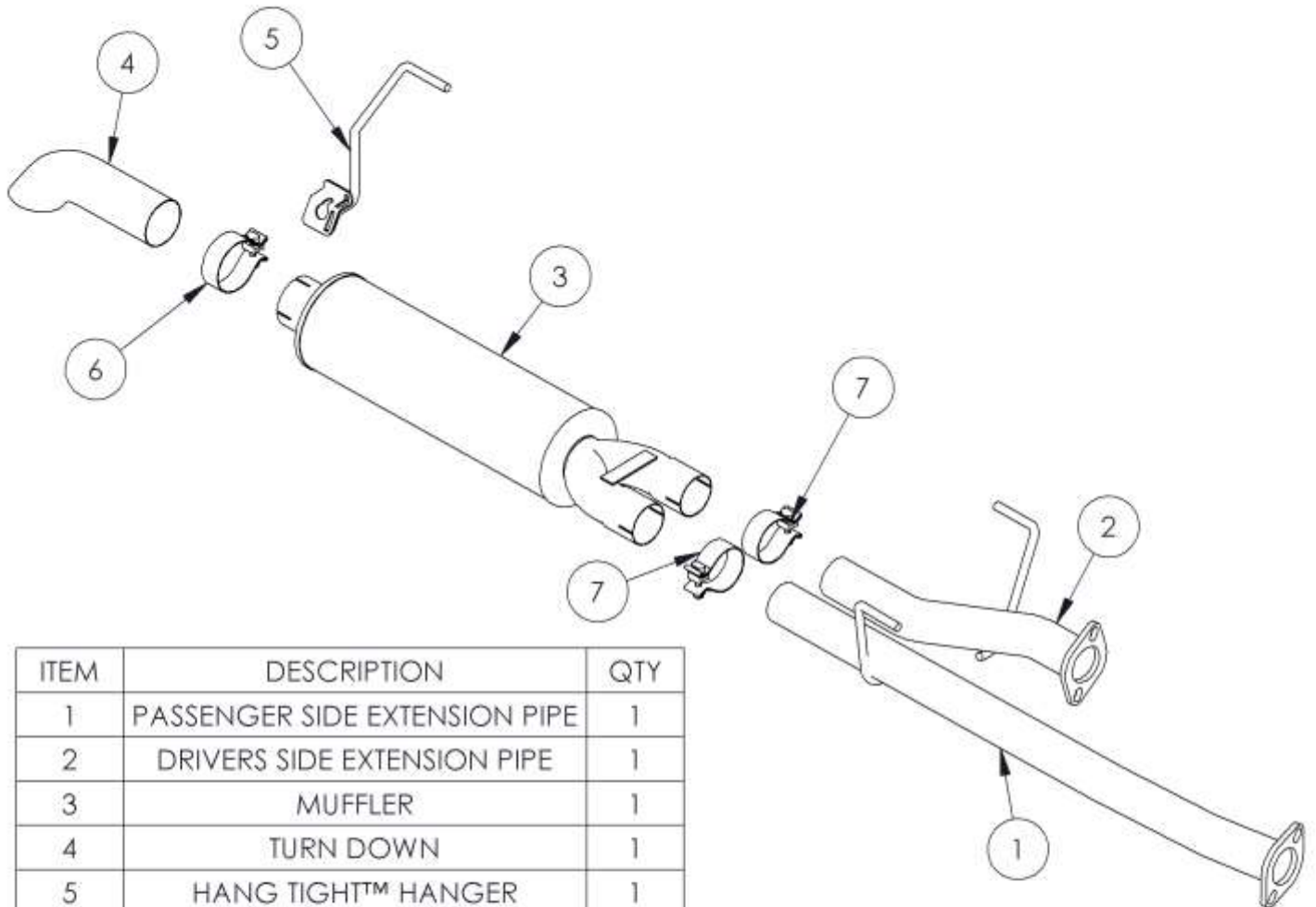

ITEM	DESCRIPTION	QTY
1	PASSENGER SIDE EXTENSION PIPE	1
2	DRIVERS SIDE EXTENSION PIPE	1
3	MUFFLER	1
4	TURN DOWN	1
5	HANG TIGHT™ HANGER	1
6	3.0" BAND CLAMP	1
7	2.5" BAND CLAMP	2

PLEASE READ BEFORE STARTING INSTALLATION

While MBRP has made every effort to ensure that all components of this system are of superior quality and properly packaged, it is the installer's responsibility to ensure the following before removal of the factory exhaust:

- that ALL components shown above are present.
- that ALL mating components fit together.
- that there are no damaged components.
- that the system you have purchased is appropriate for your vehicle year, model and configuration.
- that the system will not interfere with any modifications previously installed or planned.
- that you have read and understand these instructions.

If you have any questions or are uncertain about any aspect of the installation of this system to your vehicle please contact your dealer before commencing installation.

MBRP[®]

Removal of Stock System:



Figure 1



Figure 2



Figure 3



Figure 4



Figure 5

1. Apply a penetrating lubricant liberally to all exhaust fasteners, hangers and rubber insulators.

2. Remove hardware from stock extension pipes. Keep for reinstallation. **Refer to Figure 1.**

3. Remove exhaust from rubber insulators. **Refer to Figure 2.**

4. Remove the exhaust from the rearmost hanger. Leave the rubber insulators on the truck for installation. **Refer to Figure 3.**

Installation of MBRP Inc. Performance Exhaust:

1. Install the **Driver Side Extension Pipe** reusing the existing hardware and attaching the hanger to the existing rubber insulator. Tighten the hardware leaving it loose enough for some adjustment. **Refer to Figure 4.**

2. Install the **Passenger Side Extension Pipe** reusing the existing hardware. Tighten the hardware leaving it loose enough for some adjustment. **Refer to Figure 5.**

3. Slide the **2.5" Band Clamps** over the **Passenger Side Extension Pipe** and the **Driver Side Extension Pipe**. Install the **Muffler** onto the two extension pipes. **Refer to Figure 6.**



Figure 6

MBRP[®]

4. Install the **Hang Tight™ Hanger** onto **3.0" Band Clamp** using the procedure shown below. (Hang Tight™ Hanger not exactly as shown).

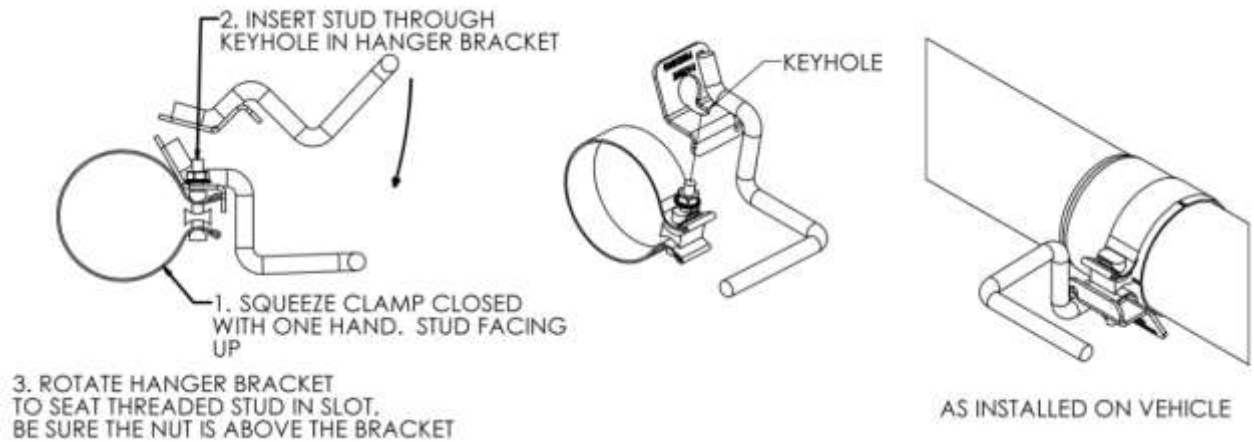

5. Slide the **3.0" Band Clamp Assembly** over the outlet side of the **Muffler**. Position the **Turn Down** and loosely attach it to the **Muffler**. Install the **3" Hanger Clamp** into the existing rubber insulator.

6. Align the exhaust as required. Starting at the front of the exhaust, tighten all clamps and connections.

7. Adjust Tail Pipe and Check along the whole length of the exhaust system all hardware and clamps, starting at the front and working rearward to secure the system. Check along the full length of the exhaust system to ensure there is adequate clearance for fuel lines, vent lines, brake lines, frame, bodywork, suspension, and any wiring, etc. If there is any interference detected, relocate, or adjust to provide adequate clearance.

8. Ensure all clamp connections are secure and components are unable to rotate or slide. Band clamps require approximately 45 lbft (60 Nm) of torque. Verify clearances, system security and band clamp torque after 30-60 miles (50-100 km) of driving.

Congratulations! You are ready to begin experiencing the improved power, sound and driving experience of your **MBRP** Inc. performance exhaust system. We are confident that you will enjoy your purchase.