

# S61120P

1998.5-2002 DODGE 2500/3500, 5.9L CUMMINS, TURBO-BACK, 5.0" SINGLE SIDE

# MBRP

26-Mar-21

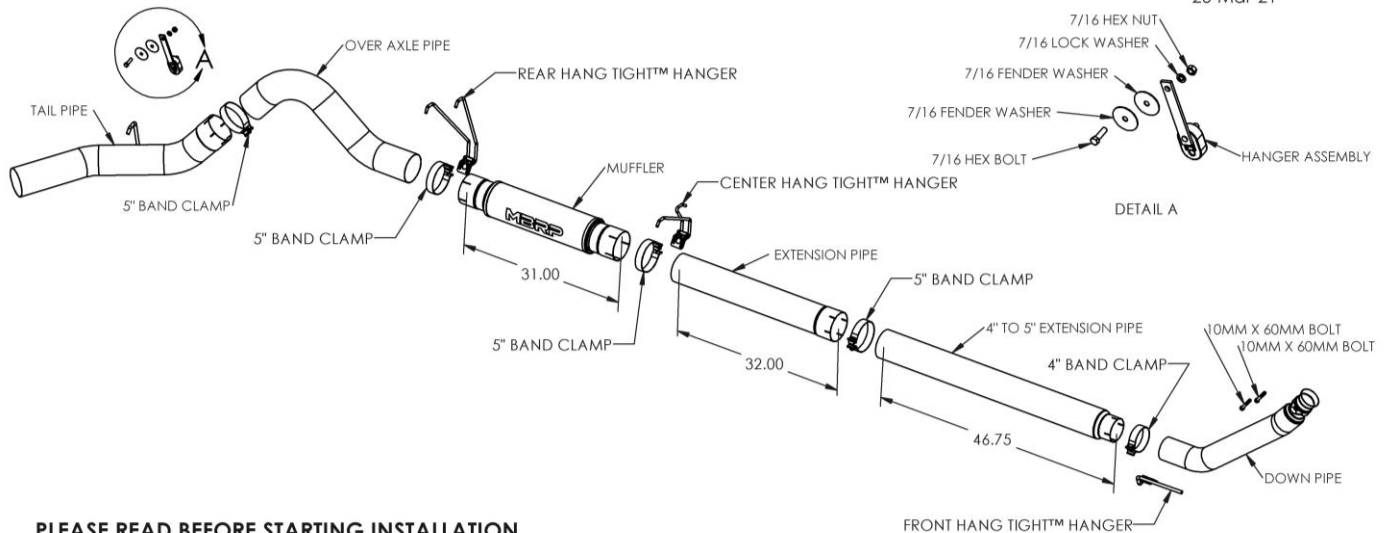

### PLEASE READ BEFORE STARTING INSTALLATION

MBRP Ltd. has made every effort to ensure that all components of this system are of superior quality and properly packaged. It is the installer's responsibility to ensure that all components are present and fit together as shown. Please also ensure that all components are undamaged before removal of the factory exhaust. Finally, check that this system properly matches the make and model of the vehicle and will not interfere with previous or planned modifications.

### Removal of Stock System:

1. Separate the stock exhaust system at the slip joint by the muffler. Remove the exhaust from rubber hangers and remove the system from under the truck.
2. Using a socket or wrench, remove the two bolts at the turbo flange and remove the stock down pipe.

### Installation of MBRP Performance Exhaust:

1. Install the **Down Pipe** in the same position as the stock down pipe placing the hanger into the OEM rubber insulator and attaching the flared end to the turbo using the supplied hardware. Do not fully tighten until all components are in place.
2. Install the **4" to 5" Extension Pipe (46.75")** over the **Down Pipe** securing it with the **4" Band Clamp** and **Front Hang Tight™ Hanger** (See figure 2 for Hang Tight™ instructions, Hang tight hanger not exactly as shown). Install the **32" Extension Pipe** onto the **4" to 5" Extension Pipe** securing it with a **5" Band Clamp**. The combination of these two **Extension Pipes** provides the required length to fit a Quad Cab Long Bed truck, for Quad Cab Short Bed cut the **32" Extension Pipe** to 16" and for Regular Cab models cut down to 12".
3. Install the **Muffler** over the required pipe securing it with the **Center Hang Tight™ Hanger** so that the exhaust will flow smoothly over the louvers. **Refer to Figure 1.**

# MBRP



Figure 1

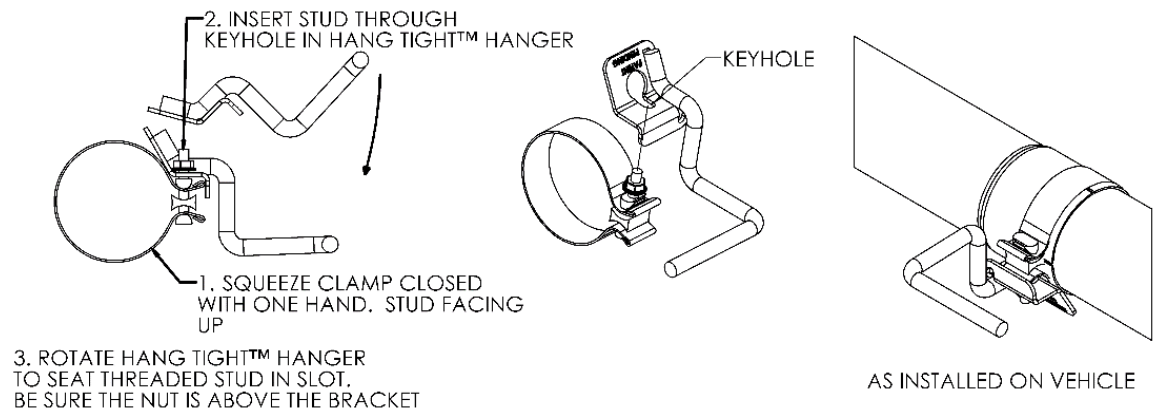

Figure 2

4. Install the **Rear Hang Tight™ Hanger** into the two OEM rubber hangers located above the outlet of the **Muffler**.
5. Remove the factory rubber insulator for the factory tail pipe. Install the **Over-Axle Pipe** and **5” Band Clamp** onto the **Tail Pipe**. From the rear of the truck, slide the assembly over the axle and attach to the outlet of the **Muffler**. Move the **Tail Pipe** into approximate position. Using the factory hole provided in the frame directly above the tail pipe hanger, attach the hanger provided (**HG002**) using the supplied hardware. Finish hanging the **Tail Pipe**.
6. Align the edge of band clamp with the edge of the joint it is connecting. Tighten all hardware and clamps, starting at the front and working rearward to secure the system. Check along the full length of the exhaust system to ensure there is adequate clearance for fuel lines, vent lines, brake lines, frame, bodywork, suspension, and any wiring, etc. If there is any interference detected, relocate, or adjust to provide adequate clearance. Ensure all clamp connections are secure and components are unable to rotate or slide. Band clamps require approximately 45 lb-ft (60 N-m) of torque. Verify clearances, system security and band clamp torque after 30-60 miles (50-100 km) of driving.

**Congratulations!** You are ready to begin experiencing the improved performance and driving pleasure of your **MBRP** performance exhaust system. We know you will enjoy your purchase.