



INSTALLATION INSTRUCTIONS



2021 FORD F-150 3.5L

PART NO. 19590

BILL OF MATERIALS:

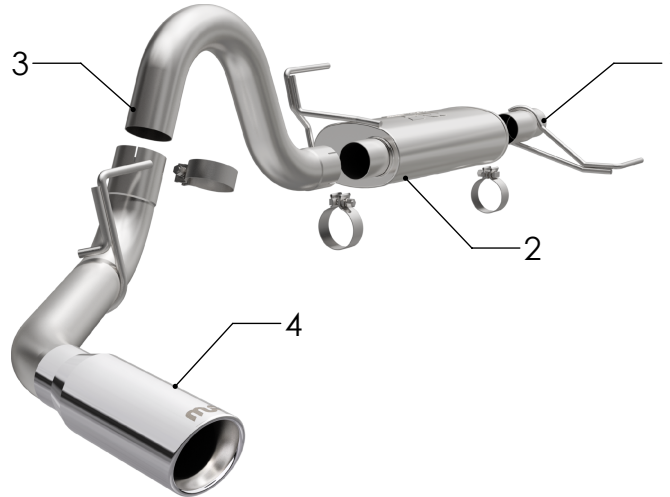

- 1. INLET PIPE ASSY
- 2. MUFFLER ASSY
- 3. OVER AXLE PIPE
- 4. P/S TAILPIPE ASSY



WEAR SAFETY GLASSES



READ INSTRUCTIONS THOROUGHLY BEFORE INSTALLING PRODUCT



SPRAY LUBRICANT

To ease removal of existing exhaust components (especially on older vehicles) spray penetrating lubricant on all fasteners and hangers/insulators that will be loosened or removed and let soak before disassembly.

HARDWARE KIT:

- 1. [3] 3.00" Clamp

SHOP SUPPLIES:

MINIMUM REQUIRED TOOLS:



15 mm



Hanger Tool (Or Pry Bar)

MAGNAFLOW RECOMMENDS PROFESSIONAL INSTALLATION ON ALL THEIR PRODUCTS



WARNING: When working on, under, or around any vehicle exercise caution. Please allow the vehicle's exhaust system to cool before removal, as exhaust system temperatures may cause severe burns. If working without a lift always consult vehicle manual for correct lifting specifications. Always wear safety glasses and ensure a safe work area. Serious injury or death could occur if safety measures are not followed.

ATTENTION: Always install any supplied band or U-bolt clamps to the proper torque specifications of 40-45 ft-lb for band clamps and 30-35 ft-lb for U-bolt clamps. Over tightening will result in the clamps breaking and will NOT be warranted by MagnaFlow.

MAGNAFLOW: 1901 Corporate Centre Dr - Oceanside, CA 92056 | 1(800)990-0905

Technical Support: 1(800) 959-9226 | Email: moreinfo@magnaflow.com

INSTALLATION INSTRUCTIONS

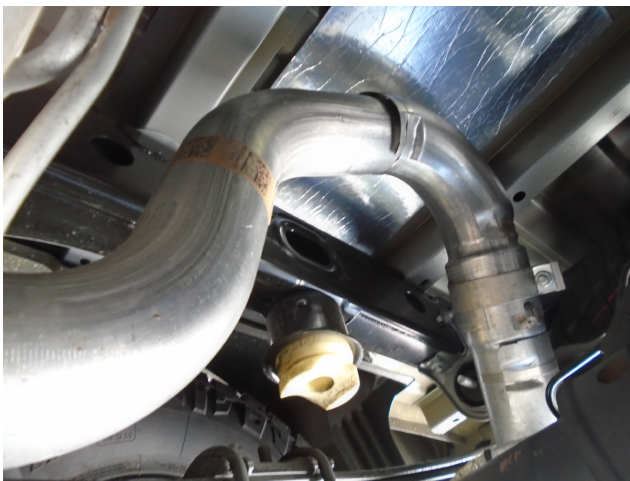
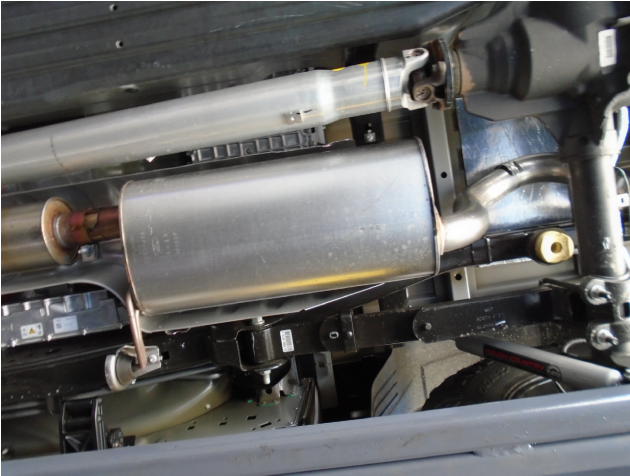

Step 1. To remove the OE exhaust system, loosen the clamp attaching the muffler to the resonator outlet pipe. With the system supported moving front to rear extract hangers from insulators. Do not discard the or damage the rubber insulators as they will be used to mount your new MAGNAFLOW system

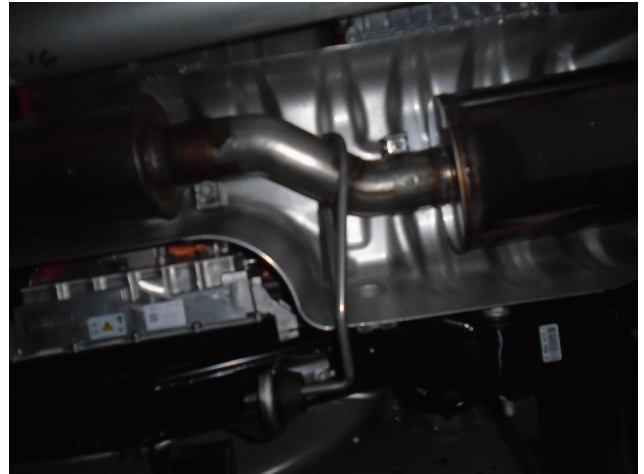

Step 2. Begin installing the new system by attaching the Inlet Pipe Assembly to the OE resonator outlet using the existing clamp. Locate the welded hanger to the rubber insulator. Leave all clamps and fasteners loose for final adjustment of the complete system once installed.

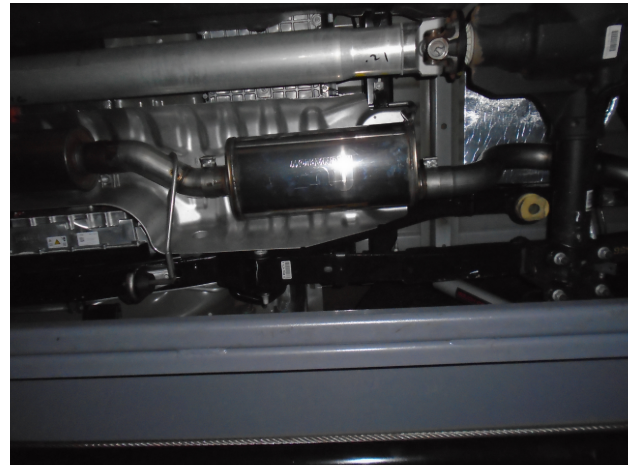

Step 3. Attach the Muffler Assembly to the Inlet Pipe Assembly with a supplied 3.00" clamp, fit the hanger into the rubber insulator.

INSTALLATION INSTRUCTIONS

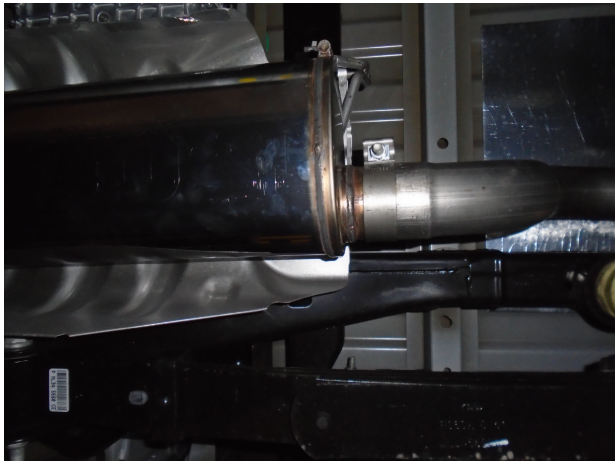

Step 4. Install the Over Axle Pipe using the supplied 3.00" clamp. Locate the welded hanger to the OEM rubber insulator.



Step 5. Finish installing the components by sliding the Tailpipe Assembly onto the Over Axle Pipe and fastening with a supplied 3.00" Clamp. Fit the hanger into the rubber insulator.



Step 6. Once a final position has been chosen for the new exhaust system, evenly tighten all clamps from front to rear using the torque specifications on page one of the instructions. Inspect all fasteners after 25-50 miles of operation and re-tighten if necessary.