

Any damaged or missing parts?

Parts will be shipped to you directly.

Call 800-206-4070 Mon - Fri, 8:30 a.m. - 5:00 p.m. CST
or email retrax@retrax.com

NOTE: Please read all instructions before assembling the bed cover.

Keep the boxes and packaging until the installation is complete. Unpack carefully to prevent scratching. **DO NOT** remove any protective films from the cover and canister until after the installation is complete. **DO NOT USE A LUBRICANT OR THREAD-LOCKER ADHESIVE ON THE ROLLING COVER.** USE OF THESE WILL VOID THE WARRANTY. See the maintenance page for proper care.

**Driver Side
Spiral Canister**

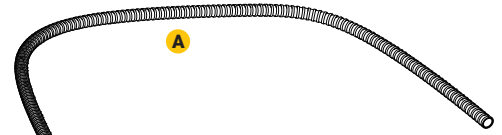

**ELECTRICAL PARTS
INCLUDED IN YOUR KIT**

- A** 1x Split wire loom
- B** 1x Fuse holder
- C** 2x 10 amp fuses
- D** 1x Wire harness
- E** 10x Wire ties
- F** 1x Electronics
- G** 1x LED lamp
- H** 2x Key fobs - transmitters
- I** 1x Electric cover accessory packet

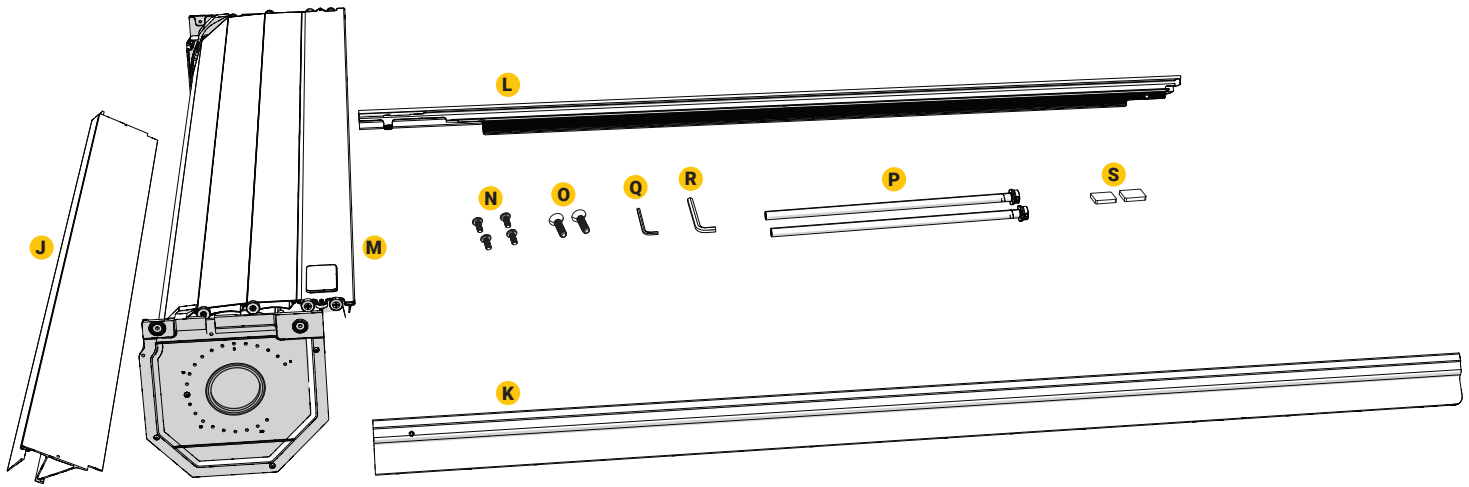
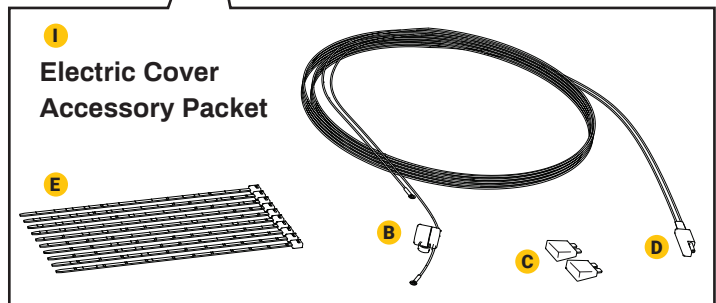
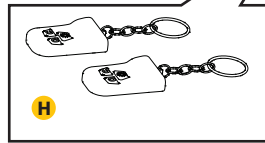

**COVER PARTS
INCLUDED IN YOUR KIT**

- J** 1x Front cover
- K** 1x Driver side rail
- L** 1x Passenger side rail
(Rail is designated by a green sticker)
- M** 1x Spiral canister
- N** 4x Canister mounting screws (10-32 x 7/16")
- O** 2x Front cover mounting screws (10-24 x 3/4")
- P** 2x Drain tubes
- Q** 1x 1/8" Allen wrench
- R** 1x 6mm Allen wrench
- S** 2x Bulkhead gasket (Only for 2016-2023)

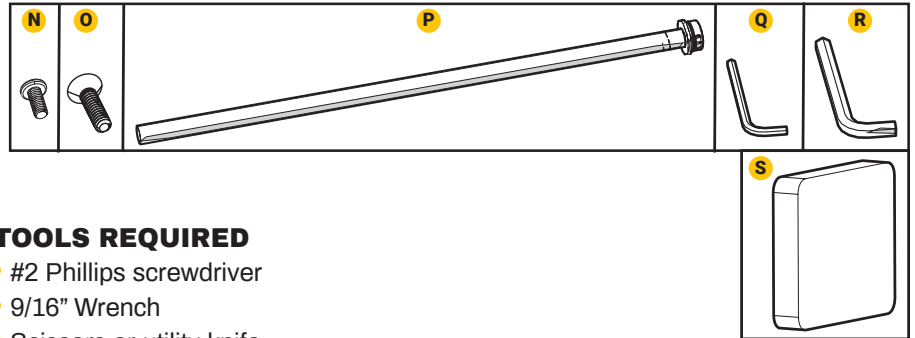

TOOLS REQUIRED

- #2 Phillips screwdriver
- 9/16" Wrench
- Scissors or utility knife
- Isopropyl alcohol

5' Model Parts

PARTS INCLUDED IN YOUR KIT

- T** 4x 0.050 Adjustment shim
- U** 4x Cleats
- V** 4x Mounting blocks
- W** 4x 1/4" Flat washer
- X** 4x Lock washer
- Y** 4x 1/4-28 x .75 Fastener
- Z** 4x 3/8-16 x 1.5 Fastener
- AA** 2x Foam pieces (Only for 2016-2023)
- JJ** 4x 3/8" Flat washer (Only for 2024+ 5' models)



TOOLS REQUIRED

- Isopropyl alcohol
- T-30 Torx bit
- 3/8" Drive short extension
- Ratchet
- 7/16" Wrench

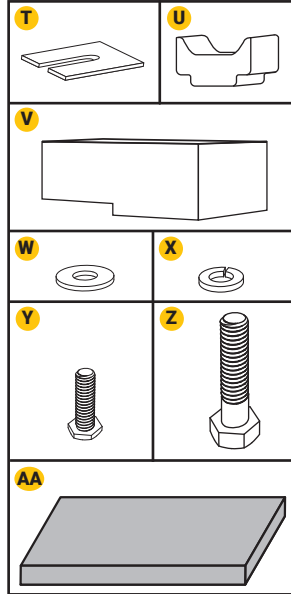

6' Model Parts

PARTS INCLUDED IN YOUR KIT

- BB** 4x 0.050 Adjustment shim
- CC** 4x Cleats
- DD** 4x Mounting blocks
- EE** 4x 1/4" Flat washer
- FF** 4x Lock washer
- GG** 4x 1/4-28 x 1.5 Fastener
- HH** 4x 3/8-16 x 1.5 Fastener
- II** 4x Plastic spacer blocks
- KK** 4x 3/8" Flat washer (Only for 2024+ 6' models)



NOTE:

Most parts above for 5' and 6' models are the same. Just lettered differently for install purposes. Parts (Y) and (GG) are different along with parts (AA) and (II).

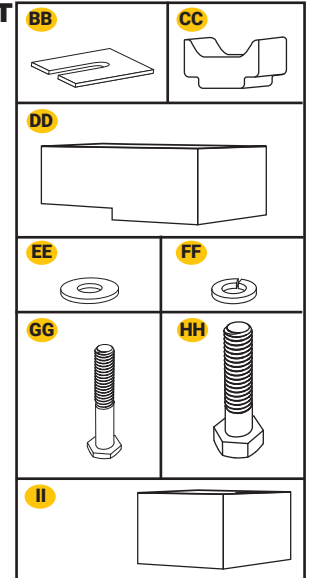

1 Routing wire harness from battery to truck bed:

Using a wire tie (E), secure the fuse holder (B) end of the wire harness (D) near the battery (red wire and brown wire). **Note: Do not connect the wiring harness (D) to your battery yet.**

2

Route the wire harness (D) to the driver side of the truck if it is not already. **Note: Using wire ties (E), secure the wiring harness (D) so it does not come into contact with moving parts or exhaust pipes.**

3

Route the wiring harness (D) down along the frame rails to the truck box as shown on the right. Keep the wires as high as possible to prevent damage while driving. Secure the wiring harness (D) with ties (E) every 2-3 feet.

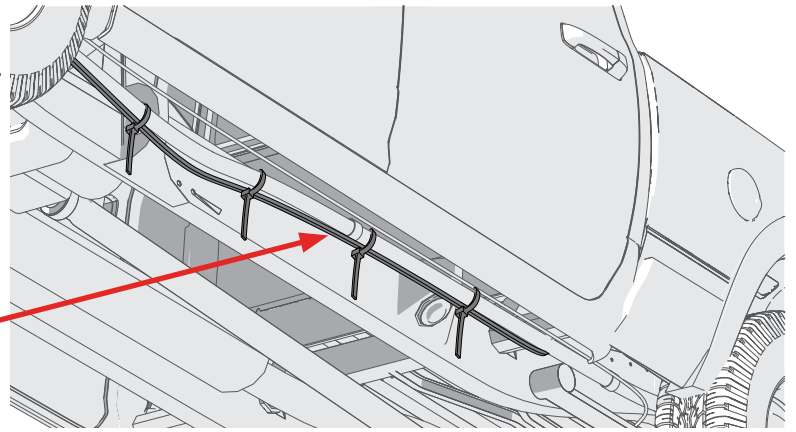

4 Wiring options:

Option 1:

Route the wiring (D) to the driver side drain hole in the truck bed (leave about 24" in truck bed). Use split wire loom (A) to wrap around the wires as a barrier between the wires and the drain tube hole.

Note: This may require a larger hole than normal.

Option 2:

Route the wiring (D) in the gap between the cab and truck bed leaving about 24" in the truck bed. The wires will be hidden under the front weather stripping of the Retrax cover.

Installing foam pieces is Only for the 2016-2023 5' models:

On the 5' model, there is an aluminum lip that sticks out the bottom of the canister (M). The supplied foam pieces (AA) are recommended to prevent scratches on your truck. With the edge of the cover facing you, roll the canister 90° away from you. The foam will line up with the rear-bottom fold. Remove the protective film from the foam. Then clean the area where the seal will go with soap and water to remove dirt and debris. Clean the area with isopropyl alcohol to remove wax or grease and to evaporate any remaining water. Allow the surface to dry. Remove adhesive backing and apply the foam to both sides. Apply pressure evenly to the entire seal to ensure proper adhesion.

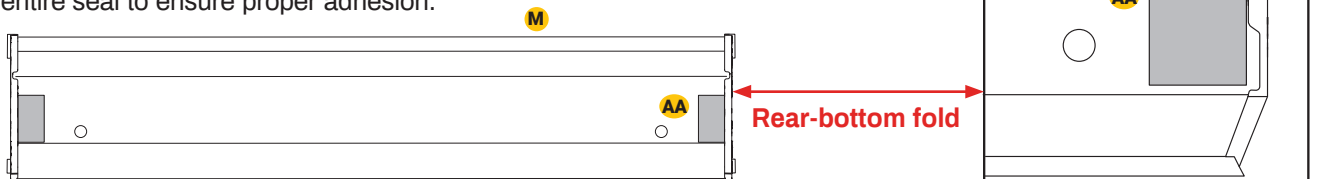

Removing the front tie-downs is Only for the 2016-2023 5' models:

Remove the front tie-downs in the bed. Use T-30 Torx.

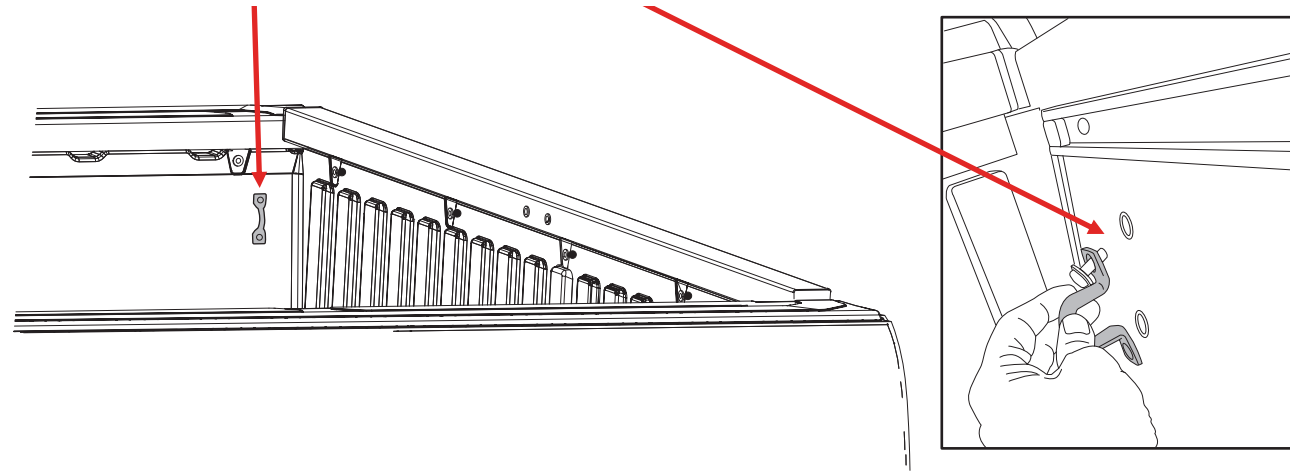

5 Installing seal is Only for the 2016-2023 5' models:

Remove factory cab header rail using a T-30 Torx driver to remove the (5) fasteners securing the header rail to the front of the bulkhead below the cab rear window. Clean both ends of the header rail with soap and water to remove dirt and debris. Clean the area with isopropyl alcohol to remove wax or grease and to evaporate any remaining water. Allow the surface to dry. Peel the backing and adhere the bulkhead gasket (S) to both ends of the header rail. Apply pressure evenly to the entire seal to ensure proper adhesion. Reposition header rail on truck bed and torque all mounting bolts to 7.5Nm (66.5 lbs-in).

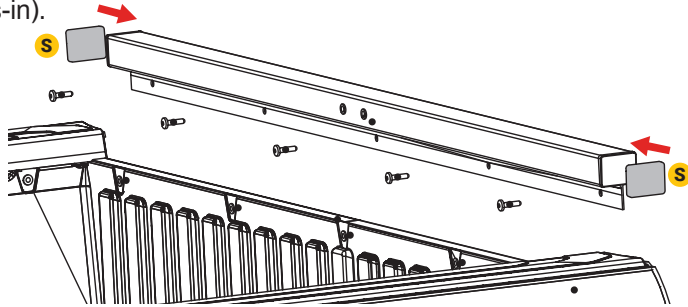

6 Insert mounting cleats:

Loosen and remove tie-downs or other accessories from each side. Insert (2) mounting cleats (U) for 5' models or mounting cleats (CC) for 6' models into the track system on each side.

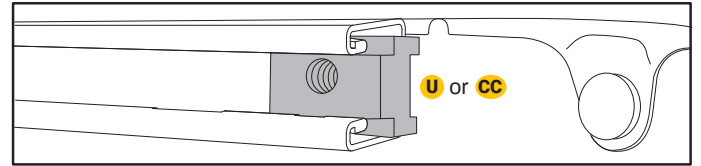

NOTE: The black plastic cap Only needs removed on 2024+ models before loosening and removing tie-downs.

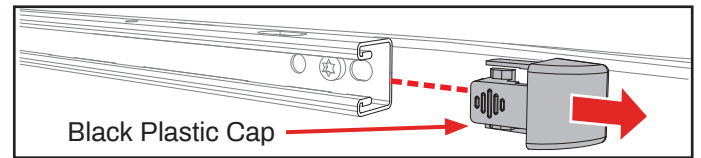

7 Bolt spacers to Retrax rails:

Mount spacer blocks prior to cover installation to truck bed. For 5' models use the 1/4-28 x .75L fastener (Y) and 1/4" flat washer (W) on the inside of the Retrax rail and cleat on the outside or For 6' models use the 1/4-28 x 1.5L fastener (GG) and 1/4" flat washer (EE) on the inside of the rail and spacer block and cleat on the outside. Attach with 7/16" wrench.

5' Model Parts

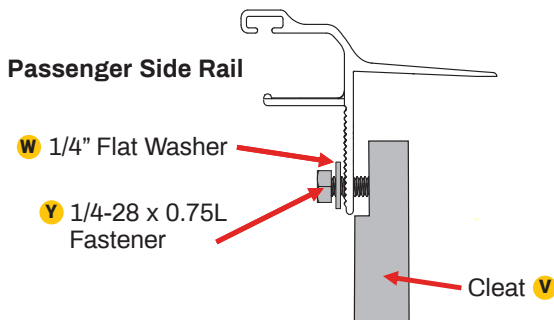

6' Model Parts

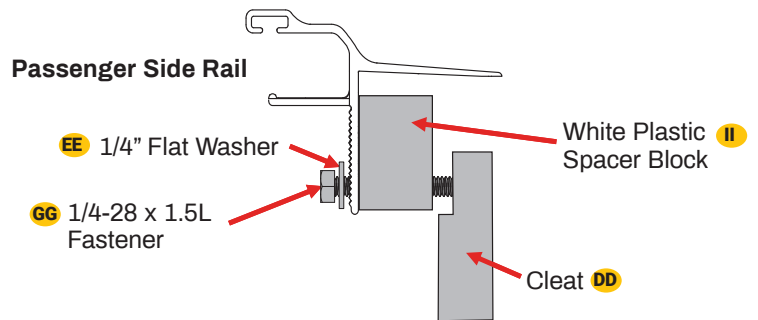

8 Remove shipping materials:
Remove the screws, shipping brackets and the white shipping tubes from both sides. Retain a shipping bracket for later use as a shim.

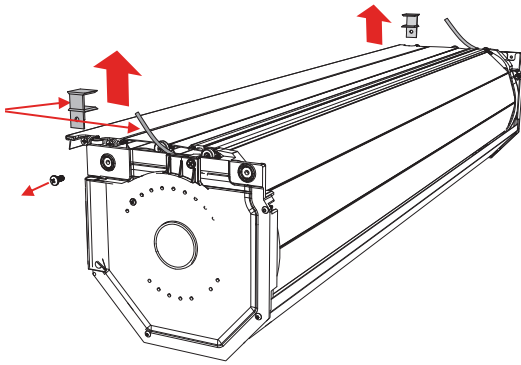

9 Install the rails to the canister:
Pull the cover out of the canister (M) 6 to 8 inches, holding it from rolling back in, guide the cover into the rail (K & L) channel while positioning the rails into the canister (M). Align the front and rear rail attachment tabs and holes to the inside of the corresponding canister holes. **K**

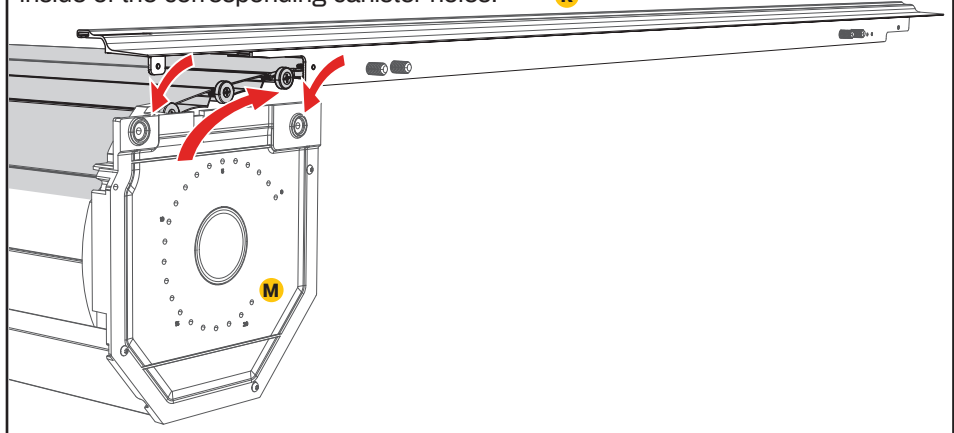

10 Fasten the rails to the canister:
With the rails in place and the cover slid into the rail channel, attach the rails with the four 10-32 x 7/16" canister mounting screws (N).

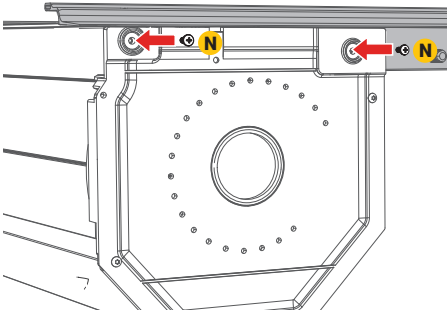

Tighten the canister mounting screws to: 32 in-lbs.

11 Install the front cover:
Slide the front cover (J) under the rails (K & L), attaching it with the two 10-24 x 3/4" front cover screws (O) with the 1/8" Allen wrench (Q). The front cover attaches through the top of the rail.

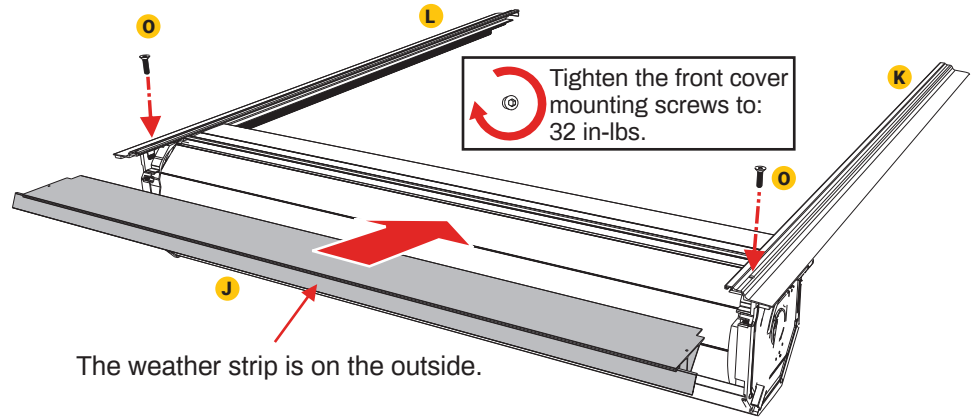

12 Prepare the bed for cover installation:
NOTE: Prior to installing the cover, some drop-in style bed liners may need to be notched in the front/cab end corners to provide clearance for the cover canister.

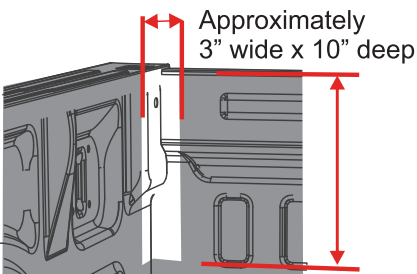

Also ensure that protrusions or logos in the drop-in liner do not interfere with the cover's operation.

13 Position the cover:
With two people, lift the cover and place it onto the truck bed starting by placing the canister (M) portion near the bulkhead. The front seal of the cover should lay forward and lay flat.

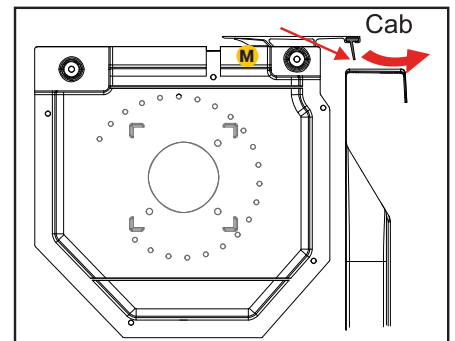

NOTE: With the cover in place, the front seal lays flat on the bulkhead, but must not extend past the bed rail cap. Trim the seal as needed to ensure that it lays flat.

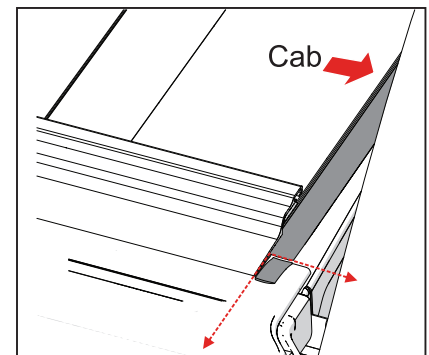

14 **Position the rails:** Move the cover back toward the tailgate and use the shipping bracket as a spacer to position both rails to be 1/8" from the tailgate.

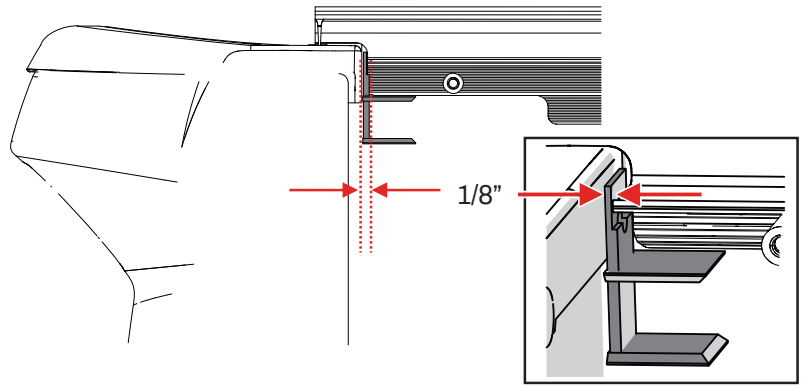
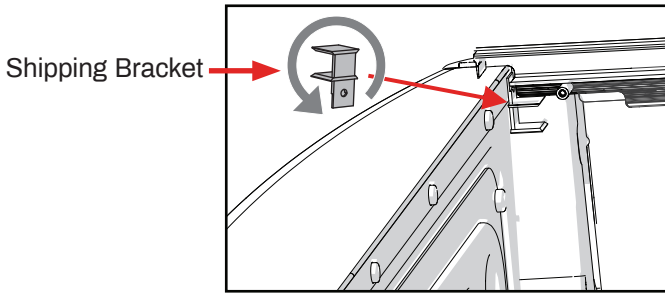

15 **Bolt rails to truck bed rails:**

5' Model (Passenger Side Rail)

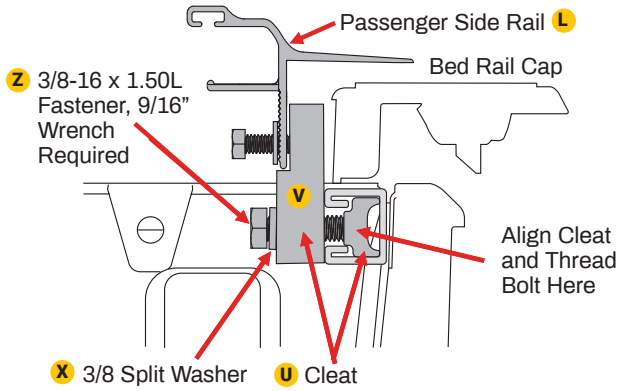

6' Model (Passenger Side Rail)

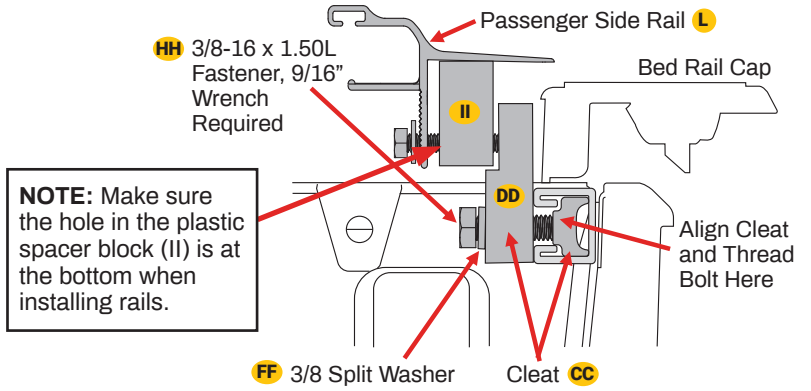

2024+ 5' Models Get Extra Flat Washer (Passenger Side Rail)

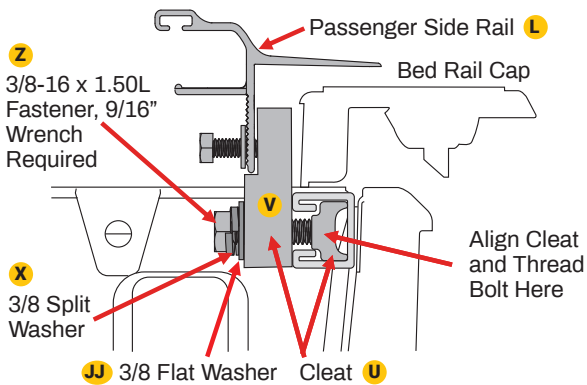

2024+ 6' Models Get Extra Flat Washer (Passenger Side Rail)

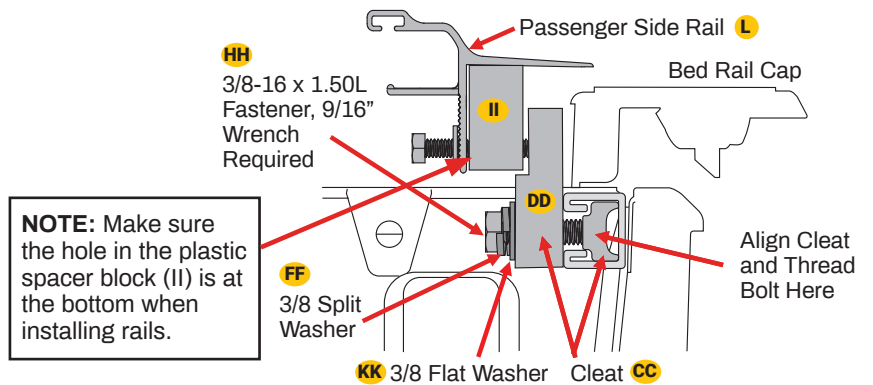

16 **Adjust rails to maintain parallel rails:**

If rails are too far apart add 0.050 shim (T) for **5' models** or (BB) for **6' models** between rail and aluminum spacer. Continue adjustment until rails are parallel.

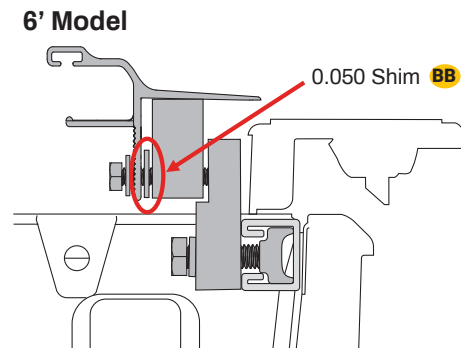
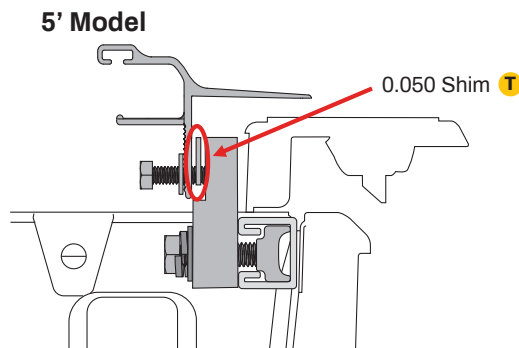

17 Measure and record the distance between the rails

- 17a.** Measure the distance at point A (on top of the front cover).
17b. Then measure the distance at points B & C (above each clamp). They must measure the same $\pm 1/16"$ as at point A.
17c. If the measurements are correct, proceed to step 18.

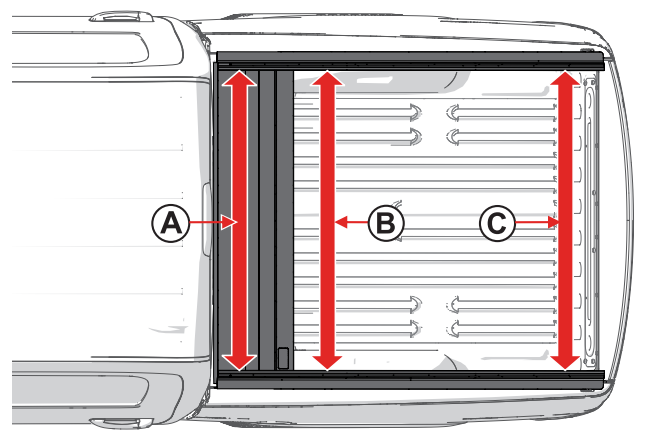

18 Check for proper fit between the front cover and the rolling cover:

- With the cover closed and latched, if there is less weatherstrip exposed on one side versus the other then adjust that rail more forward and toward the cab. Loosen the clamps and move the rail. Check again for equal spacing, adjust as necessary then tighten all the clamps per step 15 & 16.

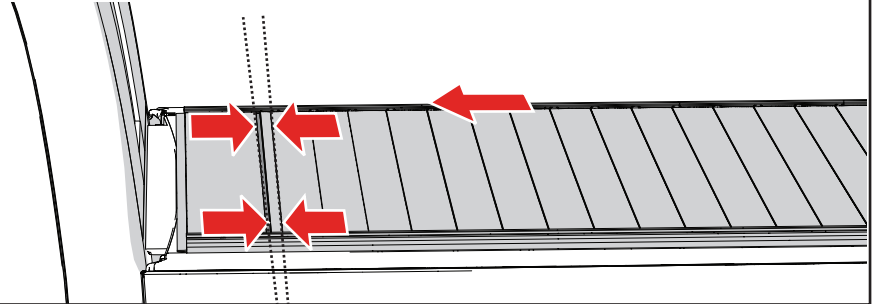

19 Install the drain tubes:

- 19a.** Insert the drain tube (P) into the canister (M) on both sides, rotate to the right, clockwise, the fitting will click twice when secure. **19b.** Generally the drain tubes (P) will be routed out through a hole drilled in the factory bed plug. Otherwise a suitable existing hole must be utilized. Or a new hole can be drilled, **taking great caution to be aware of lines and anything behind where the hole is drilled.**

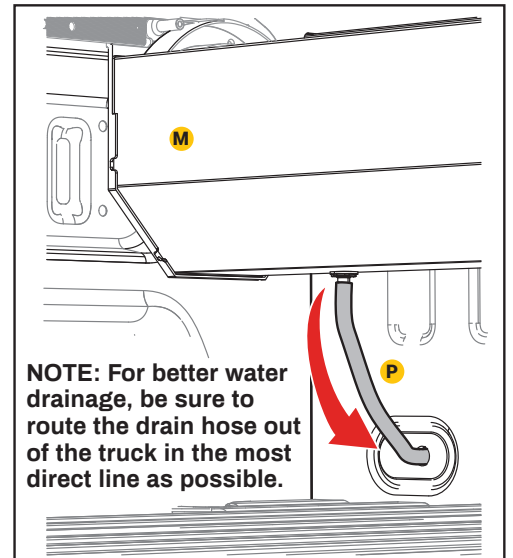
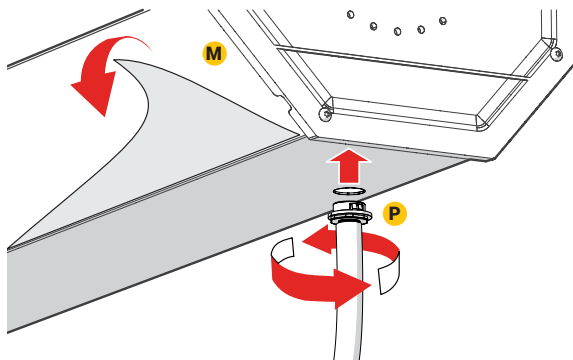

NOTE: For better water drainage, be sure to route the drain hose out of the truck in the most direct line as possible.

20 Connect the wiring harness to electronics box and battery:

- A.** Connect the power harness to the connector with a white label with the letter "P" on it for Power. Ensure the connectors are securely connected. (Connectors labeled with the letter "M" for Motor will come attached.)
B. Connect the wires to the battery and install a fuse (C) in the fuse holder (B). Connect the RED wire (with the fuse holder) to the POSITIVE post and the BROWN wire to the NEGATIVE post.

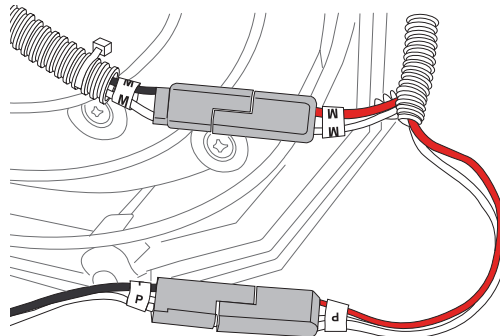

Operation of the POWERTRAX

- Hold to open → O C → Hold to close
- Press once to illuminate light (auto shut off after 3-5 minutes)

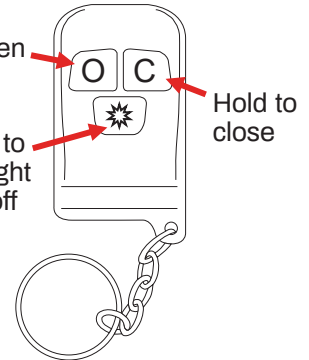

For proper cover operation, ensure rails are positioned correctly (must be parallel). See steps 15 & 16.

These surfaces must be level.

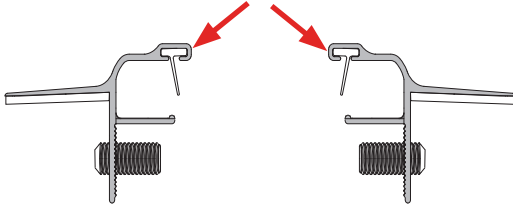

This device complies with Part 15 of the FCC Rules. Operation is subject to the following two conditions: (1) this device may not cause harmful interference, and (2) this device must accept any interference received, including interference that may cause undesired operation.

FINAL NOTES

- Open and close the cover to ensure that it is rolling without rubbing or binding.
- Open and close the tailgate to check for proper movement.
- On some models, a better fit with the tailgate may be obtained if the rear of the rails are adjusted slightly up or down.
- Remove all remaining protective film.
- Recheck that all of the clamps are tight.

Do this periodically throughout the use of the cover.

- Check that the rails are level and spaced evenly, and adjust accordingly.



Remove any snow or foreign matter before operating cover.

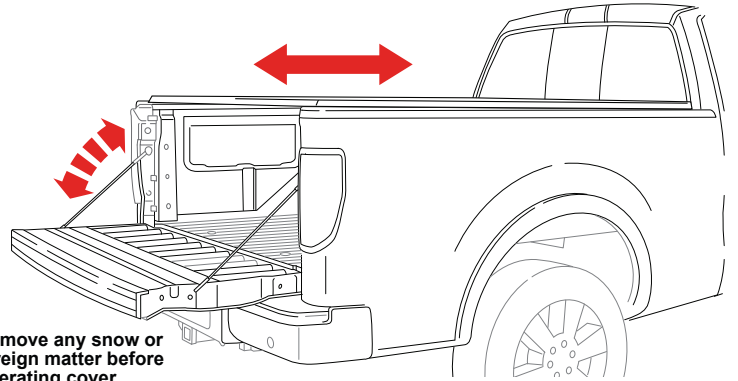

XR Trax Rail System Only - Rack System Installation Information

Truck Owners Manual



Be sure to refer to the truck owner's manual for load ratings for the truck. When calculating weight of cargo, be sure to include occupants and the Retrax cover.

Retrax cover with rack system= 125lbs.

Rack System



For installation instructions and load ratings for the rack system, refer to the rack system's manual.

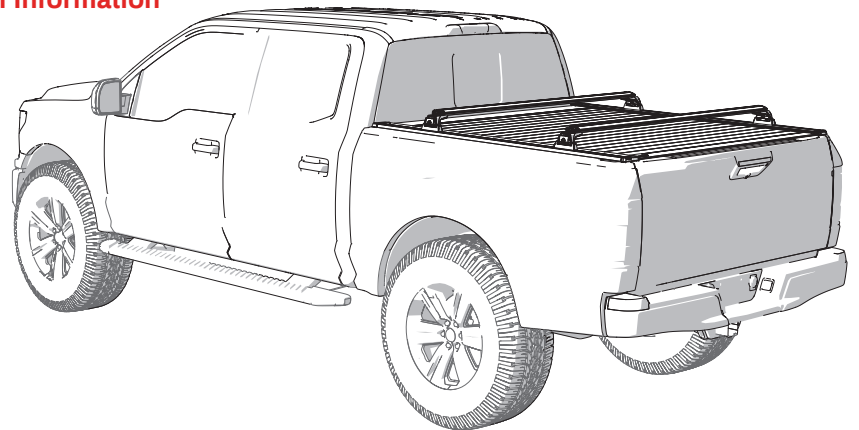

CAUTION



To prevent damage or loss of cargo when driving, check to make sure cross bars and cargo are securely fastened. Loading cargo on the roof rack will make the vehicle's center of gravity higher. Avoid high speeds, sudden starts, sharp turns, sudden braking or abrupt maneuvers; otherwise, it may result in a loss of control. If driving for a long distance on rough roads, or at high speeds, occasionally stop the vehicle and make sure the cargo remains in its place. Do not ever exceed the maximum vehicle capacity when loading the vehicle.



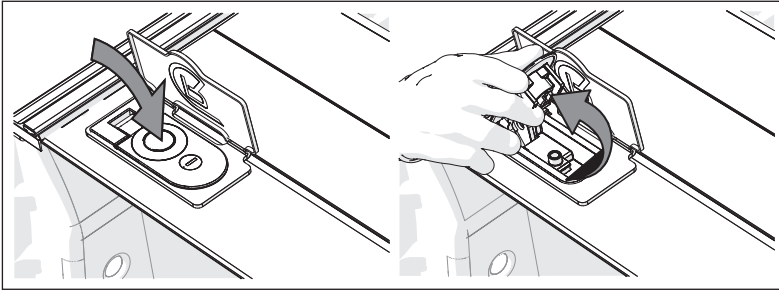

USE

Opening and using the cover

To use your cover, open the lock cover and press the button at the center of the latch to pop open the handle.

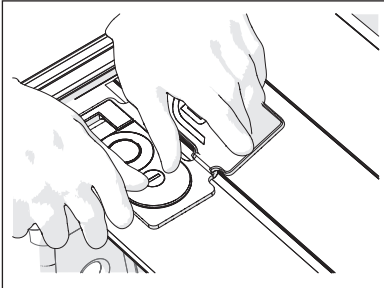

Closing and locking the cover

To latch your cover anywhere along the rail, push down firmly on the end of the lock handle. Insert the key and turn until it is locked or unlocked.

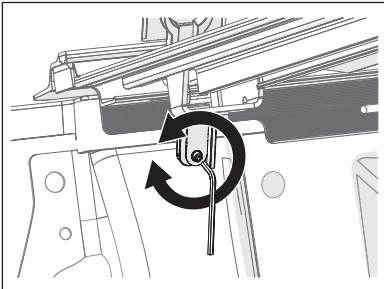

Lock cover adjustment

A 3/32" Allen wrench can be used to adjust the pointed set-screw on the lock arm. Turn clockwise to increase latching pressure on the rail, or turn counter-clockwise if the lock is too hard to close.

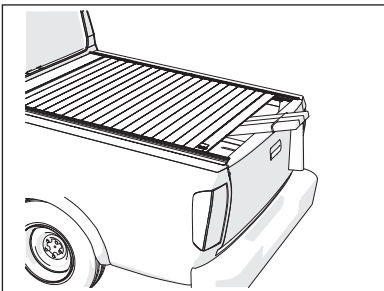

Securing loose cargo

Retractable covers help in transporting loose and large cargo, a unique feature that most bed covers cannot claim. **NOTE:** Cargo should still be secured to the truck bed to prevent it from coming loose.

To help secure any item too big to fit under the cover, latch the lock handle shut against the item to help keep it in place.

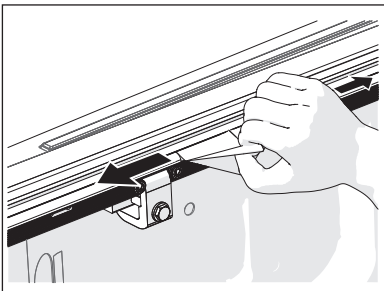

MAINTENANCE & CARE

Cleaning and caring for your cover.

You can wash the cover, but do not use any cleaners, protectants or strong chemicals.

The cover should be cleaned with mild soap and water.

Do not allow gasoline to come in contact with the cover.

The weather stripping may absorb soapy residue from a car wash, it is recommended to wipe down the inside of the rails from time to time.

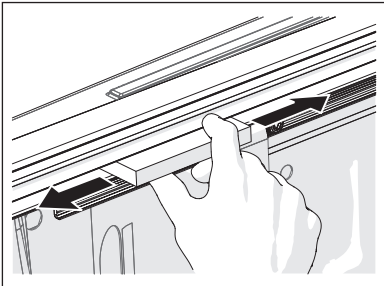

IMPORTANT: NEVER spray any lubricant or cleaner in the rails. THIS WILL VOID THE WARRANTY.

The bearings are sealed and will not need any lubricant or spray. If the rails feel sticky, run paraffin wax along the rail.

COVER CARE AND MAINTENANCE

Clean with mild automotive soap and water only. Do NOT use any strong chemicals or cleaners. Do not allow gasoline to come in contact with the cover.

DO NOT wax your Retrax cover. The weather-stripping on your cover may absorb soapy residue from a car wash, so we recommend wiping down the inside of your rails from time to time.

IMPORTANT: NEVER spray any lubricant or cleaner on the rails. THIS WILL VOID YOUR WARRANTY. The ball bearings are sealed and will not need any lubricant or spray. If the rails feel a little 'sticky', you may rub some Paraffin (candle) wax along them until they wear in.

It is recommended that you periodically check that the cover is securely attached to your truck bed. Inspect the clamps and front mounting bolts to ensure they were properly installed and have not come loose or knocked out of adjustment during operation. Covers that are used with high frequency or that are subject to the vibrations and impact from rough roadways can cause the cover to require adjustment.

USE

OPENING AND USING THE COVER

To use your RETRAX cover, open the lock cover and press the button at the center of the latch to pop open the handle.

CLOSING AND LOCKING THE COVER

To latch your RETRAX cover anywhere along the rail, push down firmly on the end of the lock handle using both thumbs. Insert the key and make sure it locks and unlocks.

SECURING LOOSE CARGO

RETRAX covers help transport loose and large pieces of cargo safely and securely; a unique feature that most tonneau covers cannot claim. To help secure any item too big to fit under the cover, latch the lock handle shut against the item to keep it in place.

SAFETY INSTRUCTIONS

- DO NOT tow your vehicle from the rear with the cover on your vehicle. If towing from the rear is required, the cover MUST be removed from the vehicle and properly stored.
- DO NOT allow gasoline to come in contact with the cover.
- All large and heavy cargo must be secured by straps.
- NEVER allow children or pets to occupy the truck bed while the cover is closed.
- The cover is not airtight. Special care is required to keep cargo clean and dry.
- Tonneau covers won't prevent theft of contents inside the truck box.

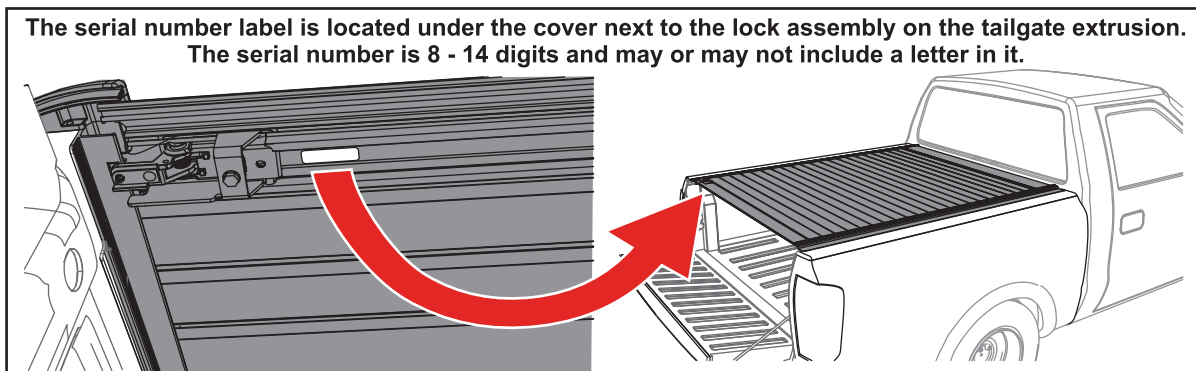

LIMITED WARRANTY

WARRANTY COVERAGE

This truck bed cover is warranted against defects in materials or workmanship as follows. This warranty is void if the product has been damaged in an accident, or due to neglect, unforeseeable use, improper installation, improper servicing, or other cause not arising out of defects in material or workmanship.

Powertrax - The truck bed covers carries a limited warranty for **three (3) years** from the original date of purchase, subject to the terms below.

WARRANTY IS NOT TRANSFERABLE

The warranty is to the initial consumer purchasing the truck bed cover and it is not transferable to a subsequent end user. Proof of purchase may be required to enforce these warranty rights.

WARRANTY CONDITIONS

Failure to follow these care and use instructions will void the warranty:

- Clean with mild automotive soap and water only. Do not use any strong chemicals or cleaners. Lubrication of the rails or sealed ball bearings will void the warranty.
- Cargo must be secured at all points when the vehicle is in motion. Failure to adequately secure the cover or tether strap can result in damage and will void the warranty.
- Check all clamps and retention mechanisms for tightness after a week of driving following installation (or re-installation) of the cover and periodically thereafter.
- Before opening, the cover must be free of all foreign materials including snow and ice.
- DO NOT tow your vehicle from the rear with the cover on your vehicle. If towing from the rear is required, the cover MUST be removed from the vehicle and properly stored.

WARRANTY PERFORMANCE

If all warranty conditions are met, a defective truck bed cover or hardware component will either be repaired or replaced (at our option). We reserve the right, for any warranty, to substitute a newer model or bed cover having a similar form and function, to offer a warranty discount on an entire replacement system, and/or provide remedies other than those mentioned in this document.

WARRANTY RETURN

A Return Material Authorization number must be obtained from our Customer Service Department prior to returning any product. We may require the original item to be returned postage prepaid for final determination. Shipping charges will apply for any repair or replacement. Other than postage or shipping charges, no charge will be made for repair or replacement under this warranty.

This warranty gives you specific legal rights. As a consumer, you may also have additional rights and remedies under the laws of your state.

Register online at <https://realtruck.com/retrax-warranty>.

**REGISTER
YOUR
WARRANTY
ONLINE**

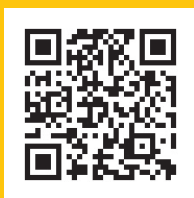

Serial Number _____

Date of Purchase _____

