

Installation Instructions

Jeep Wrangler JK Unlimited

I-88737 RevA



Trail Crawler Step

For proper installation and best possible fit, please read all instructions **BEFORE** you begin.
For technical assistance or to obtain missing parts, please call Customer Relations at 1-800-328-2409.

Important Safety Information



- CAUTION - Before driving, ensure that the steps are properly secured to vehicle.
- Periodically check all components for tightness.

Contents

NOTE: Actual product may vary from illustration.

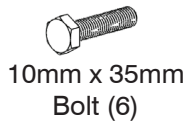
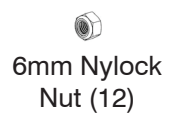
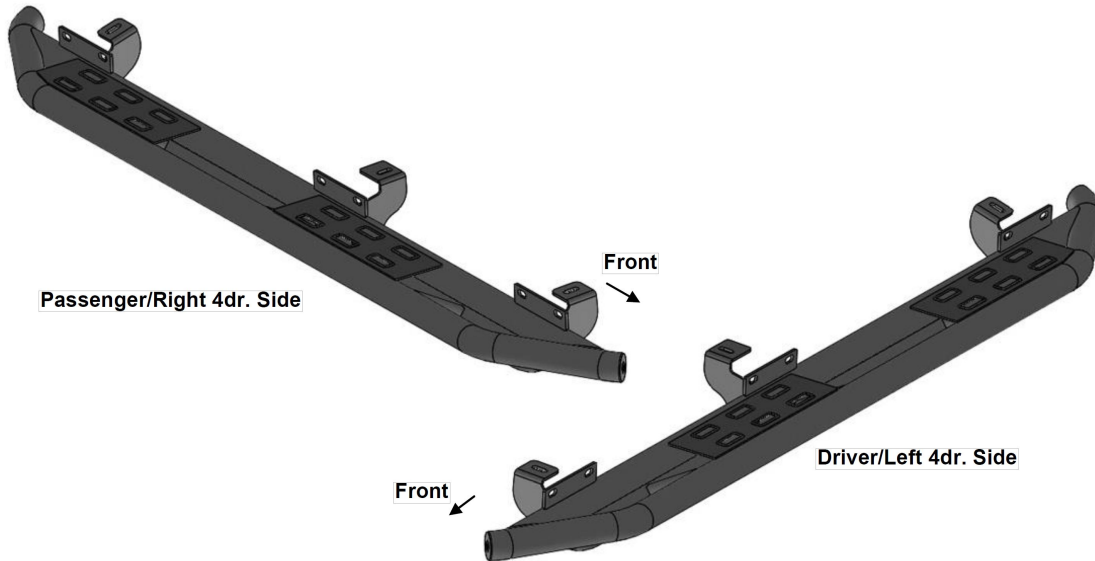

10mm Nut Plate
(6)
(2007-10 use only)

Tools Required

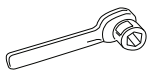

Socket
Wrench



Socket (Set)

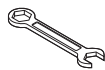

18mm Wrench



Safety glasses

Installation

1 Start installation on the passenger side of the vehicle. Locate the (3) factory pairs of mounting holes along the pinch weld, (Figure 5). The mounting brackets on the Trail Crawler attach to the holes in the pinch weld and the small hole directly behind the pinch weld.

2 Determine if the vehicle has an open floor panel, (2007-10, Figure 1), or threaded holes in the floor panel, (2010-15, Figure 2), for the top tab on the Bracket.

Vehicles with open mounting locations along floor panel:

- a. Move to the front pair of holes in the pinch weld. Locate the mid point between the two holes, (Figure 3). insert (1) 10mm Nut Plate into the large square opening in the floor panel, (Figures 4A & 4B). Line up the threaded nut with the small hole directly in line with the mid point, (Figure 3).
- b. Repeat to install the 10mm Nut Plate as required in any/all locations.

Figure 1

2007-10 driver side front mounting location

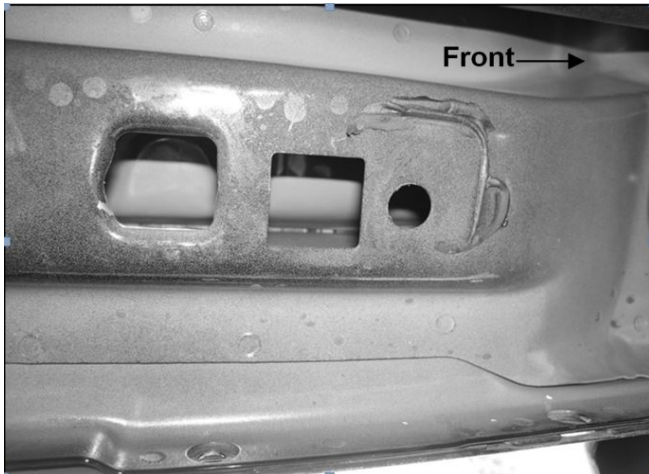

Figure 2

Example of 2010-15 "closed" floor panel with 8mm threaded hole-10mm Nut Plate not required

Vehicles with threaded hole in body panel use:

Vehicles with threaded hole in body panel use: 8mm x 35mm Hex Bolt
8mm Lock Washer
8mm Flat Washer



Figure 3

2007-10 driver side rear mounting location pictured from below. Locate the holes in the pinch weld first to determine correct mounting hole for 10mm Nut Plate

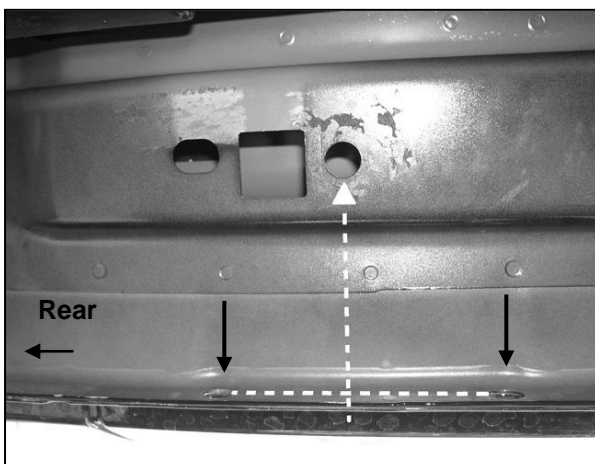

Figure 4A

10mm Nut Plate



Figure 4B

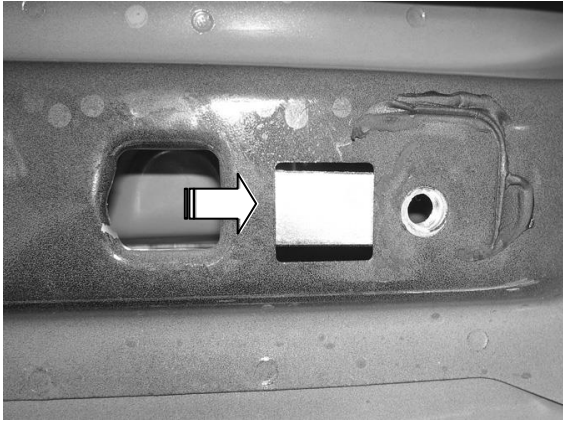
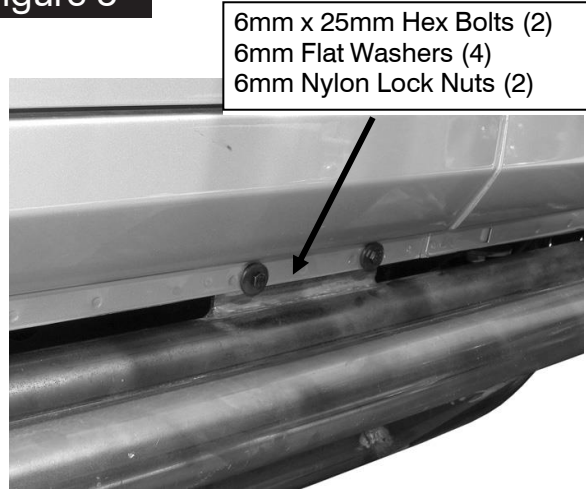

Figure 5



3

With assistance, hold the passenger Trail Crawler up in place against the back of the pinch weld. Line up the (3) brackets with the (6) factory holes in the pinch weld. Bolt the brackets to the back of the pinch weld with the included (6) 6mm x 25mm Hex Bolts, (12) 6mm Flat Washers and (6) 6mm Nylon Lock Nuts, (Figures 5 & 6). Leave hardware loose at this time.

4

Bolt each top tab on the Trail Crawler to the vehicle:

- a. Models with "open floor" requiring 10mm Nut Plate, attach each bracket to the Nut Plate with (1) 10mm x 35mm Hex Bolt, (1) 10mm Lock Washer and (1) 10mm Flat Washer, (Figures 4B, 6 & 7). Repeat for any/all mounting locations.
- b. Models with 8mm threaded factory holes, attach each bracket with (1) 8mm x 35mm Hex Bolt, (1) 8mm Lock Washer and (1) 8mm Flat Washer, (Figures 2, 6 & 7). Repeat for any/all locations.

Figure 6 Passenger side front installation illustrated

6mm x 25mm Hex Bolt (2)
6mm Flat Washers
6mm Nylon Lock Nut

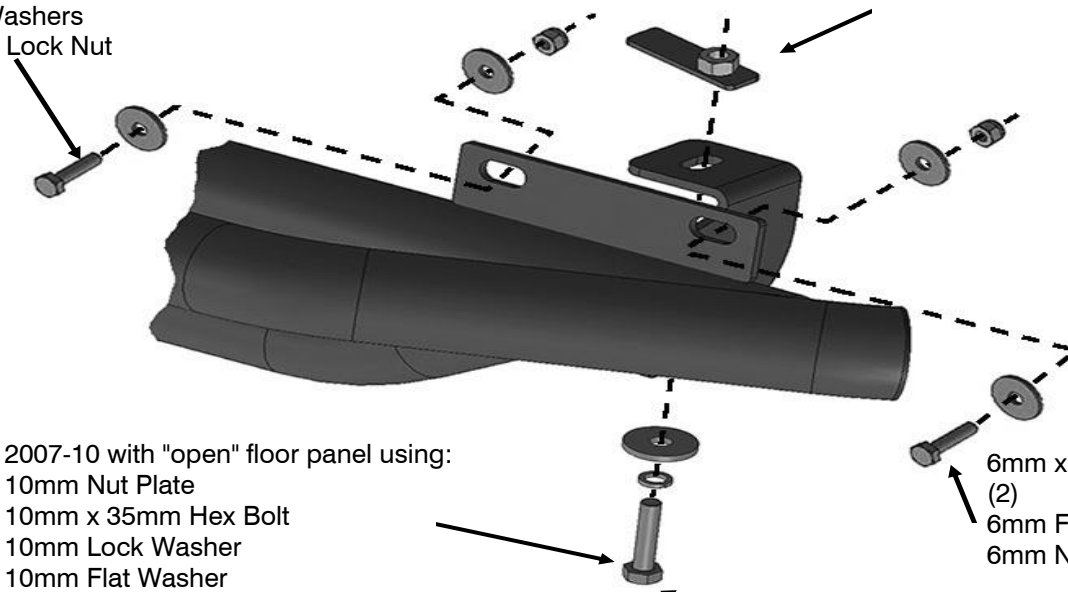

2007-10 with "open" floor panel use 10mm Nut Plate

2007-10 with "open" floor panel using:
10mm Nut Plate
10mm x 35mm Hex Bolt
10mm Lock Washer
10mm Flat Washer

6mm x 25mm Hex Bolt (2)
6mm Flat Washers
6mm Nylon Lock Nut

2010-15 vehicles with threaded hole in floor panel use:
8mm x 35mm Hex Bolt
8mm Lock Washer
8mm Flat washer

5

Level and adjust the Trail Crawler and tighten all hardware.

6

Repeat Steps 2-6 for driver side Trail Crawler installation.

Figure 7

Passenger side front installation illustrated



Complete Installation



Care and Cleaning

- Rampage products are built to last; any detergent you use to wash your vehicle is sufficient to clean the bumper. Do not use any harsh abrasive detergents. Periodically check and lubricate moving parts.

Congratulations!

You have purchased one of the many quality Rampage branded products offered by Lund International. We take the utmost pride in our products and want you to enjoy years of satisfaction from your investment. We have made every effort to ensure that your product is top quality in terms of fit, durability, finish and ease of installation.



The material that your product is made from can be recycled. Please also consider recycling the packaging that your product came in.



800-328-2409 • Visit us at Rampageproducts.com
© 2018 Lund Motion Products, Inc. All rights reserved.
Rampage Products™ is a trademark of Lund Motion Products, Inc.

