

SKYJACKER

SUSPENSIONS

SKYJACKER.COM

1994-2001 Dodge Ram 1500 4WD
 1994-2002 Dodge Ram 2500 4WD
 1994-2002 Dodge Ram 3500 4WD

HD OEM Replacement Steering Stabilizer Kit Installation Instructions

Required Tools List:

- SAE Sockets \ Wrenches (11/16" & 3/4")
- Metric Sockets \ Wrenches
- Diagonal Cutting Pliers
- Safety Glasses
- Wheel Chock
- Torque Wrench



Before beginning the installation, read these instructions thoroughly & completely. Please refer to the Parts List to insure that all parts & hardware are received prior to disassembly of the vehicle. If any parts are found to be missing, contact SKYJACKER® Customer Service at 318-388-0816 to obtain the needed items. If you have any questions or reservations about installing this product, contact SKYJACKER® Technical Assistance at 318-388-0816.

Component Box Breakdown:

Part # 2007

Item #	Description	Qty
2000AS	ADX HD STEERING DAMPER, ALU	1
ADXSD	DECAL, ADX 2.0 STABILIZER	1
HB-8007	HDWR BAG: 2007 / 8007 STAB.	1

Part # 7007

Item #	Description	Qty
7000WS	STEERING DAMPER, WHITE	1
B10RS	BOOT STABILIZER, RED	1
BTIE	BOOT CABLE TIE, RED	1
HYDRO 6X2-CL	DECAL, HYDRO STABILIZER	1
HB-7007	HDWR BAG: 7007 / 9007 STAB.	1

Part # 8007

Item #	Description	Qty
8000BS	STEERING DAMPER, BLACK	1
B10KS	BOOT STABILIZER, BLACK	1
BTIE-K	BOOT CABLE TIE, BLACK	1
MXSD	DECAL, BLACK MAX STABILIZER	1
HB-8007	HDWR BAG: 2007 / 8007 STAB.	1

Part # 9007

Item #	Description	Qty
9000WS	STEERING DAMPER, SILVER	1
B10KS	BOOT STABILIZER, BLACK	1
BTIE-K	BOOT CABLE TIE, BLACK	1
SSD	DECAL, SILVER STABILIZER	1
HB-7007	HDWR BAG: 7007 / 9007 STAB.	1

Hardware Bag Breakdown:

Part # HB-8007

Item #	Description	Qty
HG5815-K	HOURGLASS, 5/8 X 1.50, BLACK	2
P837	TAPERED STUD MOUNT, 141264	1
141509	ES25 SLEEVE, 1.50 LONG	1
142121	ES24 SLEEVE, 1.38 LONG	2
12X312FTB	1/2 X 3-1/2 FINE THREAD BOLT	1
12X4FTB	1/2 X 4 FINE THREAD BOLT	1
12FTN	1/2-20 FINE THRD N/I LOCK NUT	2
12SAEW	1/2 SAE WASHER	2
81004	TAPERED SLEEVE, 1/2 I.D.	1
58SP	SPACER, 5/8 I.D. X 1-1/4 O.D.	1

Part # HB-8017

Item #	Description	Qty
HG5815-K	HOURGLASS, 5/8 X 1.50, BLACK	2
141509	ES25 SLEEVE, 1.50 LONG	3
142121	ES24 SLEEVE, 1.38 LONG	2
12X312FTB	1/2 X 3-1/2 FINE THREAD BOLT	1
12X4FTB	1/2 X 4 FINE THREAD BOLT	1
12FTN	1/2-20 FINE THRD N/I LOCK NUT	2
12SAEW	1/2 SAE WASHER	2
12USSW	1/2 USS WASHER	1
81004	TAPERED SLEEVE, 1/2 I.D.	1
58SP	SPACER, 5/8 I.D. X 1-1/4 O.D.	1

Component Box Breakdown:**Part # 2017**

Item #	Description	Qty
2000AS	ADX HD STEERING DAMPER, ALU	1
ADXSD	DECAL, ADX 2.0 STABILIZER	1
HB-8017	HDWR BAG: 2017/8017 STAB.	1

Part # 7017

Item #	Description	Qty
7000WS	STEERING DAMPER, WHITE	1
B10RS	BOOT STABILIZER, RED	1
BTIE	BOOT CABLE TIE, RED	1
HYDRO 6X2-CL	DECAL, HYDRO STABILIZER	1
HB-7017	HDWR BAG: 7017/9017 STAB.	1

Part # 8017

Item #	Description	Qty
8000BS	STEERING DAMPER, BLACK	1
B10KS	BOOT STABILIZER, BLACK	1
BTIE-K	BOOT CABLE TIE, BLACK	1
MXSD	DECAL, BLACK MAX STABILIZER	1
HB-8017	HDWR BAG: 2017/8017 STAB.	1

Part # 9017

Item #	Description	Qty
9000WS	STEERING DAMPER, SILVER	1
B10KS	BOOT STABILIZER, BLACK	1
BTIE-K	BOOT CABLE TIE, BLACK	1
SSD	DECAL, SILVER STABILIZER	1
HB-7017	HDWR BAG: 7017/9017 STAB.	1

Hardware Bag Breakdown:**Part # HB-7017**

Item #	Description	Qty
HOURGLASS 5/8	HOURGLASS, 5/8 X 1.50, RED	2
141509	ES25 SLEEVE, 1.50 LONG	3
142121	ES24 SLEEVE, 1.38 LONG	2
12X312FTB	1/2 X 3-1/2 FINE THREAD BOLT	1
12X4FTB	1/2 X 4 FINE THREAD BOLT	1
12FTN	1/2-20 FINE THRD N/I LOCK NUT	2
12SAEW	1/2 SAE WASHER	2
12USSW	1/2 USS WASHER	1
81004	TAPERED SLEEVE, 1/2 I.D.	1
58SP	SPACER, 5/8 I.D. X 1-1/4 O.D.	1

Part # HB-8017

Item #	Description	Qty
HG5815-K	HOURGLASS, 5/8 X 1.50, BLACK	2
141509	ES25 SLEEVE, 1.50 LONG	3
142121	ES24 SLEEVE, 1.38 LONG	2
12X312FTB	1/2 X 3-1/2 FINE THREAD BOLT	1
12X4FTB	1/2 X 4 FINE THREAD BOLT	1
12FTN	1/2-20 FINE THRD N/I LOCK NUT	2
12SAEW	1/2 SAE WASHER	2
12USSW	1/2 USS WASHER	1
81004	TAPERED SLEEVE, 1/2 I.D.	1
58SP	SPACER, 5/8 I.D. X 1-1/4 O.D.	1

Pre-Installation Tips: Install Stabilizer Boot, Bushings & Sleeves.

1. Install supplied Stabilizer Boot over Skyjacker Steering Stabilizer. Attach boot to cylinder body with supplied Boot Cable Tie. Remove excess cable tie with diagonal cutting pliers.
2. Coat Hourglass Bushings with a water resistant grease & press into Each Stabilizer Eye.

With OEM Pitman Arm: 1994-1997 Ram 1500. 1994-1997 Ram 2500 / 3500. Coat 1.50" Steel Sleeve with a water resistant grease & press into Cylinder Body Eye Bushing Only.

With OEM Pitman Arm: 1998-2001 Ram 1500. 1998-2002 Ram 2500 / 3500. Coat 1.38" Steel Sleeve with a water resistant grease & press into Each Stabilizer Eye Bushing.

With Lift & Drop Pitman Arm: 1998-2001 Ram 1500. 1994-2002 Ram 2500 / 3500 Coat 1.50" Steel Sleeve with a water resistant grease & press into Each Stabilizer Eye Bushing.

Installation: Note: Save all factory components & hardware for reuse, unless noted.

1. Chock rear tires\wheels. Ensure that vehicle transmission is in PARK & engage emergency brake. **Note:** Be sure steering wheel\wheels are pointing straight forward.
2. Remove OEM steering stabilizer from passenger side frame mount & from drag link\tie rod assembly stud mount.

1998-2001 Ram 1500. 1994-2002 Ram 2500 / 3500.
With Lift & Drop Pitman Arm: (# 2017, # 7017, # 8017, # 9017)

3. Install Skyjacker Steering Stabilizer. Install shaft eye of stabilizer to tie rod with supplied hardware. (Photo # HB-7017)

Place supplied 1/2" SAE Washer onto 1/2" x 3-1/2" Bolt. Insert Tapered Sleeve into tapered hole in OEM tie rod assembly stud mount. Insert bolt with washer through tapered sleeve \ tie rod hole. Place supplied 5/8" x 1-1/4" Spacer, shaft eye of stabilizer (with sleeve in eye), large 1/2" USS Washer & attach with 1/2" Nylon Insert Lock Nut. Secure, but **Do Not Completely Tighten** at this time using a 3/4" socket \ wrench. (Photo # 1 & # 2)

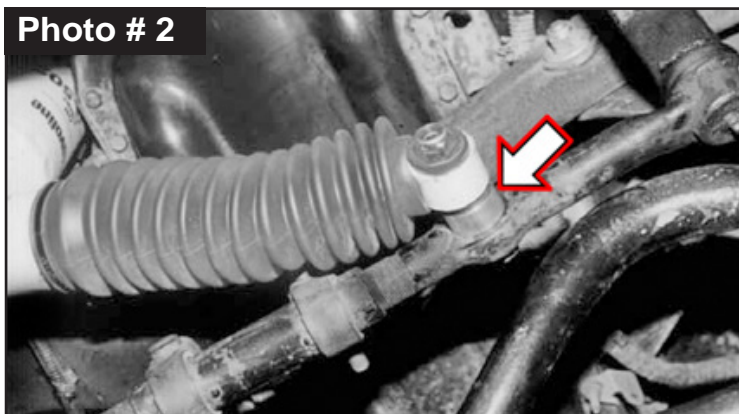
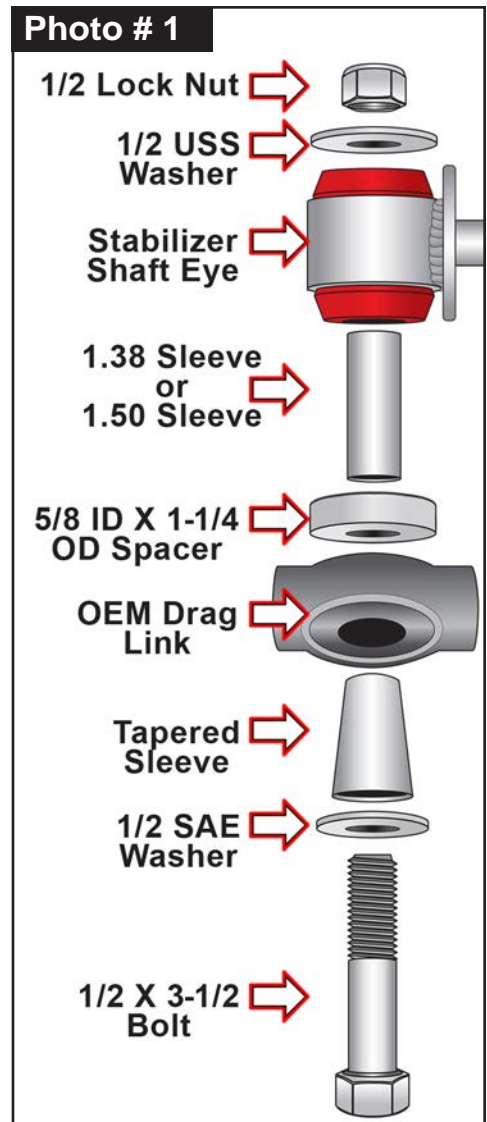

4. Install cylinder eye of stabilizer to frame mount with supplied hardware. (Photo # 3)
Note: DO NOT Install Inside OEM Mounting Tabs. OEM angle with a dropped pitman arm tends to put additional downward stress on tie rod.

Insert supplied 1/2" x 4" Bolt with 1/2" SAE Washer through cylinder eye of stabilizer & outer mounting tab. Place supplied 1.50" Steel Sleeve inside mounting tabs. Attach with supplied 1/2" Nylon Insert Lock Nut using a 3/4" socket \ wrench.

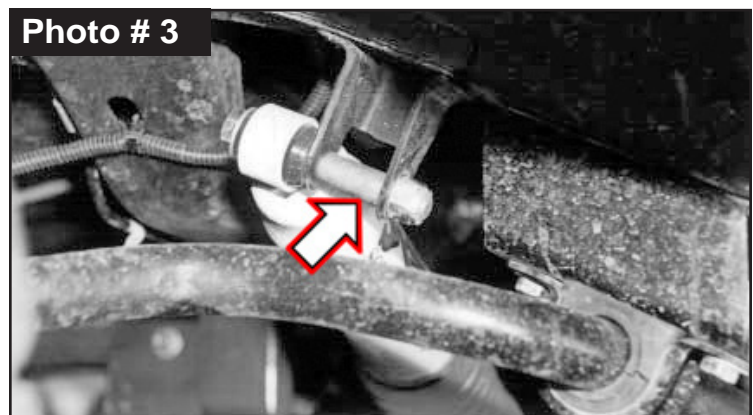

5. Tighten Both Mounts using a 3/4" socket \ wrench. Torque 65 ft-lb.
6. Cycle steering from side-to-side & check for adequate clearance. Check all brackets & bolts for proper installation.

1994-2001 Ram 1500. 1994-2002 Ram 2500/3500.
With OEM Pitman Arm: (# 2007, # 7007, # 8007, # 9007)

1994-1997 Ram 1500.
1994-1997 Ram 2500/3500.

1. Install Skyjacker Steering Stabilizer. Install shaft eye of stabilizer to tie rod with supplied hardware. (Photo # HB-7007)



Coat straight portion of # 81004 Stud & press into stabilizer shaft eye bushing. Install large flat washer, lock washer & nut. (Photo # 4) Tighten nut using 11/16" socket \ wrench until lock washer is compressed & bushing starts to swell slightly.



2. First attach Skyjacker Steering Stabilizer cylinder body to OEM frame mount with supplied 1/2" x 3-1/2" Bolt with 1/2" SAE Washer. Attach with supplied 1/2" Nylon Insert Lock Nut.

Next, extend stabilizer shaft end out & attach stabilizer stud to center of OEM tie rod assembly stud mount. (Photo # 5) Tighten stud into place with supplied lock nut using a 3/4" socket \ wrench. Torque 65 ft-lb.

Tighten at frame mount using 3/4" socket \ wrench. Torque 65 ft-lb.

3. Cycle steering from side-to-side & check for adequate clearance. Check all brackets & bolts for proper installation.

With OEM Pitman Arm: (# 2007, # 7007, # 8007, # 9007)

1998-2001 Ram 1500.
1994-1999 Ram 2500/3500.

1. Install Skyjacker Steering Stabilizer. Install shaft eye of stabilizer to tie rod with supplied hardware. (Photo # HB-7007) Coat straight portion of # 81004 Stud & press into stabilizer shaft eye bushing. Install large flat washer, lock washer & nut. (Photo # 4) Tighten nut using 11/16" socket \ wrench until lock washer is compressed & bushing starts to swell slightly.

2. First attach Skyjacker Steering Stabilizer cylinder body to OEM frame mount with OEM hardware. (Photo # 4) Next, extend stabilizer shaft end out & attach stabilizer stud to center of OEM tie rod assembly stud mount. (Photo # 5) Tighten stud into place with supplied lock nut using a 3/4" socket \ wrench. Torque 65 ft-lb.

Tighten at frame mount using 3/4" socket \ wrench. Torque 56 ft-lb.

3. Cycle steering from side-to-side & check for adequate clearance. Check all brackets & bolts for proper installation.

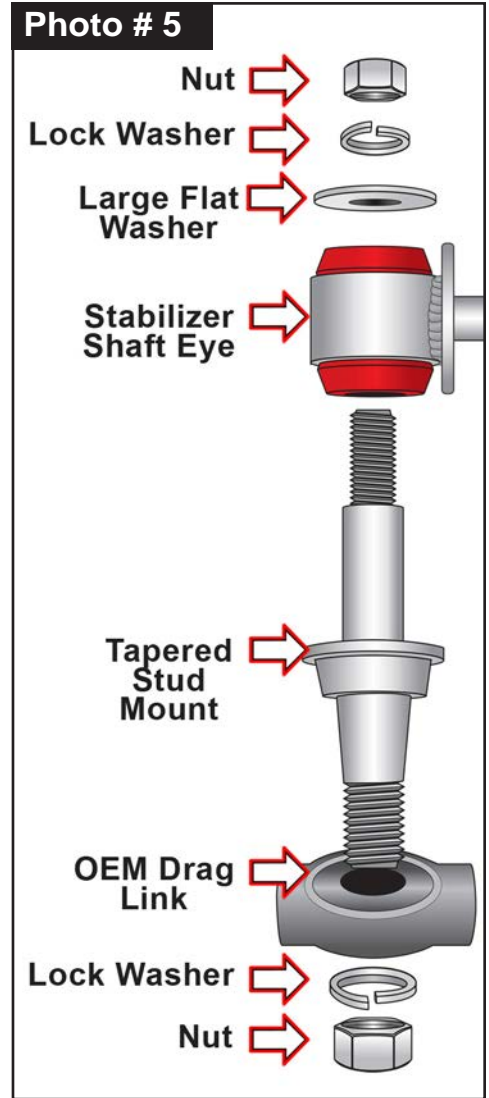

With OEM Pitman Arm: (# 2007, # 7007, # 8007, # 9007)

2000-2002 Ram 2500/3500.

1. Install Skyjacker Steering Stabilizer. Install shaft eye of stabilizer to tie rod with supplied hardware. (Photo # HB-7007)

Place supplied 1/2" SAE Washer onto 1/2" x 3-1/2" Bolt.

Insert Tapered Sleeve into tapered hole in OEM tie rod assembly stud mount.

Insert bolt with washer through tapered sleeve \ tie rod hole.

Place supplied 5/8" x 1-1/4" Spacer, shaft eye of stabilizer (with sleeve in eye), large 1/2" USS Washer & attach with 1/2" Nylon Insert Lock Nut.

Secure, but **Do Not Completely Tighten** at this time using a 3/4" socket \ wrench. (Photo # 6 & # 7)

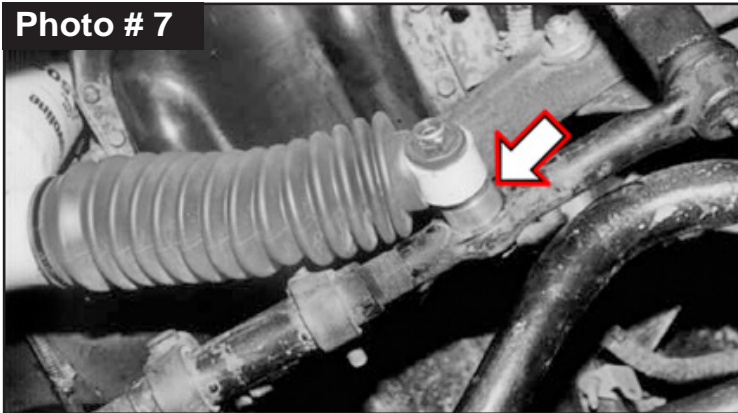
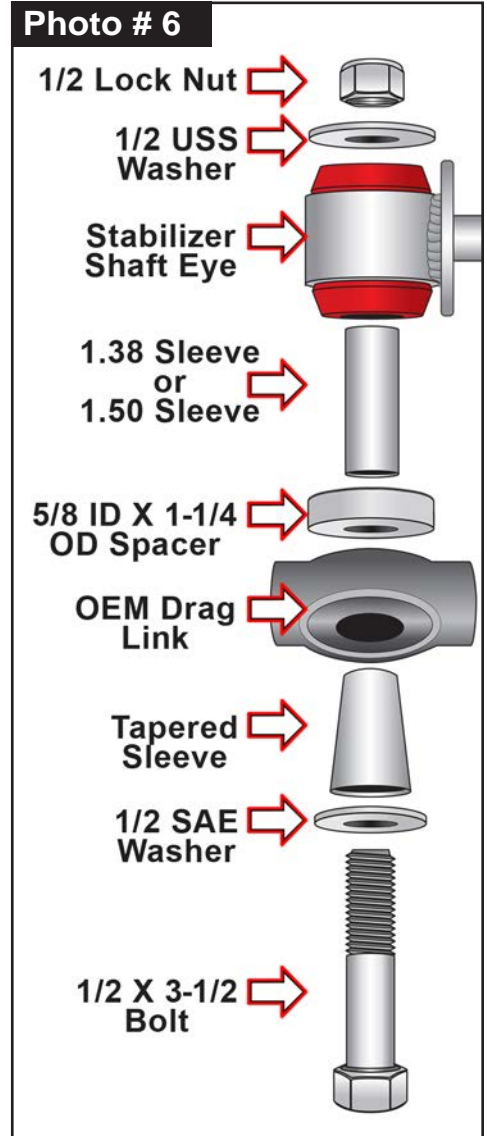

2. Install cylinder eye of stabilizer to frame mount with OEM hardware.
3. Tighten at frame mount. Torque 56 ft-lb. Tighten tie rod mount using a 3/4" socket \ wrench. Torque 65 ft-lb.
4. Cycle steering from side-to-side & check for adequate clearance. Check all brackets & bolts for proper installation.

Final Notes:

- After installation is complete, double check that all nuts & bolts are tight.
- With vehicle placed on ground, cycle steering lock to lock & inspect steering for proper operation, tightness & adequate clearance.
- After first 100 miles, check all hardware for proper torque & periodically thereafter.

TORQUE SPECIFICATIONS					
INCH SYSTEM			METRIC SYSTEM		
Bolt Size	Grade 5	Grade 8	Bolt Size	Class 8.8	Class 10.9
5/16	180 in-lbs	240 in-lbs	6MM	60 in-lbs	108 in-lbs
3/8	30 ft-lbs	35 ft-lbs	8MM	216 in-lbs	23 ft-lbs
7/16	45 ft-lbs	60 ft-lbs	10MM	32 ft-lbs	45 ft-lbs
1/2	65 ft-lbs	90 ft-lbs	12MM	55 ft-lbs	75 ft-lbs
9/16	95 ft-lbs	130 ft-lbs	14MM	85 ft-lbs	120 ft-lbs
5/8	135 ft-lbs	175 ft-lbs	16MM	130 ft-lbs	165 ft-lbs
3/4	185 ft-lbs	280 ft-lbs	18MM	170 ft-lbs	240 ft-lbs

**Above Specifications Are Not to Be Used
When Bolt Is Being Installed With a Bushing.**

Seat Belts Save Lives. Please Wear Your Seat Belt.

