

# SKYJACKER

## SUSPENSIONS

SKYJACKER.COM

2003-2010 Dodge Ram 2500 4WD  
 2003-2010 Dodge Ram 3500 4WD  
 2011-2013 RAM 2500 4WD  
 2011-2012 RAM 3500 4WD

### Required Tools List:

- SAE Sockets \ Wrenches (3/4")
- Metric Sockets \ Wrenches
- Diagonal Cutting Pliers
- Standard Flathead Screwdriver
- Ball Peen Hammer
- Safety Glasses
- Wheel Chock
- Torque Wrench

### HD OEM Replacement Steering Stabilizer Kit Installation Instructions



Before beginning the installation, read these instructions thoroughly & completely. Please refer to the Parts List to insure that all parts & hardware are received prior to disassembly of the vehicle. If any parts are found to be missing, contact SKYJACKER® Customer Service at 318-388-0816 to obtain the needed items. If you have any questions or reservations about installing this product, contact SKYJACKER® Technical Assistance at 318-388-0816.

### Component Box Breakdown:

#### Part # 2013

Item #	Description	Qty
2000AS	ADX HD STEERING DAMPER, ALU	1
ADXSD	DECAL, ADX 2.0 STABILIZER	1
HB-8013	HDWR BAG: 2013/8013 STAB.	1

#### Part # 7013

Item #	Description	Qty
7000WS	STEERING DAMPER, WHITE	1
B10RS	BOOT STABILIZER, RED	1
BTIE	BOOT CABLE TIE, RED	1
HYDRO 6X2-CL	DECAL, HYDRO STABILIZER	1
HB-7013	HDWR BAG: 7013/9013 STAB.	1

#### Part # 8013

Item #	Description	Qty
8000BS	STEERING DAMPER, BLACK	1
B10KS	BOOT STABILIZER, BLACK	1
BTIE-K	BOOT CABLE TIE, BLACK	1
MXSD	DECAL, BLACK MAX STABILIZER	1
HB-8013	HDWR BAG: 2013/8013 STAB.	1

#### Part # 9013

Item #	Description	Qty
9000WS	STEERING DAMPER, SILVER	1
B10KS	BOOT STABILIZER, BLACK	1
BTIE-K	BOOT CABLE TIE, BLACK	1
SSD	DECAL, SILVER STABILIZER	1
HB-7013	HDWR BAG: 7013/9013 STAB.	1

### Hardware Bag Breakdown:

#### Part # HB-7013

Item #	Description	Qty
HOURGLASS 5/8	HOURGLASS, 5/8 X 1.50, RED	2
141509	ES25 SLEEVE, 1.50 LONG	1
142121	ES24 SLEEVE, 1.38 LONG	1
12X412FTB	1/2 X 4-1/2 FINE THREAD BOLT	1
12FTN	1/2-20 FINE N/I LOCK NUT	1
12SAEW	1/2 SAE WASHER	1
12USSW	1/2 USS WASHER	1
81004	TAPERED SLEEVE, 1/2 ID	1
58SP	SPACER, 5/8 ID X 1-1/4 OD	1

#### Part # HB-8013

Item #	Description	Qty
HG5815-K	HOURGLASS, 5/8 X 1.50, BLACK	2
141509	ES25 SLEEVE, 1.50 LONG	1
142121	ES24 SLEEVE, 1.38 LONG	1
12X412FTB	1/2 X 4-1/2 FINE THREAD BOLT	1
12FTN	1/2-20 FINE N/I LOCK NUT	1
12SAEW	1/2 SAE WASHER	1
12USSW	1/2 USS WASHER	1
81004	TAPERED SLEEVE, 1/2 ID	1
58SP	SPACER, 5/8 ID X 1-1/4 OD	1

## **Pre-Installation Tips: Install Stabilizer Boot, Bushings & Sleeves.**

1. Install supplied Stabilizer Boot over Skyjacker Steering Stabilizer. Attach boot to cylinder body with supplied Boot Cable Tie. Remove excess cable tie with diagonal cutting pliers.
2. Coat Hourglass Bushings with a water resistant grease & press into Each Stabilizer Eye.  
Coat 1.38" Steel Sleeve with a water resistant grease & press into Cylinder Body Eye Bushing.  
Coat 1.50" Steel Sleeve with a water resistant grease & press into Shaft Rod Eye Bushing.

## **Installation: Note: Save all factory components & hardware for reuse, unless noted.**

1. Chock rear tires\wheels. Ensure that vehicle transmission is in PARK & engage emergency brake. **Note:** Be sure steering wheel\wheels are pointing straight forward.

2. Remove OEM steering stabilizer from passenger side OEM frame mount & from drag link\tie rod assembly stud mount. (Photo # 1)



3. Install Skyjacker #7013 Steering Stabilizer. Install shaft eye of stabilizer to tie rod with supplied hardware. (Photo # 2 Hardware & # 3 Overview)

Skyjacker # 81004 Tapered Sleeve is a pinch sleeve. Tap sleeve into tapered hole of OEM drag link assembly stud mount using a standard flathead screwdriver & hammer.

Place supplied large OD 1/2" USS Washer onto 1/2" x 4-1/2" Bolt.

Insert bolt with washer through shaft eye of stabilizer (with sleeve in eye).

Place supplied 5/8" ID x 1-1/4" OD Spacer between stabilizer & drag link. Continue bolt through drag link.

Attach with 1/2" SAE Washer & 1/2" Nylon Insert Lock Nut. Secure, but **Do Not Completely Tighten** at this time using a 3/4" socket \wrench.

4. Install cylinder eye of stabilizer into OEM passenger side OEM frame mount with OEM hardware.
5. Tighten at frame mount. Torque 56 ft-lb.  
Tighten at drag link mount. Torque 65 ft-lb.
6. Cycle steering from side-to-side & check for adequate clearance. Check all brackets & bolts for proper installation.

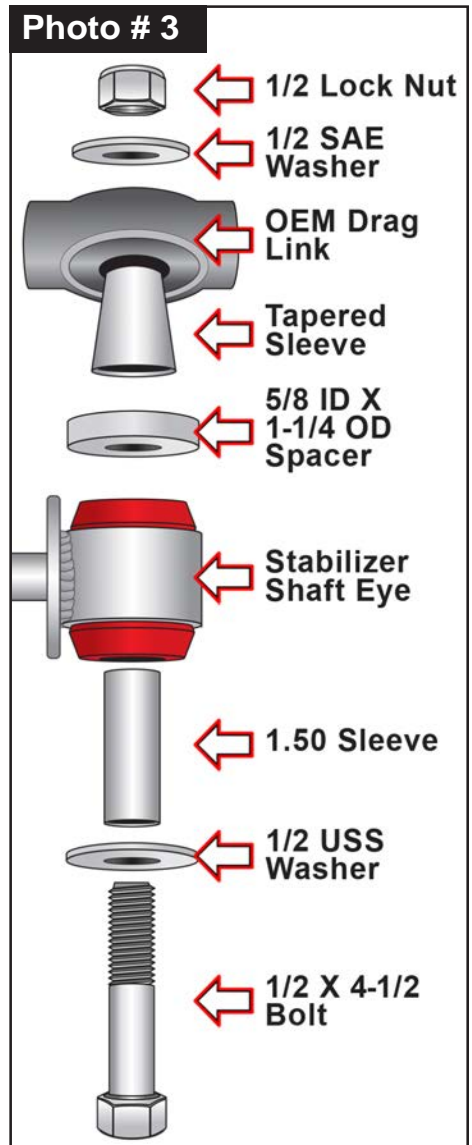

## **Final Notes:**

- After installation is complete, double check that all nuts & bolts are tight.
- With vehicle placed on ground, cycle steering lock to lock & inspect steering for proper operation, tightness & adequate clearance.
- After first 100 miles, check all hardware for proper torque & periodically thereafter.