

# SKYJACKER

## SUSPENSIONS

SKYJACKER.COM

2005-2010 Ford F250\F350 4WD  
 4" & 8.5" Lifts - # 2154, # 7154, # 8154 & # 9154  
 6" Lift - # 2156, # 7156, # 8156 & # 9156

### Single Steering Stabilizer Kit Installation Instructions

#### Required Tools List:

- SAE Sockets \ Wrenches (11/16" & 3/4")
- Metric Sockets \ Wrenches (18mm)
- Diagonal Cutting Pliers
- Needle Nose Pliers
- Ball Peen Hammer
- Safety Glasses
- Wheel Chock
- Torque Wrench



Before beginning the installation, read these instructions thoroughly & completely. Please refer to the Parts List to insure that all parts & hardware are received prior to disassembly of the vehicle. If any parts are found to be missing, contact SKYJACKER® Customer Service at 318-388-0816 to obtain the needed items. If you have any questions or reservations about installing this product, contact SKYJACKER® Technical Assistance at 318-388-0816.

#### Component Box Breakdown:

##### Part # 2154

Item #	Description	Qty
2000AS	ADX HD STEERING DAMPER, ALU	1
ADXSD	DECAL, ADX 2.0 STABILIZER	1
HB-8154T	HDWR BAG: 2154/8154 STAB.	1
7154-UB	STABILIZER UPPER BRACKET	1

##### Part # 7154

Item #	Description	Qty
7000WS	STEERING DAMPER, WHITE	1
B10RS	BOOT STABILIZER, RED	1
BTIE	BOOT CABLE TIE, RED	1
HYDRO 6X2-CL	DECAL, HYDRO STABILIZER	1
HB-7154T	HDWR BAG: 7154/9154 STAB.	1
7154-UB	STABILIZER UPPER BRACKET	1

##### Part # 8154

Item #	Description	Qty
8000BS	STEERING DAMPER, BLACK	1
B10KS	BOOT STABILIZER, BLACK	1
BTIE-K	BOOT CABLE TIE, BLACK	1
MXSD	DECAL, BLACK MAX STABILIZER	1
HB-8154T	HDWR BAG: 2154/8154 STAB.	1
7154-UB	STABILIZER UPPER BRACKET	1

##### Part # 9154

Item #	Description	Qty
9000WS	STEERING DAMPER, SILVER	1
B10KS	BOOT STABILIZER, BLACK	1
BTIE-K	BOOT CABLE TIE, BLACK	1
SSD	DECAL, SILVER STABILIZER	1
HB-7154T	HDWR BAG: 7154/9154 STAB.	1
7154-UB	STABILIZER UPPER BRACKET	1

#### Hardware Bag Breakdown:

##### Part # HB-7154T

Item #	Description	Qty
HOURGLASS 5/8	HOURGLASS, 5/8 X 1.50, RED	2
12X312FTB	1/2 X 3-1/2 FINE THREAD BOLT	1
12SAEW	1/2 SAE WASHER	2
12FTN	1/2 FINE THREAD N/I LOCK NUT	1
140629	EB6 STRAIGHT STUD, 141397	1
142121	ES24 SLEEVE, 1.38 LONG	1
SSB5468-T	TAPERED SLEEVE, 3/4 LONG	1
81004	TAPERED SLEEVE, 5/8 LONG	1
58SP	SPACER, 5/8 X 1-1/4 O.D.	1

##### Part # HB-8154T

Item #	Description	Qty
HG5815-K	HOURGLASS, 5/8 X 1.50, BLACK	2
12X312FTB	1/2 X 3-1/2 FINE THREAD BOLT	1
12SAEW	1/2 SAE WASHER	2
12FTN	1/2 FINE THREAD N/I LOCK NUT	1
140629	EB6 STRAIGHT STUD, 141397	1
142121	ES24 SLEEVE, 1.38 LONG	1
SSB5468-T	TAPERED SLEEVE, 3/4 LONG	1
81004	TAPERED SLEEVE, 5/8 LONG	1
58SP	SPACER, 5/8 X 1-1/4 O.D.	1



## Component Box Breakdown:

### Part # 2156

Item #	Description	Qty
2000AS	ADX HD STEERING DAMPER, ALU	1
ADXSD	DECAL, ADX 2.0 STABILIZER	1
HB-8156T	HDWR BAG: 2156/8156 STAB.	1
7156-UB	STABILIZER UPPER BRACKET	1

### Part # 7156

Item #	Description	Qty
7000WS	STEERING DAMPER, WHITE	1
B10RS	BOOT STABILIZER, RED	1
BTIE	BOOT CABLE TIE, RED	1
HYDRO 6X2-CL	DECAL, HYDRO STABILIZER	1
HB-7156T	HDWR BAG: 7156/9156 STAB.	1
7156-UB	STABILIZER UPPER BRACKET	1

### Part # 8156

Item #	Description	Qty
8000BS	STEERING DAMPER, BLACK	1
B10KS	BOOT STABILIZER, BLACK	1
BTIE-K	BOOT CABLE TIE, BLACK	1
MXSD	DECAL, BLACK MAX STABILIZER	1
HB-8156T	HDWR BAG: 2156/8156 STAB.	1
7156-UB	STABILIZER UPPER BRACKET	1

### Part # 9156

Item #	Description	Qty
9000WS	STEERING DAMPER, SILVER	1
B10KS	BOOT STABILIZER, BLACK	1
BTIE-K	BOOT CABLE TIE, BLACK	1
SSD	DECAL, SILVER STABILIZER	1
HB-7156T	HDWR BAG: 7156/9156 STAB.	1
7156-UB	STABILIZER UPPER BRACKET	1

## Hardware Bag Breakdown:

### Part # HB-7156T

Item #	Description	Qty
HOURGLASS 5/8	HOURGLASS, 5/8 X 1.50, RED	2
12X114FTB	1/2 X 1-1/4 FINE THREAD BOLT	1
12SAEW	1/2 SAE WASHER	2
12FTN	1/2 FINE THREAD N/I LOCK NUT	1
140629	EB6 STRAIGHT STUD, 141397	1
P837	TAPERED STUD MOUNT, 141264	1
SSB5468-T	TAPERED SLEEVE, 3/4 LONG	1

### Part # HB-8156T

Item #	Description	Qty
HG5815-K	HOURGLASS, 5/8 X 1.50, BLACK	2
12X114FTB	1/2 X 1-1/4 FINE THREAD BOLT	1
12SAEW	1/2 SAE WASHER	2
12FTN	1/2 FINE THREAD N/I LOCK NUT	1
140629	EB6 STRAIGHT STUD, 141397	1
P837	TAPERED STUD MOUNT, 141264	1
SSB5468-T	TAPERED SLEEVE, 3/4 LONG	1



## # 2154, # 7154, # 8154 & # 9154: 4" & 8.5" Lift Kit

### Pre-Installation Tips: Install Stabilizer Boot, Bushings & Hardware.

1. Install supplied Stabilizer Boot over Skyjacker Steering Stabilizer. Attach boot to cylinder body with supplied Boot Cable Tie. Remove excess cable tie with diagonal cutting pliers.
2. **# 2154, # 7154, # 8154 & # 9154** Coat Hourglass Bushings with a water resistant grease & press into Each Stabilizer Eye.

Coat 1.38" Steel Sleeve & press into Shaft Rod Eye Bushing Only.  
(Photo # 1)

Coat straight portion of # EB6 Straight Stud & press into Cylinder Body Eye Bushing. Install large flat washer, lock washer & nut.  
(Photo # 2) Tighten nut

using 11/16" socket\wrench until lock washer is compressed & bushing starts to swell slightly.

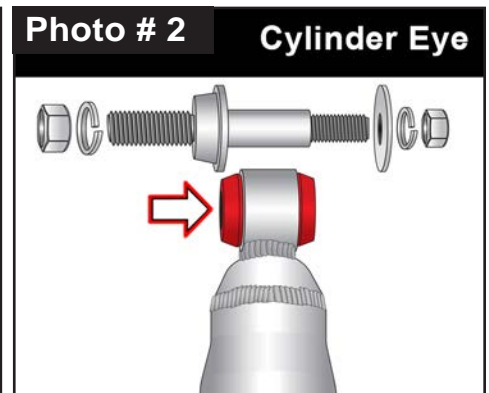
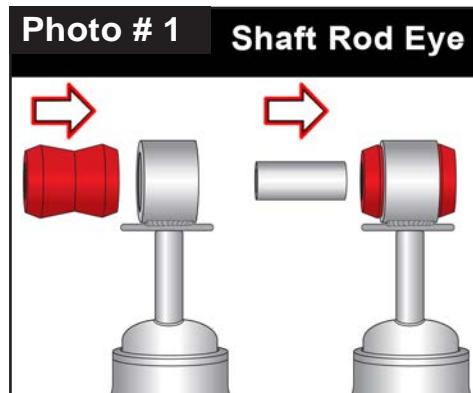

**Installation: Note: Save all factory components & hardware for reuse, unless noted.**

1. Chock rear tires\wheels. Ensure that vehicle transmission is in PARK & engage emergency brake. **Note:** Be sure steering wheel\wheels are pointing straight forward.
2. Disconnect OEM steering stabilizer from OEM drag link\tie rod assembly stud mount. Remove stud cotter pin using needle nose pliers. Remove castle nut using a 18mm socket\wrench. Remove OEM steering stabilizer. **Note:** Stud is a tapered press fit & may be difficult to remove. Apply penetrating oil. Tap stud using a ball peen hammer to loosen.
3. Remove OEM steering stabilizer & OEM bracket from crossmember using a 18mm socket\wrench. (Photo # 3) Retain OEM bolt plate & nuts for reuse.
4. Install Skyjacker # 7154-UB Stabilizer Upper Bracket inside of OEM crossmember. (Photo # 4) Attach with OEM bolt plate from front-to-rear through OEM crossmember & Skyjacker bracket with OEM nuts using a 18mm socket\wrench. Torque to 75 ft-lbs.
5. Install Skyjacker stabilizer cylinder eye with EB6 Straight Stud to Skyjacker bracket. **NOTE:** 4" Lift - Stud Will Mount to Top of Bracket. (Photo # 5)  
8.5" Lift - Stud Will Mount to Bottom of Bracket. (Photo # 5)  
Tighten stud into place with supplied lock nut using a 3/4" socket\wrench. Torque 65 ft-lb.

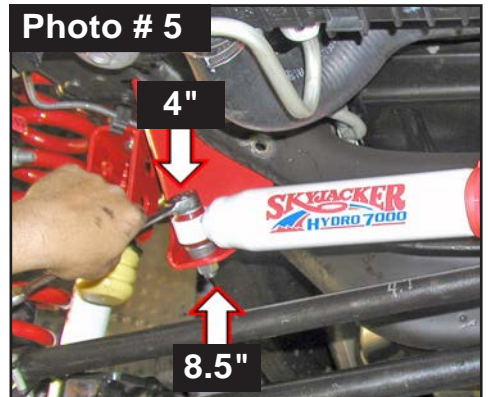
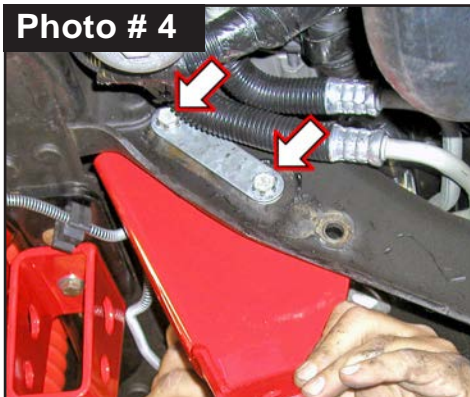
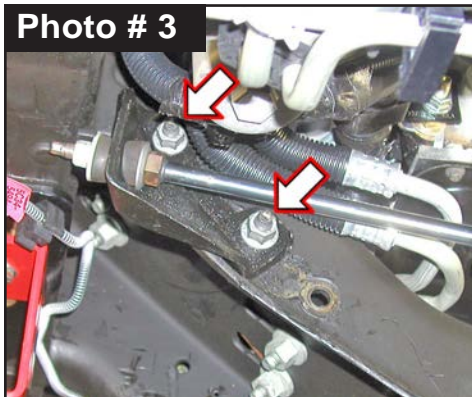

6. Install shaft eye of stabilizer into OEM drag link\tie rod assembly stud mount with supplied hardware. (Photo # 6 & # 12)  
Insert 3/4" Long Tapered Sleeve into tapered hole of OEM drag link stud mount.  
Insert 5/8" Long Tapered Sleeve into Skyjacker tapered sleeve in OEM drag link stud mount.  
Place supplied 1/2" SAE Washer onto 1/2" x 3-1/2" Bolt. Insert bolt with washer through shaft eye of stabilizer.  
Place supplied 5/8" x 1-1/4" Spacer on top of OEM drag link.  
Attach with supplied 1/2" SAE Washer & 1/2" Nylon Insert Lock Nut using a 3/4" socket\wrench. Torque 65 ft-lb.

**Final Notes:**

- After installation is complete, double check that all nuts & bolts are tight.
- With vehicle placed on ground, cycle steering lock to lock & inspect steering for proper operation, tightness & adequate clearance.
- After first 100 miles, check all hardware for proper torque & periodically thereafter.

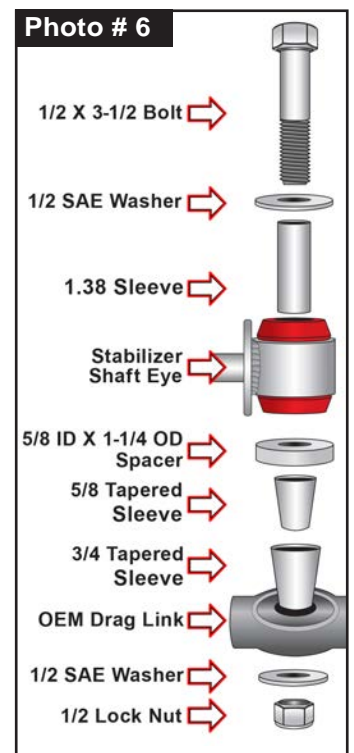

## # 2156, # 7156, # 8156 & # 9156: 6" Lift Kit

### Pre-Installation Tips: Install Stabilizer Boot, Bushings & Hardware.

1. Install supplied Stabilizer Boot over Skyjacker Steering Stabilizer. Attach boot to cylinder body with supplied Boot Cable Tie. Remove excess cable tie with diagonal cutting pliers.
2. **# 2156, # 7156, # 8156 & # 9156** Coat Hourglass Bushings with a water resistant grease & press into Each Stabilizer Eye.

Coat straight portion of # EB6 Straight Stud & press into Cylinder Body Eye Bushing. Install large flat washer, lock washer & nut. (Photo # 7) Tighten nut using 11/16" socket \ wrench until lock washer is compressed & bushing starts to swell slightly.

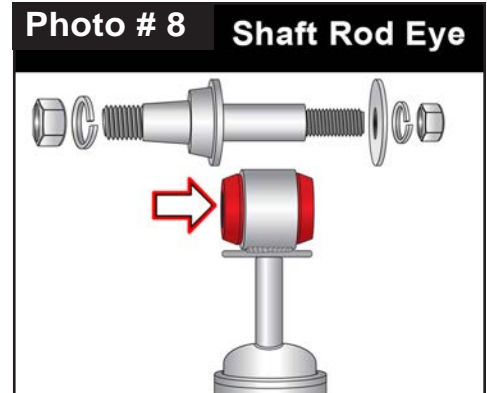
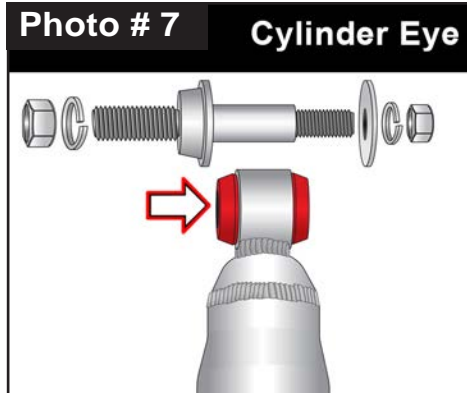

Coat straight portion of # P837 Tapered Stud & press into Shaft Rod Eye Bushing. (Photo # 8) Install large flat washer, lock washer & nut. Tighten nut using 11/16" socket \ wrench until lock washer is compressed & bushing starts to swell slightly.

### Installation: Note: Save all factory components & hardware for reuse, unless noted.

1. Chock rear tires \ wheels. Ensure that vehicle transmission is in PARK and engage emergency brake. **Note:** Be sure steering wheel \ wheels are pointing straight forward.
2. Disconnect OEM steering stabilizer from OEM drag link \ tie rod assembly stud mount. Remove stud cotter pin using needle nose pliers. Remove castle nut using a 18mm socket \ wrench. Remove OEM steering stabilizer. **Note:** Stud is a tapered press fit & may be difficult to remove. Apply penetrating oil. Tap stud using a ball peen hammer to loosen.
3. Remove OEM steering stabilizer & OEM bracket from crossmember using a 18mm socket \ wrench. (Photo # 9)

Retain OEM bolt plate & nuts for reuse.

4. Install Skyjacker # # 7156-UB Stabilizer Upper Bracket inside of OEM crossmember. (Photo # 10)

Attach with OEM bolt plate from front-to-rear through OEM crossmember &

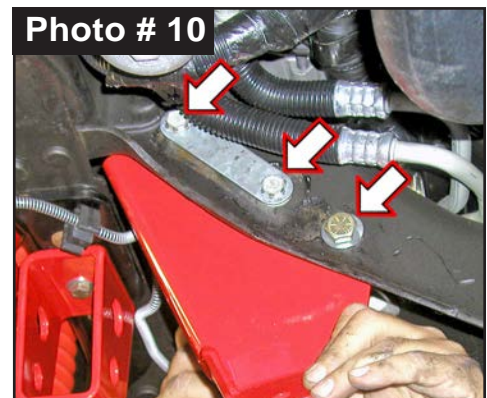
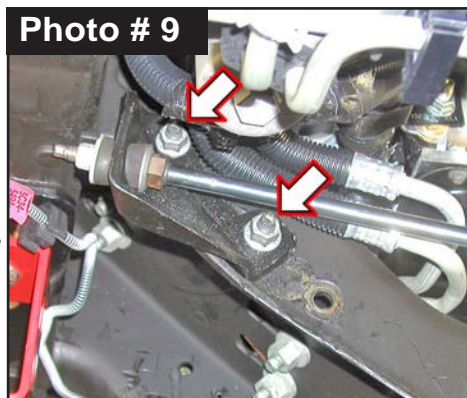

Skyjacker bracket with OEM nuts using a 18mm socket \ wrench.

Install supplied 1/2" x 1-1/4" Bolt with 1/2" SAE Washer from front-to-rear through OEM hole in crossmember & Skyjacker bracket. Attach with supplied 1/2" SAE Washer & 1/2" Nylon Insert Lock Nut using a 3/4" socket \ wrench.

Torque OEM nuts to 75 ft-lbs. Torque 1/2" to 90 ft-lbs.

5. Install Skyjacker stabilizer cylinder eye with EB6 Straight Stud to Skyjacker bracket. (Photo # 11)

Tighten with supplied lock nut using a 3/4" socket \ wrench. Torque 65 ft-lb.

6. Next, extend stabilizer shaft end out to OEM drag link stud mount. (Photo # 11)

Insert 3/4" Long Tapered Sleeve into tapered hole of OEM drag link stud mount.

Tighten stud into place with supplied lock nut using a 3/4" socket \ wrench. Torque 65 ft-lb.

7. Cycle steering from side-to-side & check for adequate clearance. Check all brackets & bolts for proper installation.



### **Final Notes:**

- After installation is complete, double check that all nuts & bolts are tight.
- With vehicle placed on ground, cycle steering lock to lock & inspect steering for proper operation, tightness & adequate clearance.
- After first 100 miles, check all hardware for proper torque & periodically thereafter.

<b>TORQUE SPECIFICATIONS</b>					
<b>INCH SYSTEM</b>			<b>METRIC SYSTEM</b>		
<b>Bolt Size</b>	<b>Grade 5</b>	<b>Grade 8</b>	<b>Bolt Size</b>	<b>Class 8.8</b>	<b>Class 10.9</b>
5/16	180 in-lbs	240 in-lbs	6MM	60 in-lbs	108 in-lbs
3/8	30 ft-lbs	35 ft-lbs	8MM	216 in-lbs	23 ft-lbs
7/16	45 ft-lbs	60 ft-lbs	10MM	32 ft-lbs	45 ft-lbs
1/2	65 ft-lbs	90 ft-lbs	12MM	55 ft-lbs	75 ft-lbs
9/16	95 ft-lbs	130 ft-lbs	14MM	85 ft-lbs	120 ft-lbs
5/8	135 ft-lbs	175 ft-lbs	16MM	130 ft-lbs	165 ft-lbs
3/4	185 ft-lbs	280 ft-lbs	18MM	170 ft-lbs	240 ft-lbs
<b>Above Specifications Are Not to Be Used When Bolt Is Being Installed With a Bushing.</b>					

**Seat Belts Save Lives. Please Wear Your Seat Belt.**

# SKYJACKER

## SUSPENSIONS

SKYJACKER.COM

Check Out Our Favorite Ministries at:

- [innministries.org](http://innministries.org)
- [familychurch.org](http://familychurch.org)
- [kcm.org](http://kcm.org)

## Jesus Christ Died For You.

John 3:16

For God so loved the world that He gave His only Son, so that everyone who believes in Him should not perish, but have everlasting life.

Romans 3:23

For all have sinned; all fall short of God's glorious standard.

Ephesians 2:8

God saved you by his special favor when you believed. And you can't take credit for this; it is a gift from God.

Psalms 18:2

The Lord is my Rock, my fortress, and my savior; my God is my Rock, in whom I find protection. He is my shield, the strength of my salvation, and my stronghold.

Romans 10:9-10

That if you shall confess with thy mouth the Lord Jesus, and shall believe in your heart that God hath raised him from the dead, you shall be saved. For with the heart man believeth unto righteousness; and with the mouth confession is made unto salvation.

Pray This Simple Prayer:

God, I come to You admitting I have sinned against You and I need you to take control of my life. The Bible says anyone who calls on the name of the Lord will be saved.

I am calling on You, Jesus. I ask that You come live in my heart and be the Lord over my life today. I do believe You died on the cross for me and came back to life to give me life! Thank You, Lord Jesus for a new life in You! Amen.

Now, go and tell somebody about your new life in Jesus, get a Bible, begin to read it, and go to a Bible believing church.

If you would like someone to pray with you, call Kenneth Copeland Ministries anytime at 800-600-7395.

To listen to commercial free Christian radio on the web, go to [www.887fm.org](http://www.887fm.org)



**JESUS  
FORGIVES  
ROCKS  
DON'T**

## Jesús murió por ti.

Juan 3:16

Porque tanto amó Dios al mundo, que dio a su Hijo unigénito, para que todo el que cree en él no se pierda, sino que tenga vida eterna.

Romanos 3:23

Pues todos han pecado y están privados de la gloria de Dios.

Efesios 2:8

Porque por gracia ustedes han sido salvados mediante la fe; esto no procede de ustedes, sino que es el regalo de Dios.

Salmos 18:2

El Señor es mi roca, mi amparo, mi libertador; es mi Dios, el peñasco en que me refugio. Es mi escudo, el poder que me salva, ¡mi más alto escondite!

Romanos 10:9-10

Que si confiesas con tu boca que Jesús es el Señor, y crees en tu corazón que Dios lo levantó de entre los muertos, serás salvo. Porque con el corazón se cree para ser justificado, pero con la boca se confiesa para ser salvo.

Ahora dí esta simple oración:

Dios, vengo a Ti y admito que he pecado contra Ti, necesito que tomes el control de mi vida. La Biblia dice que todo aquel que invoca el nombre del Señor escapará con vida. En este momento yo clamo ante Ti, Jesús; te pido que vengas a vivir en mi corazón y que tomes el control de mi vida. ¡Yo creo que tu moriste en la cruz y resucitaste para darme vida! ¡Gracias Señor Jesús, por una nueva vida que tengo en Ti! Amén.

Ahora ve y dile a alguien sobre la nueva vida que tienes en Cristo. Compra una Biblia y empieza a leerla. Busca una Iglesia que cree en la Biblia y hazte parte de esa Iglesia.

Si te gustaría orar con alguien, puedes llamar a este número 800-600-7395

Puedes ir a este sitio de Internet para escuchar música Cristiana sin anuncios, [www.887fm.org](http://www.887fm.org)

