

SKYJACKER

SUSPENSIONS

SKYJACKER.COM

2014-2023 RAM 2500 4WD 2013-2023 RAM 3500 4WD (Vehicles with Minimum of 4" Lift) Dual Steering Stabilizer Kit Installation Instructions

Required Tools List:

- SAE Sockets \ Wrenches (1/2", 9/16", & 11/16")
- Metric Sockets \ Wrenches (13mm, 17mm & 18mm)
- Diagonal Cutting Pliers
- Adjustable Pliers
- Safety Glasses
- Wheel Chock
- Torque Wrench

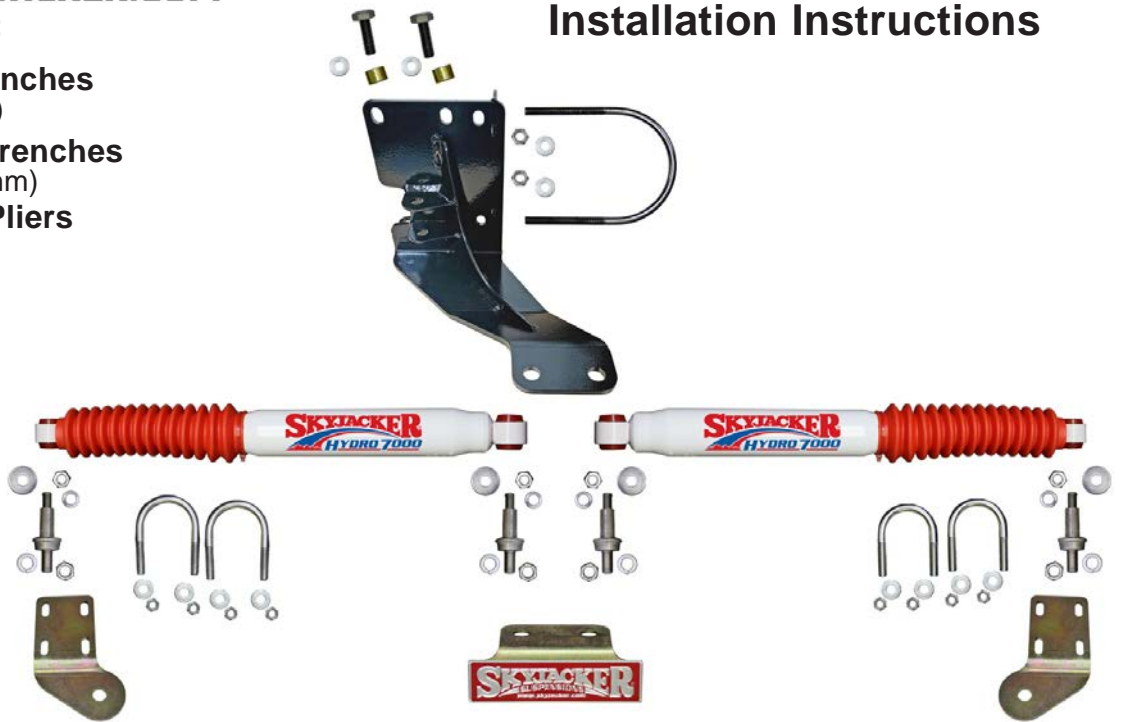

Before beginning the installation, read these instructions thoroughly & completely. Please refer to the Parts List to insure that all parts & hardware are received prior to disassembly of the vehicle. If any parts are found to be missing, contact SKYJACKER® Customer Service at 318-388-0816 to obtain the needed items. If you have any questions or reservations about installing this product, contact SKYJACKER® Technical Assistance at 318-388-0816.

Important Notes:

- This Steering Stabilizer Kit Requires A Minimum of 4" Lift.

Component Box Breakdown:

Part # 2214		
Item #	Description	Qty
2000AS	ADX HD STEERING DAMPER, ALU	2
ADXSD	DECAL, ADX 2.0 STABILIZER	2
HB-8214	HDWR BAG: 2214 / 8214 STAB.	1
7214-MB	BRACKET, CENTER MAIN	1
Part # 8214		
Item #	Description	Qty
8000BS	STEERING DAMPER, BLACK	2
B10KS	BOOT STABILIZER, BLACK	2
BTIE-K	BOOT CABLE TIE, BLACK	2
MXSD	DECAL, BLACK MAX STABILIZER	2
HB-8214	HDWR BAG: 2214 / 8214 STAB.	1
7214-MB	BRACKET, CENTER MAIN	1

Hardware Bag Breakdown:

Part # HB-8214		
Item #	Description	Qty
10MMX30MMB	10MM X 30MM BOLT / 10.9	2
140629	EB6 STUD, BAG # 141397	4
38X4X558U	3/8 X 4 X 5-5/8 U-BOLT, RD	1
38FTN	3/8 FINE THREAD N/I LOCK NUT	2
38SAEW	3/8 SAE WASHER	4
516X112X214U	5/16 X 1-1/2 X 2-1/4 U-BOLT, RD	2
516X134X258U	5/16 X 1-3/4 X 2-5/8 U-BOLT, RD	2
516SAEW	5/16 SAE WASHER	8
516CTN	5/16 COURSE N/I LOCK NUT	8
CS0438	CRUSH SLEEVE, .438 LONG	2
HG5815-K	HOURGLASS, 5/8 X 1.50, BLACK	4
7214-6	BRACKET, FRONT NAME PLATE	1
7218-DB	TIE ROD BRACKET, PASSENGER	1
7254-PB	TIE ROD BRACKET, DRIVER	1

Component Box Breakdown:**Part # 7214**

Item #	Description	Qty
7000WS	STEERING DAMPER, WHITE	2
B10RS	BOOT STABILIZER, RED	2
BTIE	BOOT CABLE TIE, RED	2
HYDRO 6X2-CL	DECAL, HYDRO STABILIZER	2
HB-7214	HDWR BAG: 7214/9214 STAB.	1
7214-MB	BRACKET, CENTER MAIN	1

Part # 9214

Item #	Description	Qty
9000WS	STEERING DAMPER, SILVER	2
B10KS	BOOT STABILIZER, BLACK	2
BTIE-K	BOOT CABLE TIE, BLACK	2
SSD	DECAL, SILVER STABILIZER	2
HB-7214	HDWR BAG: 7214/9214 STAB.	1
7214-MB	BRACKET, CENTER MAIN	1

Hardware Bag Breakdown:**Part # HB-7214**

Item #	Description	Qty
10MMX30MMB	10MM X 30MM BOLT / 10.9	2
140629	EB6 STUD, BAG # 141397	4
38X4X558U	3/8 X 4 X 5-5/8 U-BOLT, RD	1
38FTN	3/8 FINE THREAD N/I LOCK NUT	2
38SAEW	3/8 SAE WASHER	4
516X112X214U	5/16 X 1-1/2 X 2-1/4 U-BOLT, RD	2
516X134X258U	5/16 X 1-3/4 X 2-5/8 U-BOLT, RD	2
516SAEW	5/16 SAE WASHER	8
516CTN	5/16 COURSE N/I LOCK NUT	8
CS0438	CRUSH SLEEVE, .438 LONG	2
HOURGLASS 5/8	HOURGLASS, 5/8 X 1.50, RED	4
7214-6	BRACKET, FRONT NAME PLATE	1
7218-DB	TIE ROD BRACKET, PASSENGER	1
7254-PB	TIE ROD BRACKET, DRIVER	1

Pre-Installation Tips: Install Stabilizer Boots & Bushings.

1. Install supplied Stabilizer Boot over Skyjacker Steering Stabilizer. Attach boot to cylinder body with supplied Boot Cable Tie. Remove excess cable tie with diagonal cutting pliers.
2. Coat Hourglass Bushings with a water resistant grease & press into Each Stabilizer Eye.

Installation: Note: Save all factory components & hardware for reuse, unless noted.

1. Chock rear tires\wheels. Ensure that vehicle transmission is in PARK & engage emergency brake. **Note:** Be sure steering wheel\wheels are pointing straight forward.
2. Remove OEM steering stabilizer from passenger side mount & axle center bracket mount using a 18mm socket\wrench. (Photo # 1)
3. Remove OEM stabilizer axle center bracket using a 13mm socket\wrench. (Photo # 2)
4. Loosen driver side OEM tie rod clamp using an 18mm socket\wrench. Rotate driver side OEM tie rod clamp 180 degrees. Install OEM hardware front-to-back with OEM nut toward rear of vehicle. Tighten using an 18mm socket\wrench. (Photo # 3)

Tech Note: Some year splits have a double tie rod clamp on the driver side.

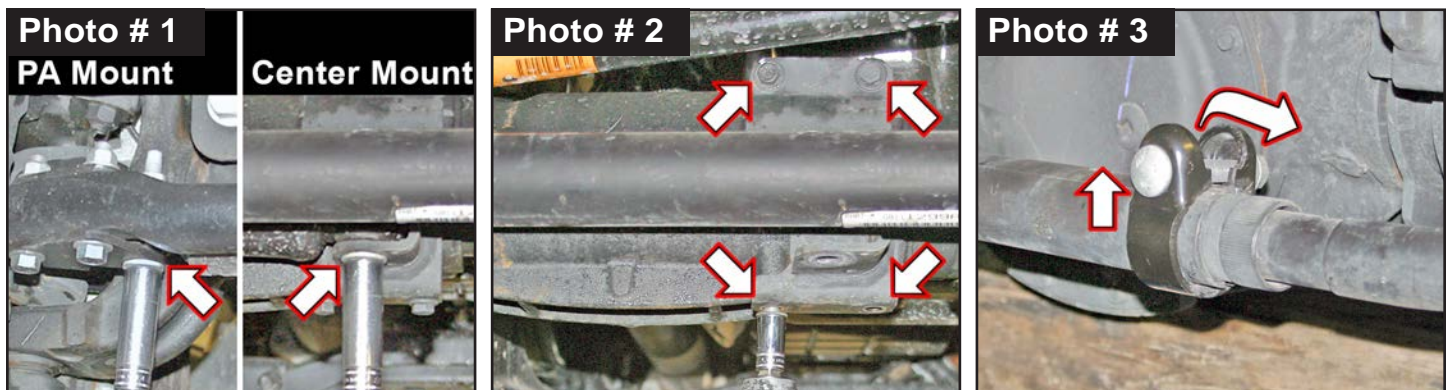

- Attach Skyjacker # 7214-MB Center Bracket into upper OEM axle center mount with supplied Crush Sleeves, 10mm x 30mm Bolts, 3/8" SAE Washers using a 17mm socket \wrench.
NOTE: Crush Sleeves are installed between OEM axle center mount & Skyjacker Center Bracket. (Photo # 4) Secure, but **Do Not Completely Tighten**.
- Attach Skyjacker # 7214-MB Center Bracket into lower OEM axle center mount with OEM hardware using a 13mm socket \wrench. (Photo # 5)
- Install supplied 3/8" x 4" x 5-5/8" U-bolt from rear-to-front around OEM axle tube through Center Bracket. Attach with supplied 3/8" SAE Washers & 3/8" Nylon Insert Lock Nuts using a 9/16" socket \wrench. (Photo # 6)

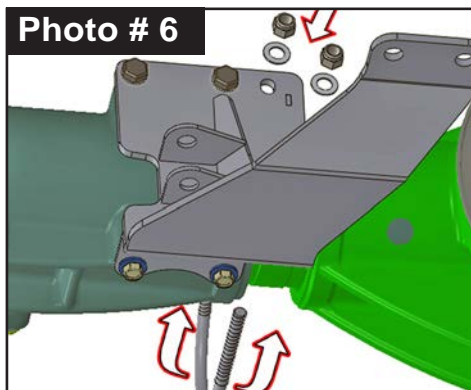
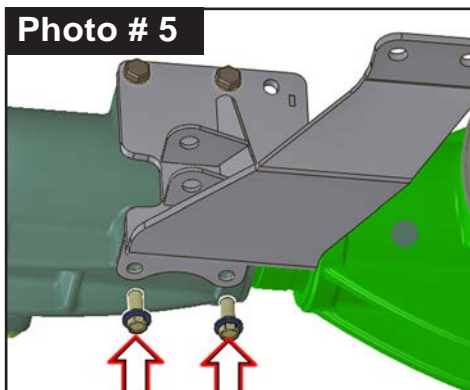
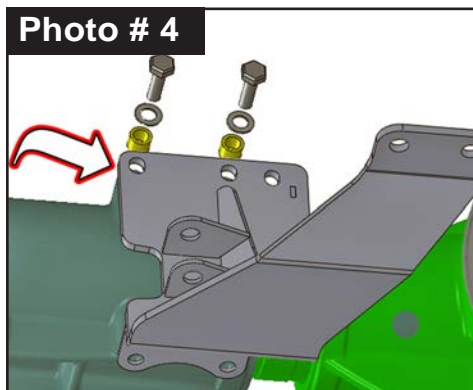

- Tighten 10mm Bolts at upper mount. Torque 45 ft-lbs.
Tighten OEM Bolts at lower mount. Torque 45 ft-lbs.
Tighten U-Bolt. Torque 30 ft-lbs.

- Install OEM steering stabilizer into Skyjacker Center Bracket with OEM hardware using an 18mm socket \wrench.
Note: Install OEM bolt from top-to-bottom with OEM nut to bottom. (Photo # 7) Torque OEM Bolts 45 ft-lbs.

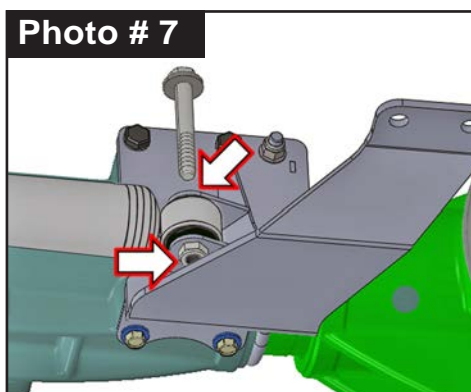

Attach OEM steering stabilizer to passenger side mount with OEM hardware using a 18mm socket \wrench. Torque OEM Bolts 45 ft-lbs

- Attach two (2) supplied Skyjacker # EB6 Straight Studs to Skyjacker Center Bracket tab hole mounts with supplied Lock Washer & Nut using adjustable pliers & a 11/16" socket \wrench. (Photo # 8)

- Locate Skyjacker Tie Rod Brackets.
Note: Skyjacker Tie Rod Brackets Are Side Specific: Driver # 7254-PB & Passenger # 7218-DB.
Tech Note: Tie Rod Brackets are to be installed with the offset \ bend portion of bracket pointing downward with stabilizer mounting tab toward the inside of the vehicle. (Photo # 9)

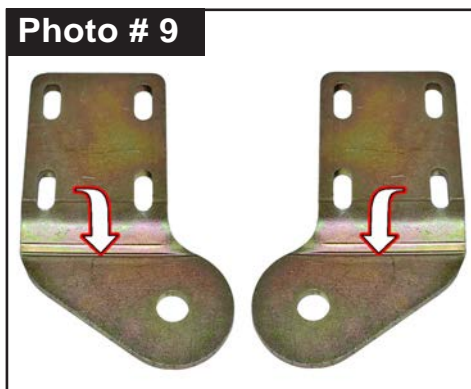

12. On Passenger Side, place Skyjacker # 7218-DB Tie Rod Bracket against bottom of tie rod. Install supplied 5/16" x 1-3/4" x 2-5/8" U-Bolts from top-to-bottom around OEM tie rod through Skyjacker bracket mounting holes. (Photo # 10)
Attach U-Bolts with supplied 5/16" SAE Washers & 5/16" Nylon Insert Lock Nut using a 1/2" socket \ wrench. Secure, but **Do Not Completely Tighten**.
13. Attach supplied Skyjacker EB6 Straight Stud to Tie Rod Bracket tab hole mount with supplied Lock Washer & Nut using adjustable pliers & a 11/16" socket \ wrench. (Photo # 11)
14. On Driver Side, repeat process with Skyjacker # 7254-PB Tie Rod Bracket with supplied 5/16" x 1-1/2" x 2-1/4" U-Bolts & # EB6 Straight Stud. (Photo # 12)

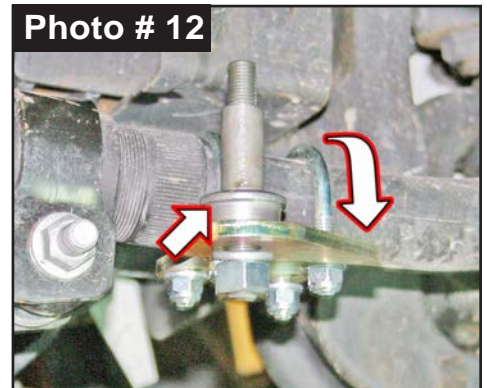
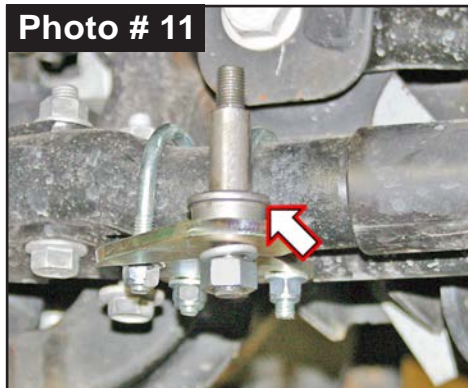
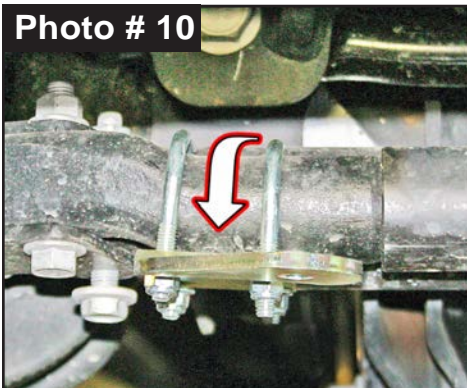

15. Coat straight portion of each # EB6 Straight Stud mount on Center Axle Bracket with a water resistant grease. Press stabilizer cylinder body eye bushing onto stud. (Photo # 13)

Attach Skyjacker # 7214-6 Name Plate Bracket onto studs at Center Axle Bracket. Attach with supplied Large Flat Washer then Lock Washer & Nut. Tighten nut using 11/16" socket \ wrench until lock washer is compressed & bushing starts to swell slightly.



16. On Passenger Side Tie Rod Bracket, coat straight portion of # EB6 Straight Stud mount with a water resistant grease.

Extend stabilizer shaft out & press stabilizer shaft eye bushing onto stud. Attach with supplied Large Flat Washer then Lock Washer & Nut. Tighten nut using 11/16" socket \ wrench until lock washer is compressed & bushing starts to swell slightly. (Photo # 14)

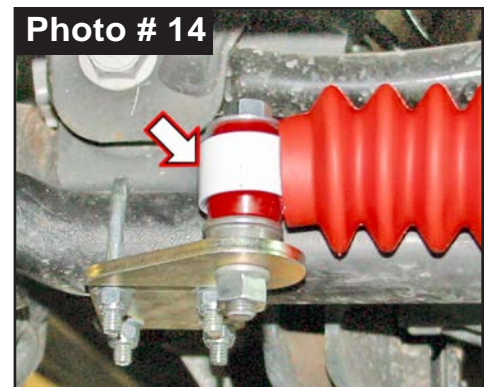

17. Repeat Step 16 on Driver Side.

18. Extend each Skyjacker Tie Rod Bracket \ Shaft End out exactly half way.
4-1/4 Inches.
 Measure from end of cylinder body to shaft stem washer. (Photo # 15)

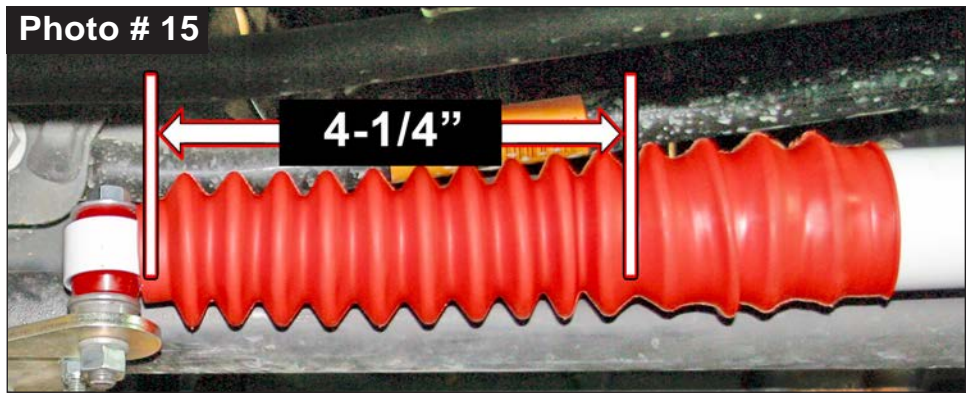

19. Cycle steering from side-to-side & check for adequate clearance.

Check all brackets & bolts for proper installation.

Tech Note: For proper clearance during suspension travel, be sure OEM tie rod adjustment clamps \ collars are rolled Upward. (Photo # 3)

20. Torque Tie Rod Bracket U-Bolts 30 ft-lbs.

Final Notes:

- After installation is complete, double check that all nuts & bolts are tight.
- With vehicle placed on ground, cycle steering lock to lock & inspect steering for proper operation, tightness & adequate clearance.
- After first 100 miles, check all hardware for proper torque & periodically thereafter.

TORQUE SPECIFICATIONS					
INCH SYSTEM			METRIC SYSTEM		
Bolt Size	Grade 5	Grade 8	Bolt Size	Class 8.8	Class 10.9
5/16	180 in-lbs	240 in-lbs	6MM	60 in-lbs	108 in-lbs
3/8	30 ft-lbs	35 ft-lbs	8MM	216 in-lbs	23 ft-lbs
7/16	45 ft-lbs	60 ft-lbs	10MM	32 ft-lbs	45 ft-lbs
1/2	65 ft-lbs	90 ft-lbs	12MM	55 ft-lbs	75 ft-lbs
9/16	95 ft-lbs	130 ft-lbs	14MM	85 ft-lbs	120 ft-lbs
5/8	135 ft-lbs	175 ft-lbs	16MM	130 ft-lbs	165 ft-lbs
3/4	185 ft-lbs	280 ft-lbs	18MM	170 ft-lbs	240 ft-lbs
Above Specifications Are Not to Be Used When Bolt Is Being Installed With a Bushing.					

Seat Belts Save Lives. Please Wear Your Seat Belt.

SKYJACKER

SUSPENSIONS

SKYJACKER.COM

Check Out Our Favorite Ministries at:

- innministries.org
- familychurch.org
- kcm.org

Jesus Christ Died For You.

John 3:16

For God so loved the world that He gave His only Son, so that everyone who believes in Him should not perish, but have everlasting life.

Romans 3:23

For all have sinned; all fall short of God's glorious standard.

Ephesians 2:8

God saved you by his special favor when you believed. And you can't take credit for this; it is a gift from God.

Psalms 18:2

The Lord is my Rock, my fortress, and my savior; my God is my Rock, in whom I find protection. He is my shield, the strength of my salvation, and my stronghold.

Romans 10:9-10

That if you shall confess with thy mouth the Lord Jesus, and shall believe in your heart that God hath raised him from the dead, you shall be saved. For with the heart man believeth unto righteousness; and with the mouth confession is made unto salvation.

Pray This Simple Prayer:

God, I come to You admitting I have sinned against You and I need you to take control of my life. The Bible says anyone who calls on the name of the Lord will be saved.

I am calling on You, Jesus. I ask that You come live in my heart and be the Lord over my life today. I do believe You died on the cross for me and came back to life to give me life! Thank You, Lord Jesus for a new life in You! Amen.

Now, go and tell somebody about your new life in Jesus, get a Bible, begin to read it, and go to a Bible believing church.

If you would like someone to pray with you, call Kenneth Copeland Ministries anytime at 800-600-7395.

To listen to commercial free Christian radio on the web, go to www.887fm.org



**JESUS
FORGIVES
ROCKS
DON'T**

Jesús murió por ti.

Juan 3:16

Porque tanto amó Dios al mundo, que dio a su Hijo unigénito, para que todo el que cree en él no se pierda, sino que tenga vida eterna.

Romanos 3:23

Pues todos han pecado y están privados de la gloria de Dios.

Efesios 2:8

Porque por gracia ustedes han sido salvados mediante la fe; esto no procede de ustedes, sino que es el regalo de Dios.

Salmos 18:2

El Señor es mi roca, mi amparo, mi libertador; es mi Dios, el peñasco en que me refugio. Es mi escudo, el poder que me salva, ¡mi más alto escondite!

Romanos 10:9-10

Que si confiesas con tu boca que Jesús es el Señor, y crees en tu corazón que Dios lo levantó de entre los muertos, serás salvo. Porque con el corazón se cree para ser justificado, pero con la boca se confiesa para ser salvo.

Ahora dí esta simple oración:

Dios, vengo a Ti y admito que he pecado contra Ti, necesito que tomes el control de mi vida. La Biblia dice que todo aquel que invoca el nombre del Señor escapará con vida. En este momento yo clamo ante Ti, Jesús; te pido que vengas a vivir en mi corazón y que tomes el control de mi vida. ¡Yo creo que tu moriste en la cruz y resucitaste para darme vida! ¡Gracias Señor Jesús, por una nueva vida que tengo en Ti! Amén.

Ahora ve y dile a alguien sobre la nueva vida que tienes en Cristo. Compra una Biblia y empieza a leerla. Busca una Iglesia que cree en la Biblia y hazte parte de esa Iglesia.

Si te gustaría orar con alguien, puedes llamar a este número 800-600-7395

Puedes ir a este sitio de Internet para escuchar música Cristiana sin anuncios, www.887fm.org

