

TRUXEDO
TRUCK BED COVERS

Damaged or missing parts? Call 877-878-9336 Mon - Fri 8 a.m. - 5 p.m. CT. Parts will be shipped to you factory direct. Do not return kit to place of purchase. To view install video visit truxedo.com/lopro

PARTS INCLUDED IN YOUR KIT:

- A** Driver side rail
- B** Passenger side rail
- C** Cover assembly
- D** 6x clamps
- E** Bulkhead seal (on select make/models)
- F** 2x Hex Nuts
- G** 2x Plastic washers
- H** 2x Square Head Screws

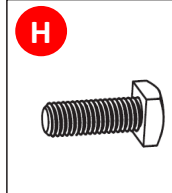
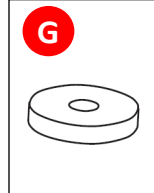
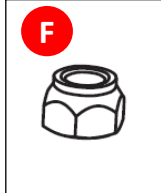
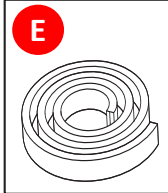

The serial number for the cover is located here. For future reference, write it here: _____

1 Remove the rear cargo rail end plugs and remove the cargo tie down if installed.



2 Assemble clamps as shown below.

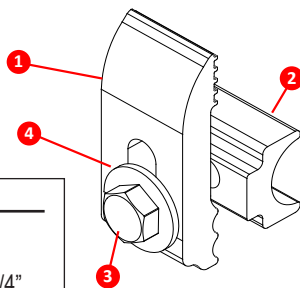

Item	Part #	Description
1.	1706408	MALE CLAMP
2.	1703889	FEMALE CLAMP
3.	1701208	CAP SCREW 5/16" X 1 1/4"
4.	1700428	FLAT WASHER 5/16"

3 Slide clamps into cargo rail as shown below. Evenly space the clamps (see step 4). Tie down cleats can be reinstalled at this time, if desired. Leave clamps loose at this time. Reinstall cargo rail end plugs.

Repeat steps 1-4 for passenger side clamp installation.

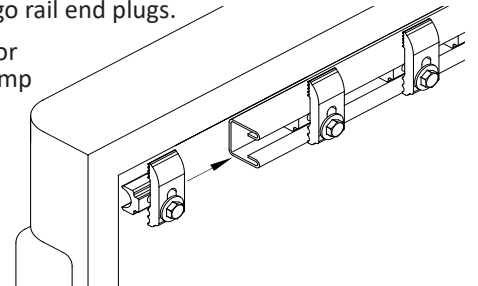

4 Position clamp here Position Rear tie down here Position Front tie down here Position clamp here

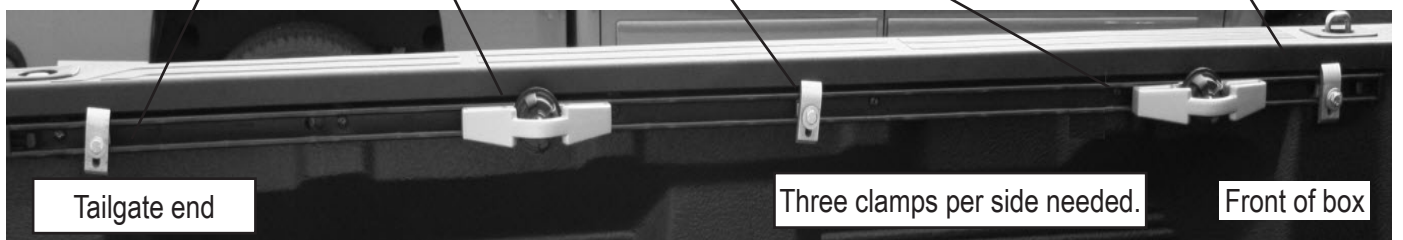

SIDE RAIL INSTALLATION

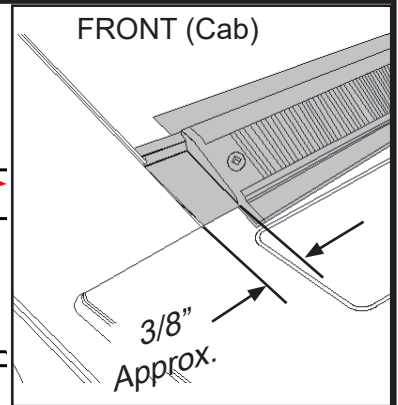
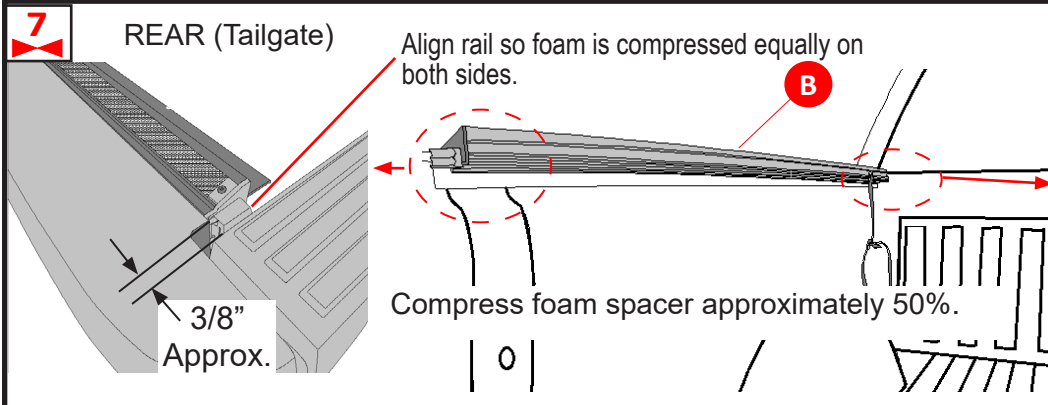
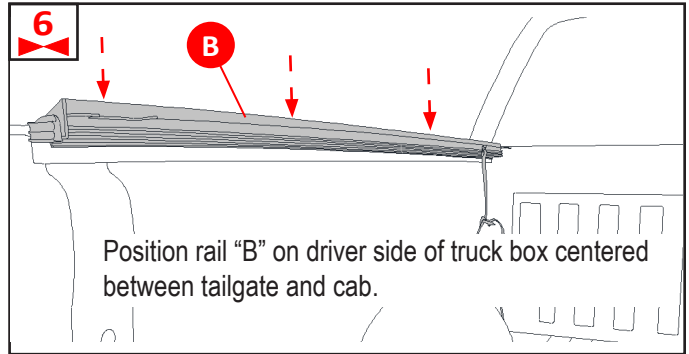
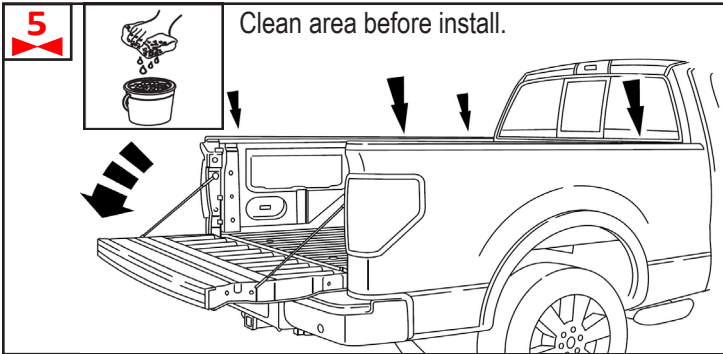

ATTENTION: RAIL SITS ON TOP OF TRUCK'S BED RAIL.

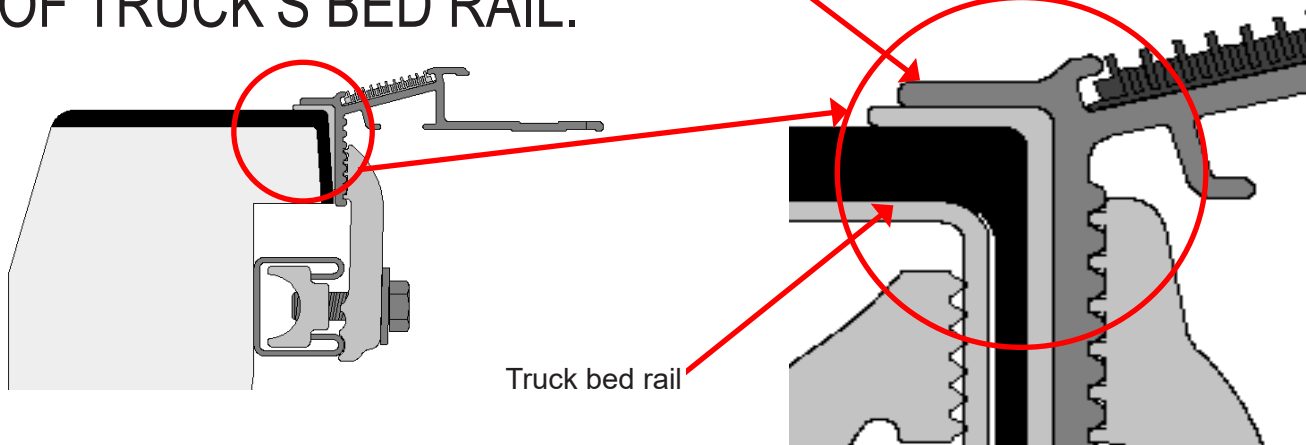

Rail Sits on Top of Bed Rail

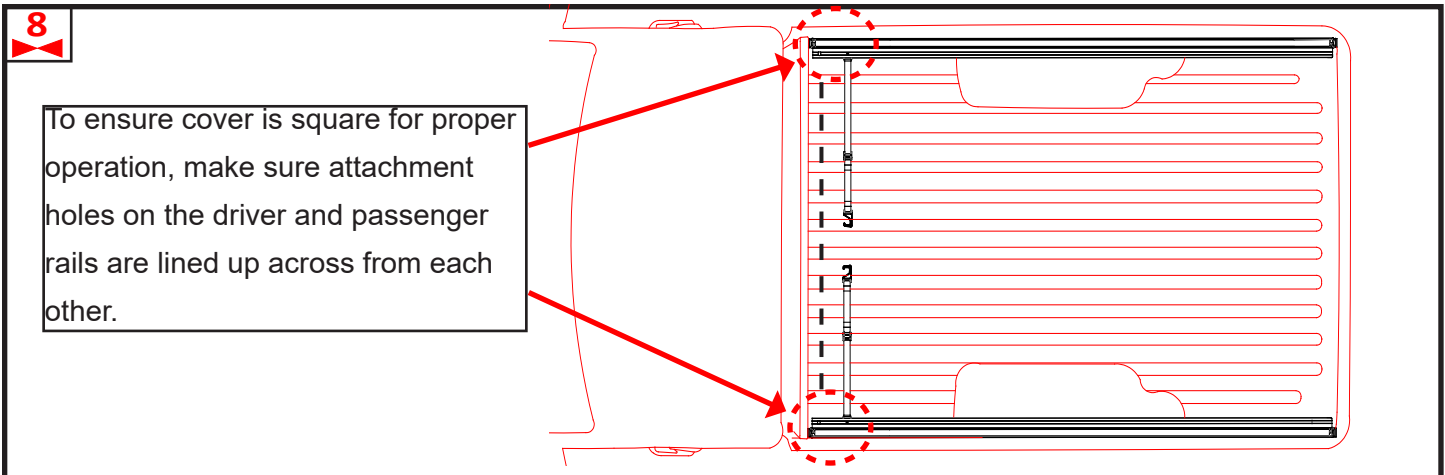

9 For optimal latching performance and cover fit, the side rails (A & B) should be level with the truck bed caps and not tilted up or down. Tighten all clamps with a 1/2" wrench or socket.

WARNING
Tighten clamps securely on side rails before driving vehicle.

10 Repeat steps 2-5 on passenger side for item C. When finished proceed to step 7.

COVER ASSEMBLY INSTALLATION

11 If included with your cover, clean the top of the bulkhead to install the bulkhead seal (E). Peel the backing and adhere the seal from one bedrail edge to the other. Remove any excess with scissors or a utility knife. If the truck has a drop in bedliner, no seal will be ne

12 On the cover assembly (A), identify the driver and passenger front header end plugs. Remove both plugs by pulling them outward as shown below.

13 Install the bolts (H) by sliding them into the header as shown below. Do this on both driver and passenger sides.

14 Reinstall both end plugs as shown below.

15 Place the cover (A) on the side rails towards the front of the truck bed (near the cab). Rotate the front header down so the square head screws align with the oblong holes punched in the side rails.



16 The front header seal is designed to sit on top of the front bulkhead and help shed water. Attach and tighten washer (G) and nut (F) to the square head screws as shown.

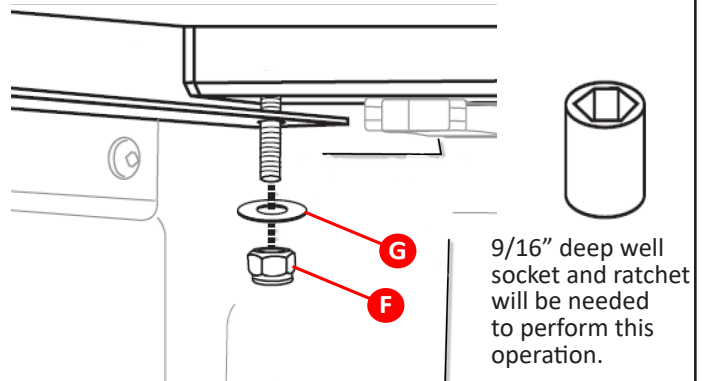
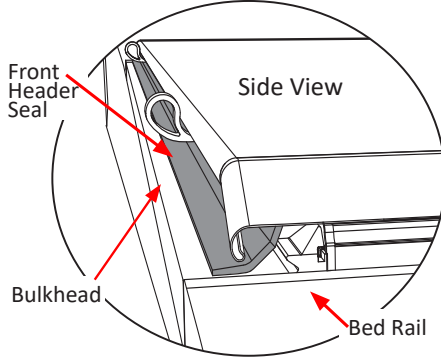

CLOSING THE COVER

17 Unroll cover to the tailgate.

CAUTION
PINCH POINTS
CAN CAUSE SERIOUS
PERSONAL INJURY

CAUTION HIGH TEMPERATURE
IN BRIGHT SUN AND OR HEAT

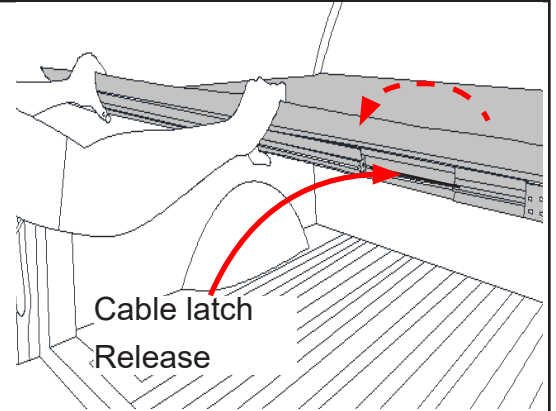
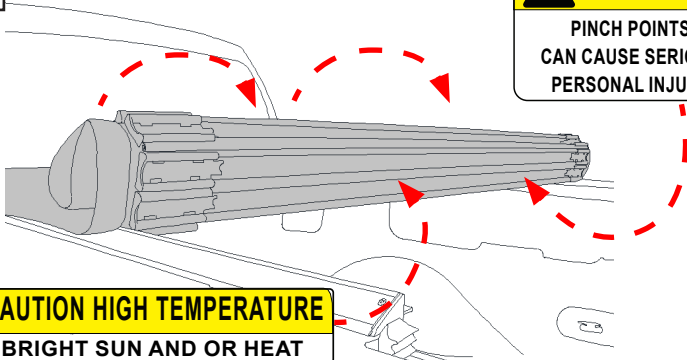

18 Latch Both Sides.

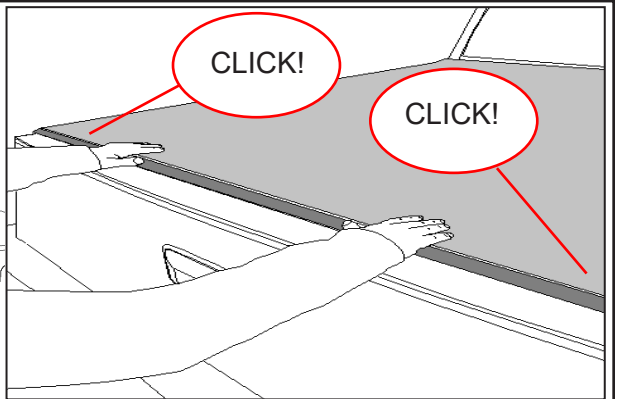
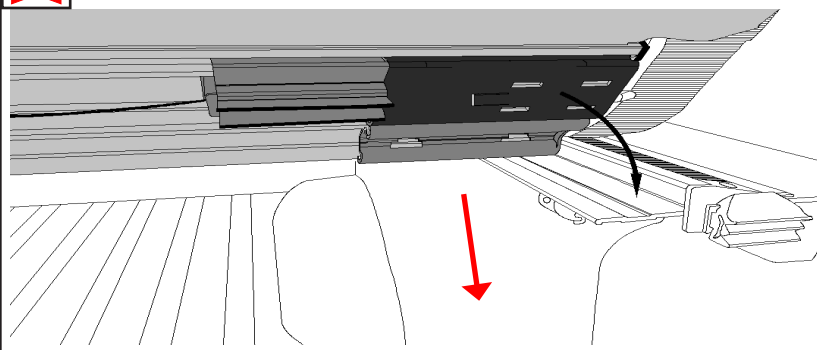

19 PREFERRED METHOD OF CLOSURE: Close tailgate, then close cover on top of tailgate. This method will not work with some truck applications. Use alternate method instead.

ALTERNATIVE METHOD OF CLOSING COVER: Close and latch cover, then close tailgate with the seal to the inside of the tailgate. Some care will need to be taken to train seal to be closed on the inside.

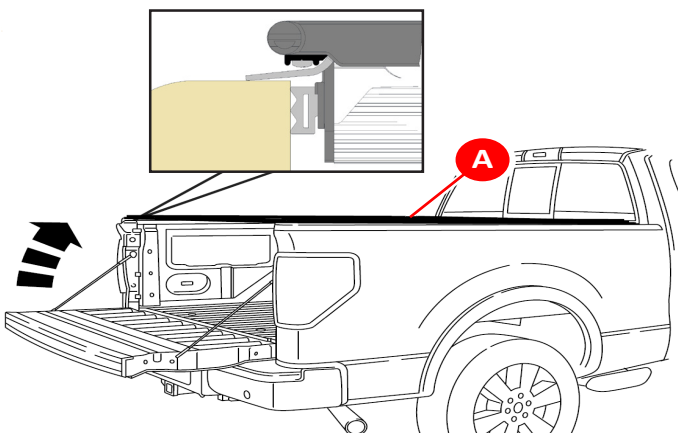

NOTE: If you have a key lock tailgate, truck bed cover is secured until tailgate is unlocked and opened.

CAUTION Make sure cover is securely latched on both sides before operating vehicle.



20 To secure the hook and loop grab the fabric and pull evenly over the hook track to engage the hook and loop.

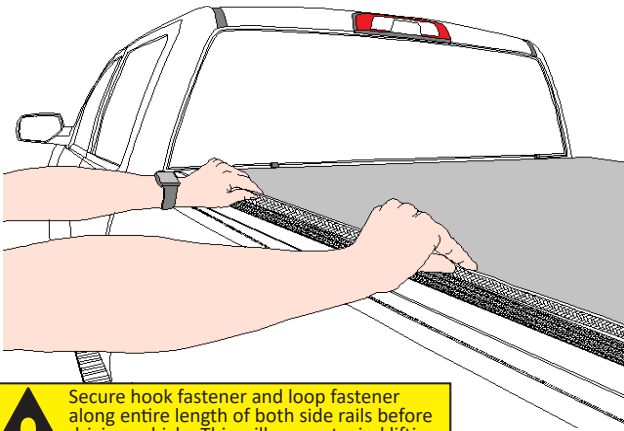

! Secure hook fastener and loop fastener along entire length of both side rails before driving vehicle. This will prevent wind lifting the cover and causing damage.

21 Once the side of the hook and loop are engaged, use the palm of your hand to firmly push the loop strip into the hook track the entire length of the cover. This will prevent wind from lifting the cover and causing possible damage. Do this on both driver and passenger sides.

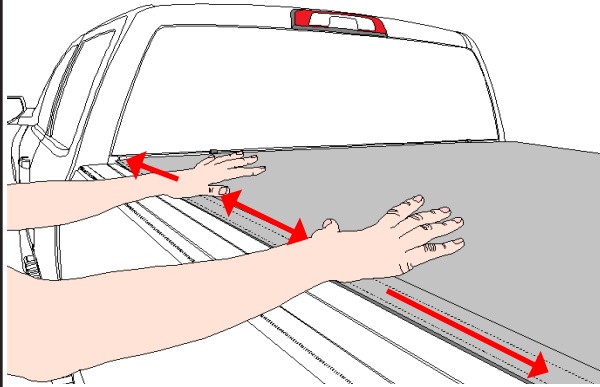

ATTENTION!

After the initial installation leave cover closed and latched for a 24 hour period. This will ensure that the fabric has taken a complete set to the metal substrate.

OPENING THE COVER

22 To open cover, pull down on release cable and hold down. Lift and roll rear header.

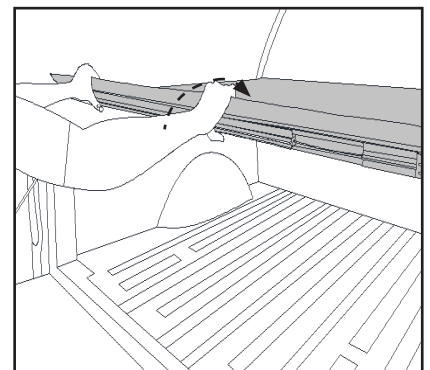
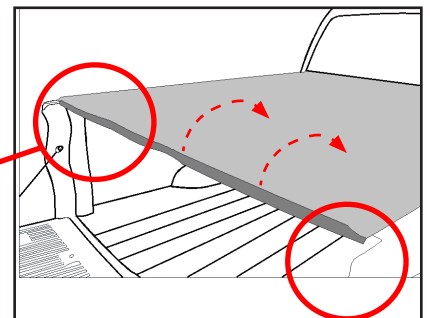
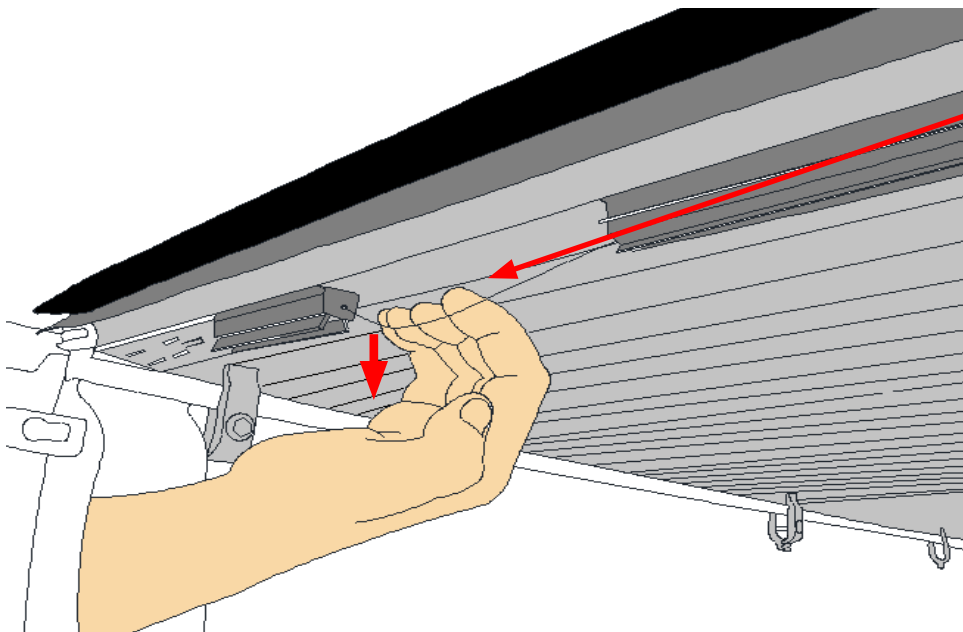

23 To drive with the cover in the open position, secure the cover by placing both retainer hooks into the retainer loops. **You are ready to drive with the cover in the open position.**

CAUTION

ROLL COVER TIGHT. SECURE THE COVER APPROPRIATELY USING BOTH RETAINER STRAPS. **DO NOT** OVERTIGHTEN. **DO NOT** STOW COVER AGAINST CAB WINDOW.

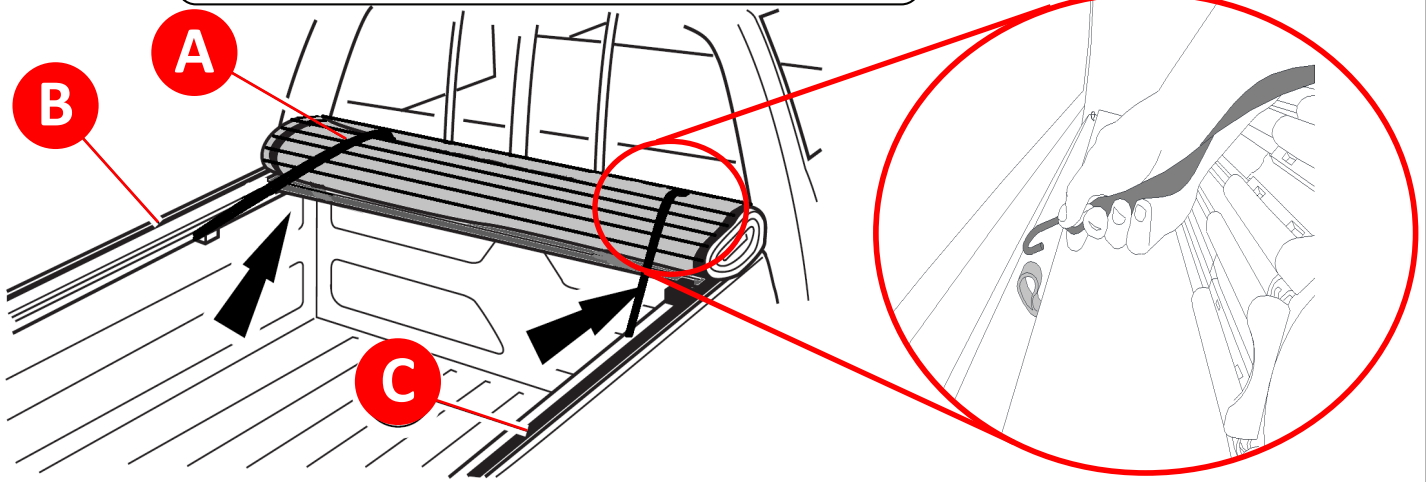

CAUTION

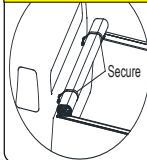

Before driving with cover open, **BOTH STRAPS MUST BE SECURED TO RETAINING LOOPS.** Failure to do so could cause accidental release of the cover, resulting in personal injury or property damage.

24 To Release Strap Push Tab Up.

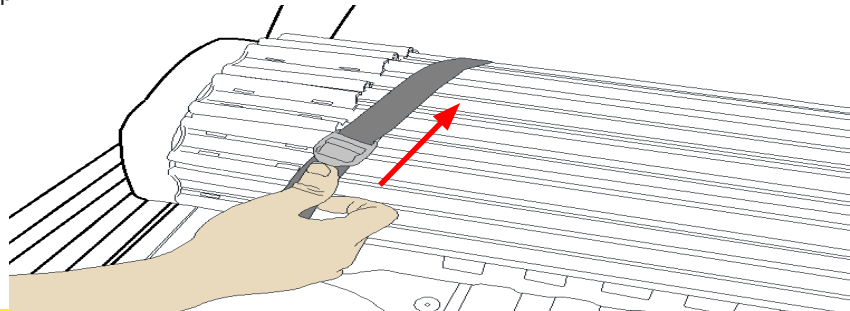

NOTICE: Ice buildup within hinge section can occur if cover is stowed in open position. To prevent potential damage, close cover during winter precipitation.

COVER MAINTENANCE

1. Cover surface can be hand washed with mild soap and water or cleaned in a car wash. Thoroughly rinse cover to remove any soap residue. **Never use vinyl conditioners that contain silicon, petroleum, or citrus based products on your truck bed cover as they may crack and shrink the vinyl top surface.**
2. The use of a power washer directed at the covers top surface from a few inches away will damage the surface. The nozzle end of a power washer should be held at a minimum of 3 feet away from the top surface.
3. It is recommended that you periodically check that the cover is securely attached to your truck bed. Inspect the clamps and front header guide slides to ensure they were properly installed and have not come loose during operation.
4. It is recommended that you periodically inspect and service the rear latch closures. Clean away any excess dirt or grime and lubricate with silicone spray. Ensure the latches move freely in and out to properly engage the side rail and provide performance with optimal security. Be careful not to overspray the cover.

Questions?

Call our friendly customer service staff
Toll Free at:

1-877-878-9336
Mon - Fri 8 am - 5 pm CST



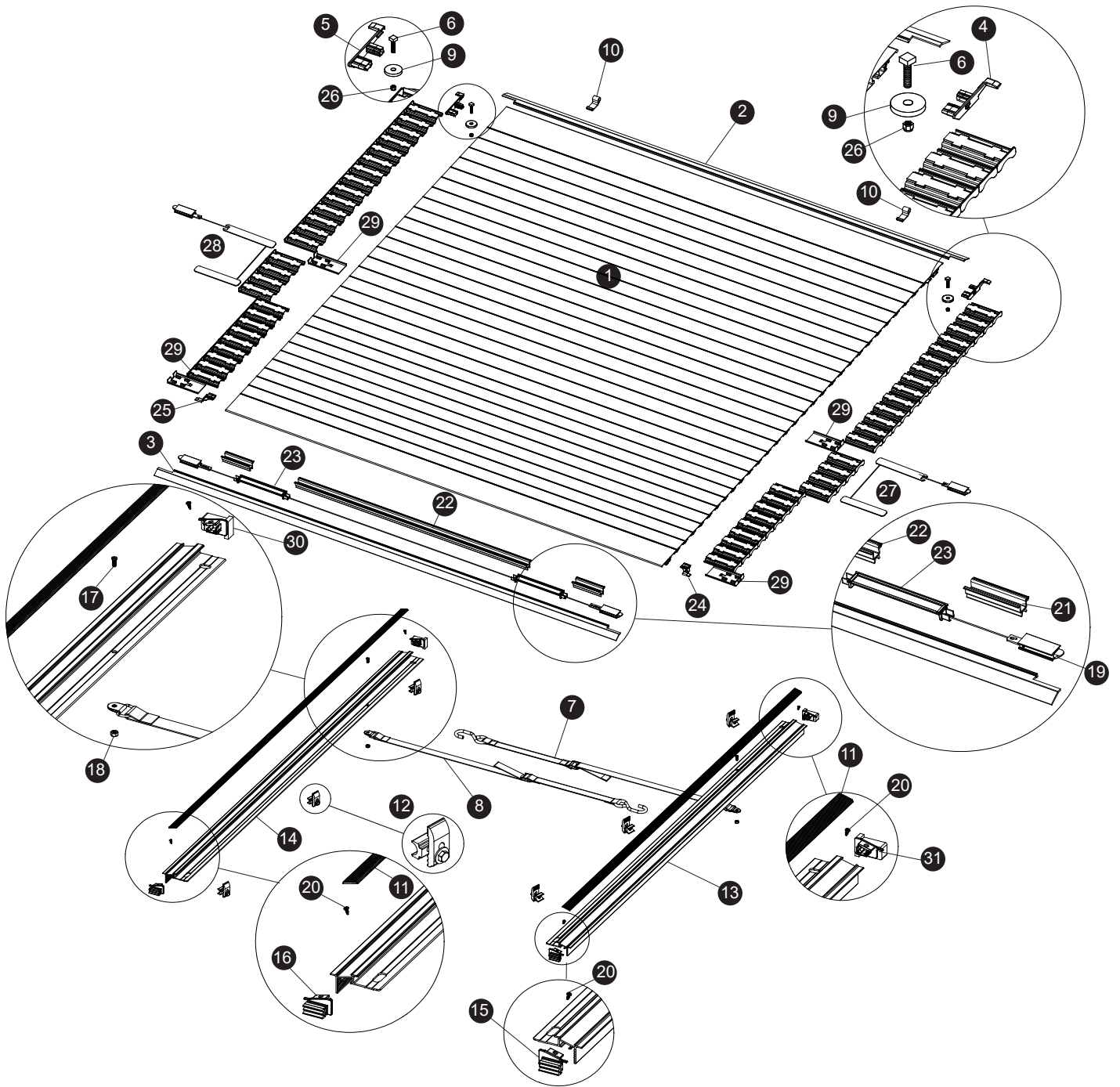

TOYOTA TUNDRA SENTRY / SENTRY CT REPLACEMENT PARTS

1	*	Sentry/Sentry CT Replacement Cover	13	*	Side Rail, Passenger's Side	24	1705826	Rear Header End Plug (Passenger)
2	*	Header Seal, Front	14	*	Side Rail, Driver's Side	25	1705825	Rear Header End Plug (Driver)
3	*	Header Seal, Rear	15	1705851	SIDE RAIL END PLUG ASSY_RH	26	1701580	Hex Nut 3/8 Locking
4	1118723	Front Header End Plug (Passenger)	16	1705852	SIDE RAIL END PLUG ASSY_LH	27	*	Passenger Security Latch Assy
5	1118724	Front Header End Plug (Driver)	17	1705415	Cap Screw 10-24 X 1/2	28	*	Driver Security Latch Assy
6	1703455	Cap Screw, Sq. Head 3/8"	18	1703762	Hex Nut 10-24	29	1705929	Latch Cover
7	1117892	Retainer Hook Strap (Passenger)	19	*	Latch System	30	1118243	Side Rail End Plug_RH Foam Seal
8	1117893	Retainer Hook Strap (Driver)	20	1705629	Self Drill Screw 6-20 X 3/8	31	1118244	Side Rail End Plug_LH Foam Seal
9	1115745	Washer 1/4" x 1.50 RD	21	1118225	Cable Cover 3.75"			
10	1705806	Extruded Retainer Loop	22	*	Cable Cover			
11	*	Hook and Loop Fasteners	23	1115822	Cable Guard			
12	1706843	Aluminum Clamp Assembly						

* Please specify length or make and model of vehicle.

OWNER/USER RESPONSIBILITIES:

It is the responsibility of the owner/user to read this manual and comply with the operating procedures. The owner/user is also responsible for inspecting the Sentry/ Sentry CT cover and for having parts repaired or replaced when worn or damaged. Failure to follow safety instructions and warning labels could result in failure of your cover system and/or personal injury.

SAFETY INSTRUCTIONS:

1. Do not place objects on or against cover or framework.
2. Do not tie cargo to truck bed cover framework.
3. Never allow children or pets to occupy pickup box while cover is closed.
4. Cover is not airtight. Special care is required to keep cargo clean and dry.
5. Fabric cover won't prevent theft of contents inside truck box.
6. Cover must be rolled fully open and secured with retainer straps when towing vehicle backwards.
7. DO NOT stow rolled cover against cab window.
8. DO NOT attempt to drive with cover in the partially open position!
9. A fully rolled open cover must always be secured with retainer straps.
10. DO NOT operate vehicle with objects on top of the cover.

ADDITIONAL IMPORTANT SAFETY TIPS



CAUTION HIGH TEMPERATURE

TOP SURFACE AND BOTTOM SURFACE CAN BECOME EXTREMELY HOT TO TOUCH WHEN EXPOSED TO BRIGHT SUN AND OR HEAT.
NEVER ALLOW CHILDREN OR PETS TO SIT ON COVER WHEN CLOSED OR ROLLED TO THE CAB.



CAUTION

ROLL COVER TIGHT. SECURE THE COVER APPROPRIATELY USING BOTH RETAINER STRAPS. **DO NOT** OVERTIGHTEN. **DO NOT** STOW COVER AGAINST CAB WINDOW.

IMPORTANT OPERATING TIPS

- Truck bed cover must be free of foreign material including snow and ice before rolling cover open or closed.
- It is recommended to operate vehicle with cover rolled closed and latched for optimal fuel economy.
- After closing cover make sure hook and loop on both sides are engaged.
- If side rails are tipping, clamps can be adjusted to level the rails to ensure proper cover header fitment.
- Prolonged cold weather will make cover fabric stiff. Move vehicle with cover unrolled and latched into the sun or indoors to warm the top surface.
- If cover has been stored in a rolled up state for a long period of time it may take a few minutes for the cover to lay flat. The fabric material needs to relax to a flat state, this is normal.
- **DO NOT** roll cover into rear cab window. **DO NOT** stow rolled cover against cab or cab window.
- Modification of accessories such as bed liners (including spray in liners) may be necessary allowing the truck bed cover side rails to fit properly between the front bulkhead and tailgate of the truck bed.



IMPORTANT OPERATING TIPS CONTINUED:

- After the initial installation leave cover closed and latched for a 24 hour period. This will insure that the fabric has taken a complete set to the metal substrate.

- **INCORRECT METHOD** Of How To Open Cover To The Front.

- Do not slide a partially opened cover across the cover's surface.
- Do not slide cargo across the cover's surface.
- Do not store items on cover's surface.



- **CORRECT METHOD** Of How To Open Cover To The Front.

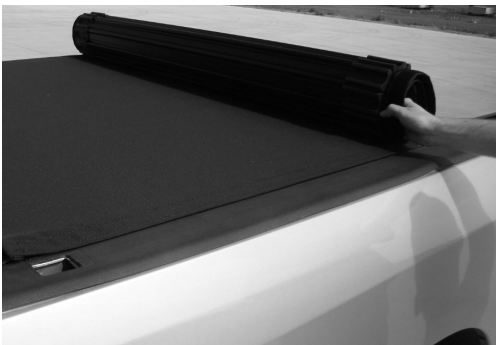

- **AFTER INITIAL INSTALL**

Cover Tracking Marks: The cover will experience slight tracking marks from dust deposited on the top surface even after the first initial roll out. If there is a heavy deposit of dust, simply use a wet rag to wipe the top surface of the cover clean.

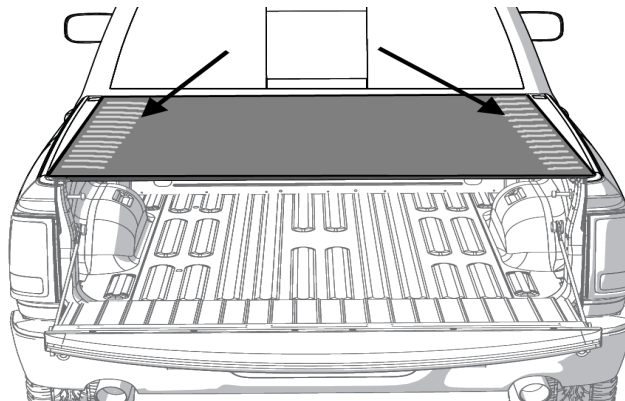

- **DAY TO DAY USE**

Cover Tracking Mark Prevention: All truck beds will accumulate road dust. This dust will accumulate on the side rails and adhere to the underside of the truck cover. When the truck cover is rolled open, the underside of the cover can deposit dust onto the top surface. To prevent dust-tracking marks, periodically clean the side rail surfaces, rubber slat end caps, and underside surface of the cover to remove dust build up. Plugging air holes and gaps in the truck box construction will also greatly reduce dust intrusion into the truck box. Periodically cleaning the top surface with soap and water will also help prevent dust-tracking marks.

IMPORTANT OPERATING TIPS CONTINUED:

- SETTING THE HOOK AND LOOP BEFORE OPERATING VEHICLE.

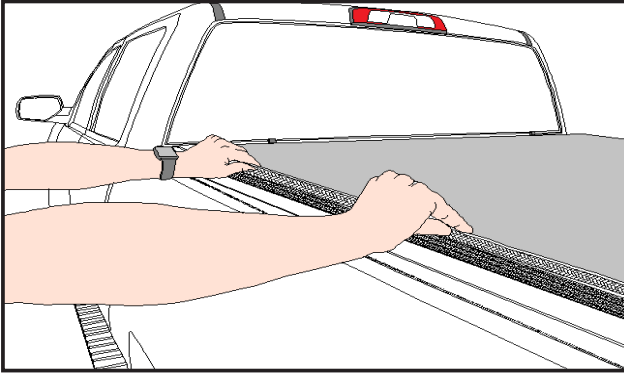

Engaging Hook and Loop, Step One: After rolling the cover closed, grab the fabric loop flap and evenly pull loop over the hook track engaging the loop to the hook track. **Avoid pulling fabric flap straight up.**

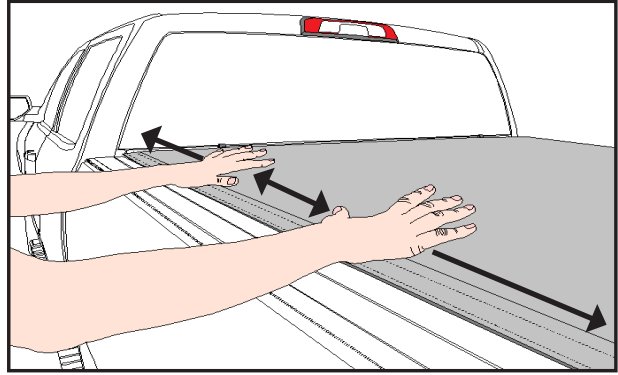

Engaging Hook and Loop, Step Two: With the cover closed and both hook and loop engaged, use the palms of your hand to firmly push the loop strip into the hook track. Do this to both driver and passenger side up and down the entire length of the loop seams.

TROUBLESHOOTING

COVER ASSEMBLY WILL NOT ATTACH TO SIDE RAILS DURING INSTALLATION:

1. Check side rails to make sure they are level.
2. The rolled up cover is heavy which may be flexing the rails downward. Push front of rail up slightly to allow the screw head to fall in the oblong holes. (review steps 15 and 16).
3. If rear header doesn't latch correctly check side rail installation.

HEADER WILL NOT LATCH:

1. Check side rails to make sure they are level.
2. Make sure the rear header seal is not caught between side rail & rear header.
3. If rear header doesn't latch correctly check side rail installation.
4. Check to make sure side rails are both equally spaced front to rear.
5. Make sure both latches are functioning properly. Clean any debris that may be impeding latches, see COVER CARE AND MAINTENANCE on page 6.
6. Close tailgate first then cover.

COVER IS HARD TO ROLL OPEN OR CLOSED:

1. Truck bed cover MUST be free of foreign material including snow and ice before rolling cover.
2. Prolong cold weather will make cover fabric stiff. Move cover into sun or indoors to warm the top surface.
3. It is normal for the cover to experience light binding after being rolled up for an extended period of time. Once the cover is latched, the fabric will relax and the cover will lay flat.

SENTRY: 3 YEAR WARRANTY

SENTRY CT: 5 YEAR WARRANTY

TruXedo, Inc. warrants that all new, unused products are free from defects in material and workmanship. This Limited Warranty is effective if the product is properly installed and used for the purpose intended. It applies to the original buyer only. TruXedo's obligation under this Warranty is limited to repairing, or at its option, replacing any part that is returned, transportation prepaid, to TruXedo, Inc., Yankton, South Dakota, if the product is, in our judgment, defective. All materials must be accompanied by an RMA (Returned Material Authorization) number requested by and authorized in advance of returning the materials. TruXedo, Inc. shall not be liable or responsible to supply or pay labor to replace any part found defective, nor shall it be liable for any damages of any kind or nature to person, product, or property. There are no Warranties for used products or products that have been repaired, altered, modified, subjected to misuse, negligence, accident or ordinary wear and tear. Warranty registration must be on file and/or proof of original purchase (detailed and dated receipt) required for warranty to be valid. Please locate the serial number on your cover before registering the warranty. The serial number can be found on the underside of the front aluminum header bar located on the driver side. Register warranty online at www.truxedo.com

DIRECT ALL WARRANTY CLAIMS TO TRUXEDO AT 1-877-878-9336

