

Any damaged or missing parts?

Parts will be shipped to you directly.

Call 877-878-9336, Mon - Fri, 8:00 a.m. - 5:00 p.m. CT

NOTE: It is important that all areas where the bed cover mounts are clean and free of debris prior to installing.

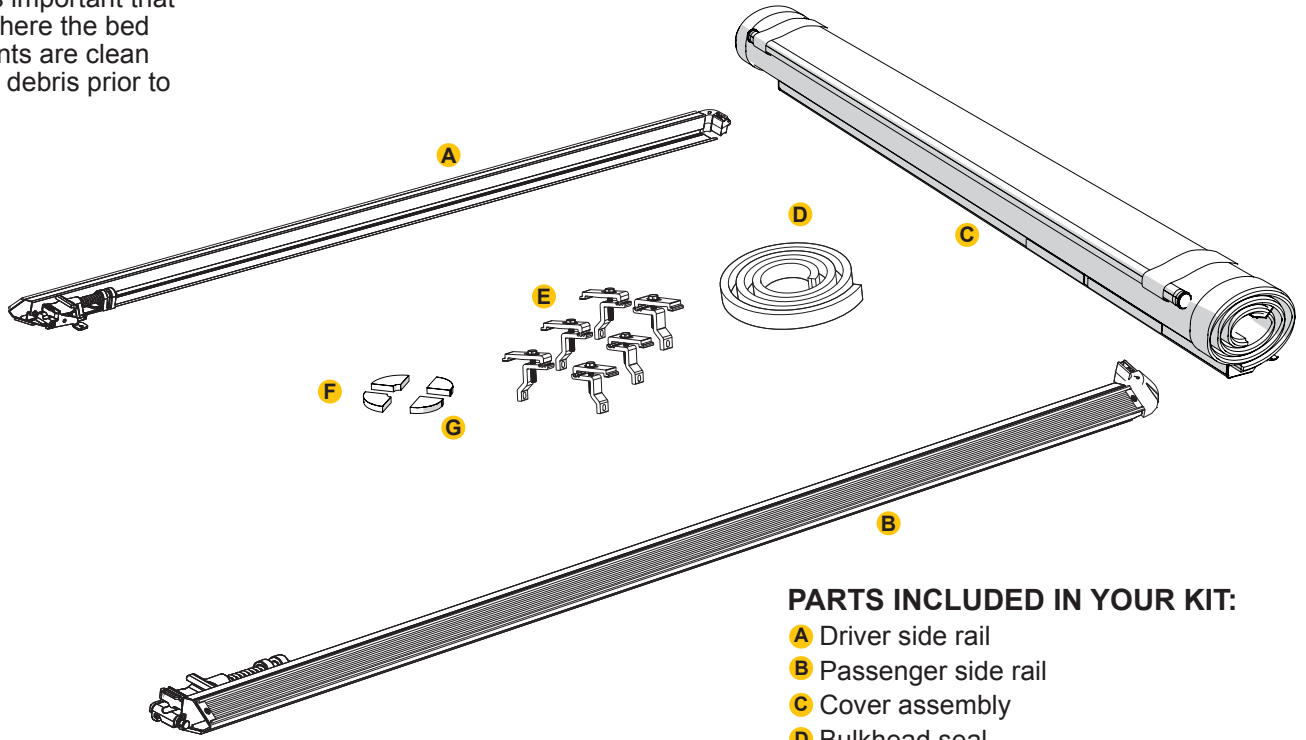

PARTS INCLUDED IN YOUR KIT:

- A** Driver side rail
- B** Passenger side rail
- C** Cover assembly
- D** Bulkhead seal
- E** 6x Clamps
- F** 2x Cab corner seals
- G** 2x Tailgate corner seals

TOOLS REQUIRED

- 1/2" Wrench or socket
- T-30 Drive socket or T-handle wrench

TOOLS RECOMMENDED

- Scissors/utility knife
- Isopropyl alcohol

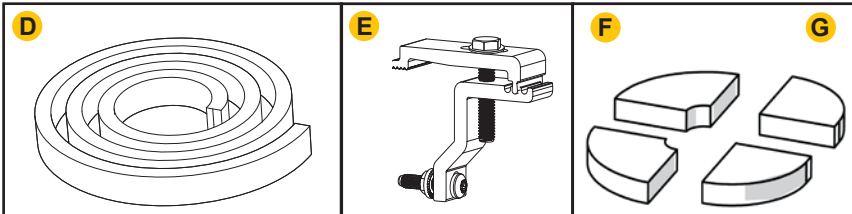

1 The serial number for the cover is located here.

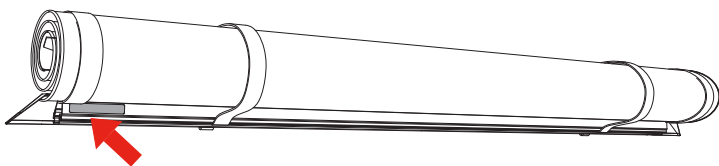

For future reference, write it here:

2 Remove the plastic plugs from the truck's side rail flanges.

NOTE: Store the removed plastic plugs in the glovebox of the vehicle.

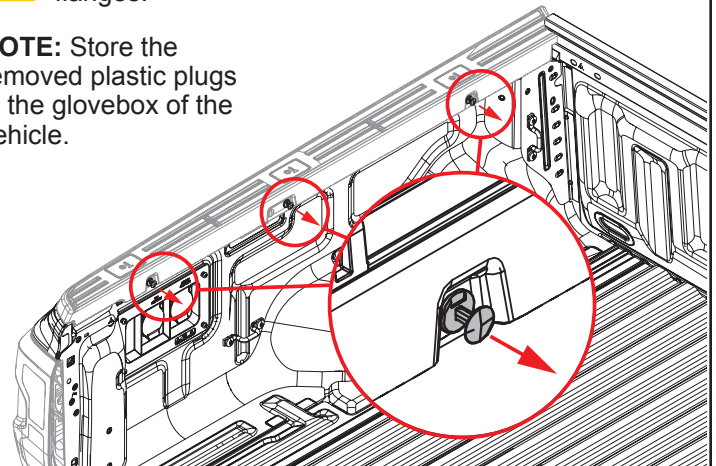

3 Install the bulkhead weather seal (D) to the truck's front bulkhead. Clean the area where the seal will go with soap and water to remove dirt and debris. Then clean the area with isopropyl alcohol to remove wax or grease and to evaporate any remaining water, allow the surface to dry. Then position the seal and apply pressure to the entire seal to make sure the adhesion is good.

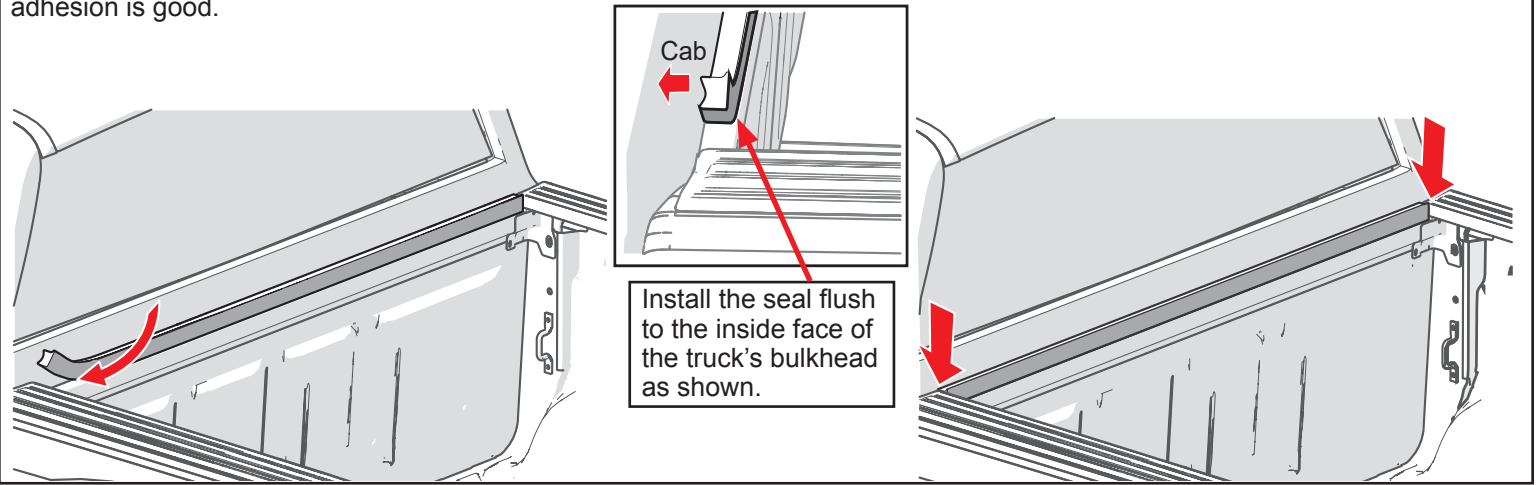

4 Cab corner seals (F) installation:

Clean the area where the seal will go with soap and water to remove dirt and debris. Then clean the area with isopropyl alcohol to remove wax or grease and to evaporate any remaining water, allow the surface to dry. Then remove cab corner seals (F) from the adhesive backing and apply pressure to the entire seal to make sure the adhesion is good. Place both cab corner seals (F) on the driver and passenger side rails (A & B).

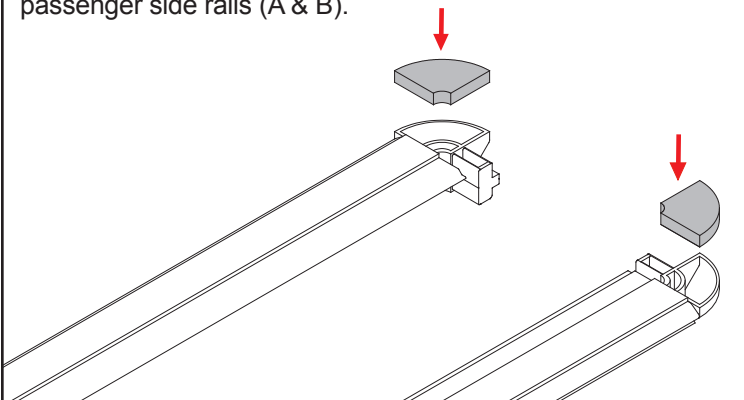

5 Positioning the cover assembly (C) over the front bulkhead: Position the cover assembly (C) near the truck's bulkhead, adjacent to the cab. Ensure that the cover assembly is oriented as depicted and is parallel to the bulkhead.

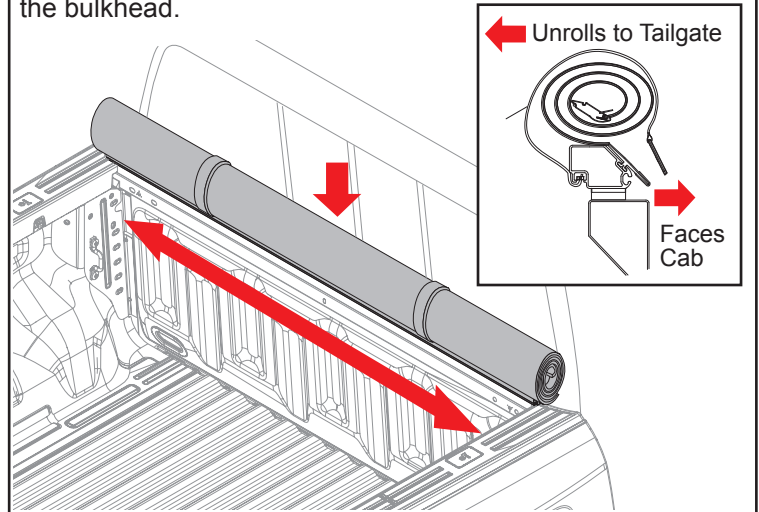

6 To place the side rails (A & B): Place the side rails (A & B) onto the truck bed rails and insert the side rail corner plugs into the front header, take care so the rails do not fall off of the truck and scratch paint.

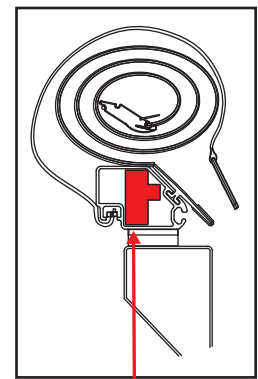
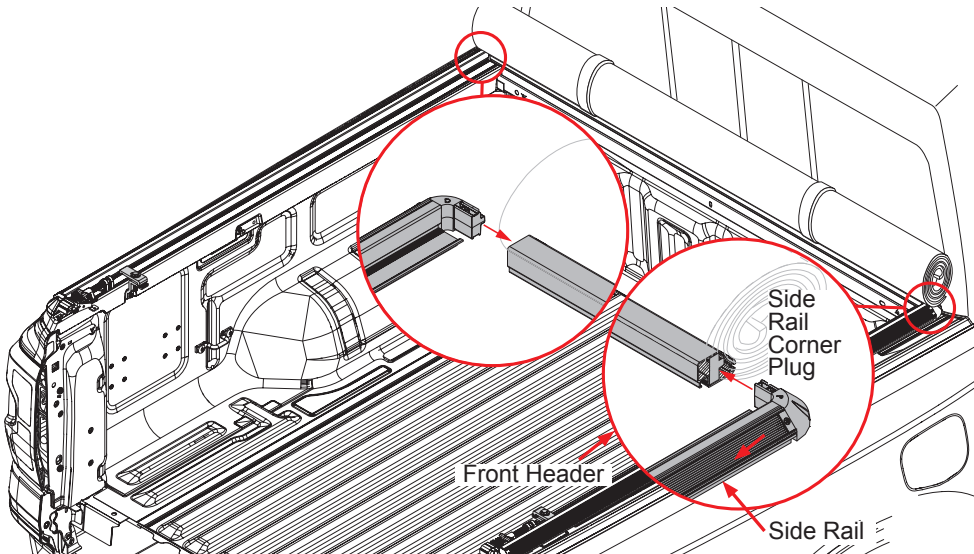

NOTE: Insert side rail into the red shaded area of header guide.

7 Install (3) clamp (E) halves on inside of truck box:

Install three bottom clamp halves (E) to the truck box where you removed the three plastic plugs in step 2 using hardware provided.

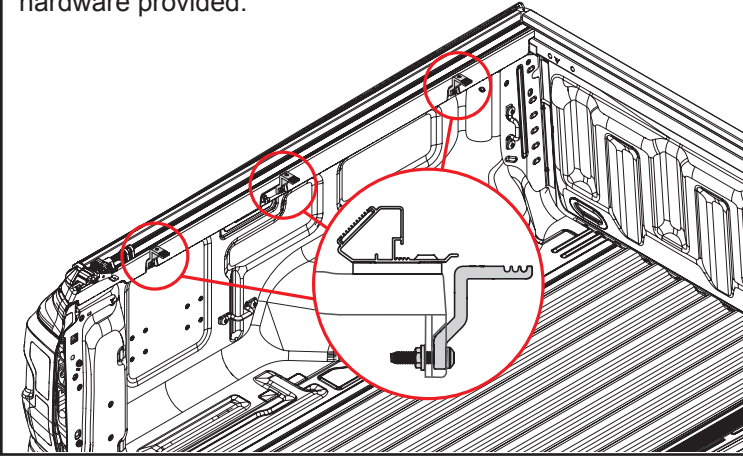

8 Install (3) top halves of clamp (E): Install three top clamp halves (E) to each of the bottom clamp halves (E). Install in the middle setting as shown below.

Installed in middle setting.

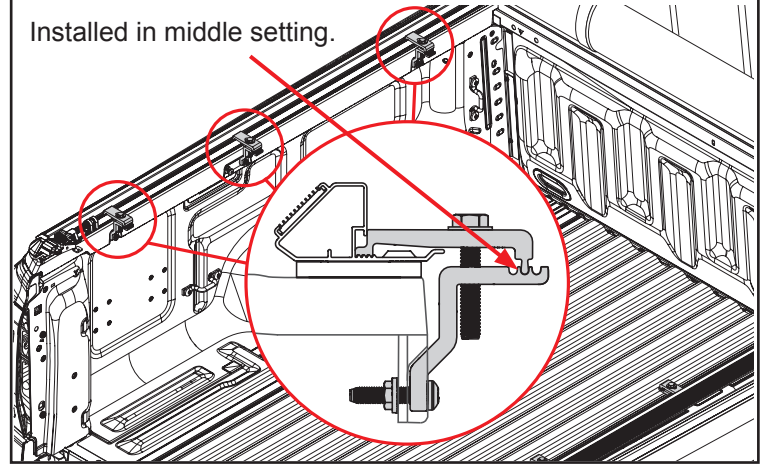

9 Evenly position the cover assembly (C) and rails (A & B) squarely over the truck bed opening. Align front header seal with the inside face of the bulkhead.

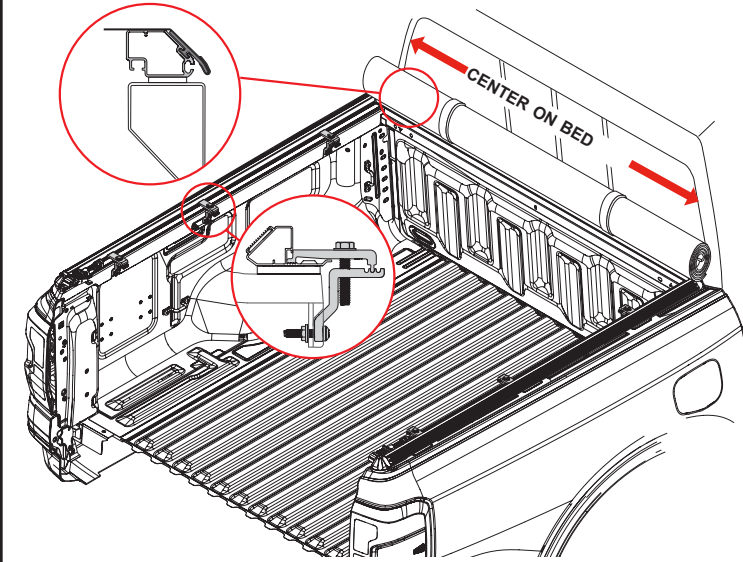

10 Unroll the side rail assembly (C) towards the tailgate. Check that the side rails are centered on the truck bed. **NOTE:** The spacing between the tailgate header and the side rails is 1/8" or 3.2 mm per side.

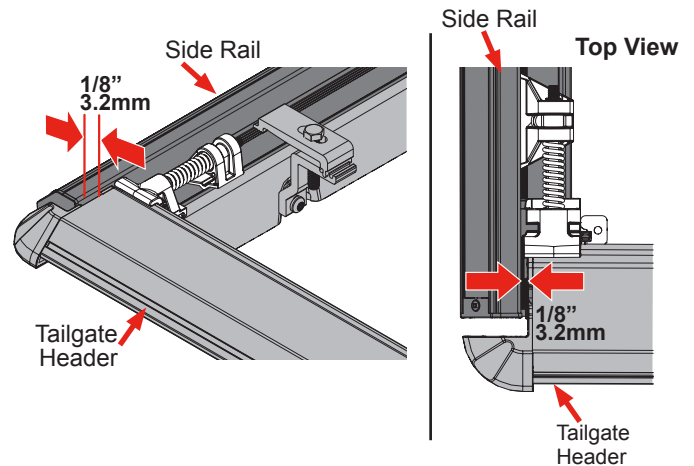

NOTE: The fabric is not shown for clarity.

11 Tighten the front and middle clamps (E). Align the grooves of the clamp with the grooves in the side rail. Do this on both driver and passenger side rails (A & B).

Tighten to 9 Nm, 7ft lb.

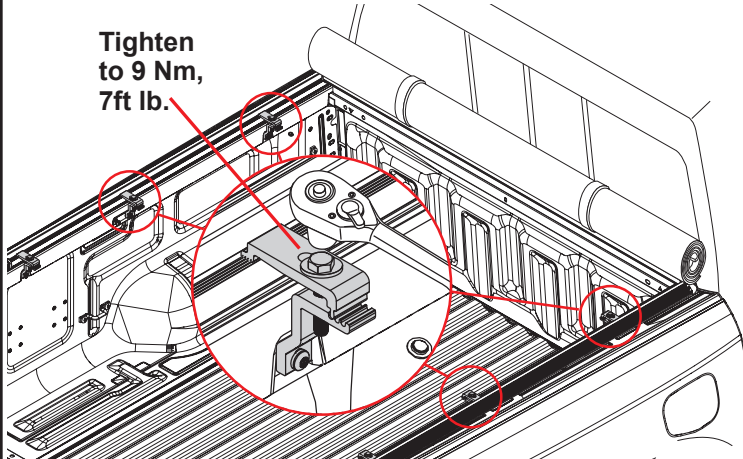

12 Tighten the tailgate clamps (E). Align the grooves of the clamp with the grooves in the side rail. Do this on both driver and passenger side rails (A & B).

Tighten to 9 Nm, 7ft lb.

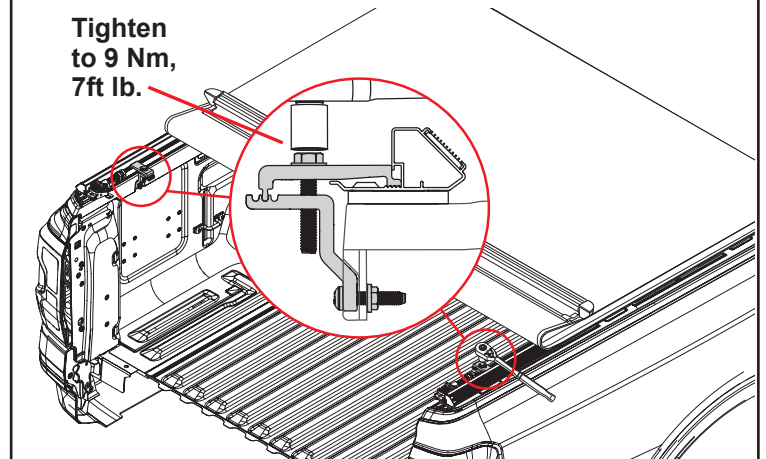

13 Unroll the cover (C) towards the tailgate.

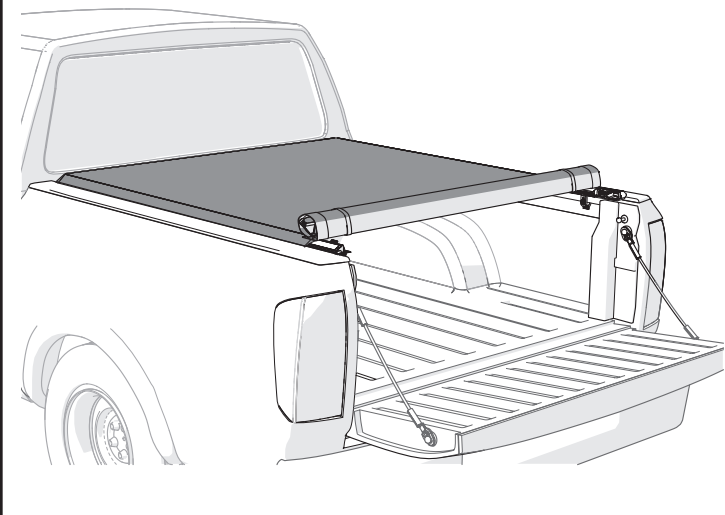

14 Fold back the cover (C) at the tailgate and clean the area where the seal will go with soap and water to remove dirt and debris. Then clean the area with isopropyl alcohol to remove wax or grease and to evaporate any remaining water, allow the surface to dry. Remove the adhesive backing and install tailgate corner seals (G) by applying pressure to the entire seal to make sure the adhesion is good.

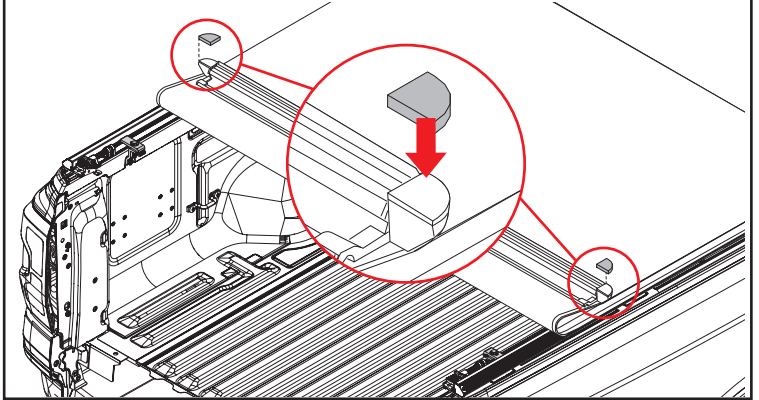

15 **Closing and latching down the rear header:** With the tailgate open and the cover (C) unrolled, hook the tailgate header into the header stops on both sides of the truck. Push the tailgate header down until the latches on both sides engage with the tailgate header. A clicking sound will indicate a secure attachment.

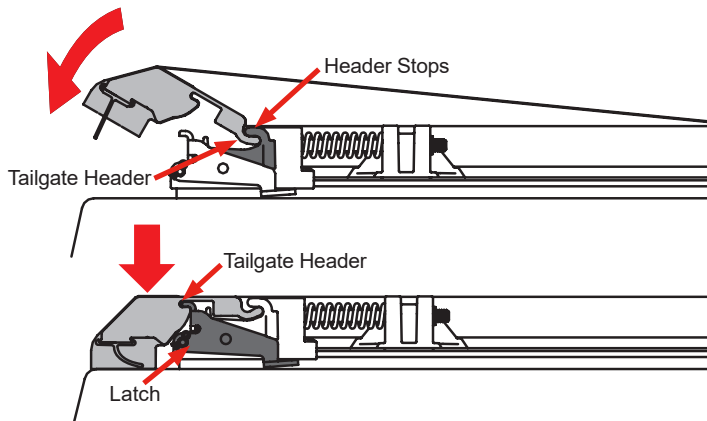

16 **NOTE:** Use two hands when closing cover to make sure the slam latches are fully engaged on both sides.

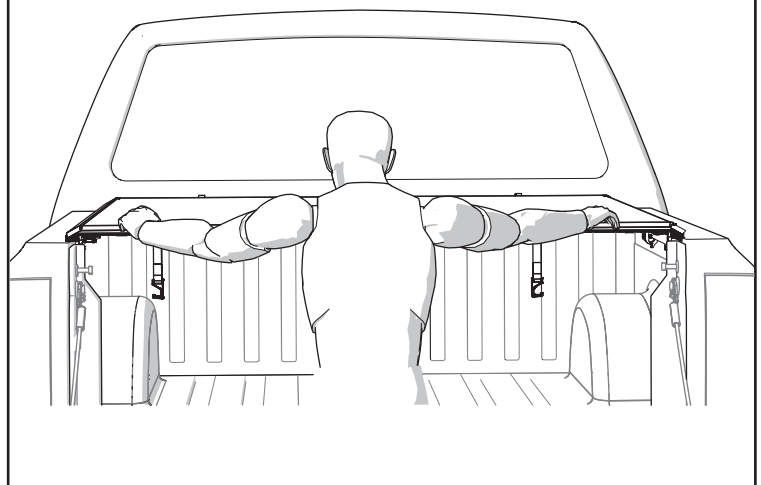

17 **Adjusting the cover (C):** Once the cover is closed, grab the fabric flap and evenly pull it over the hook track engaging the loop to the hook.

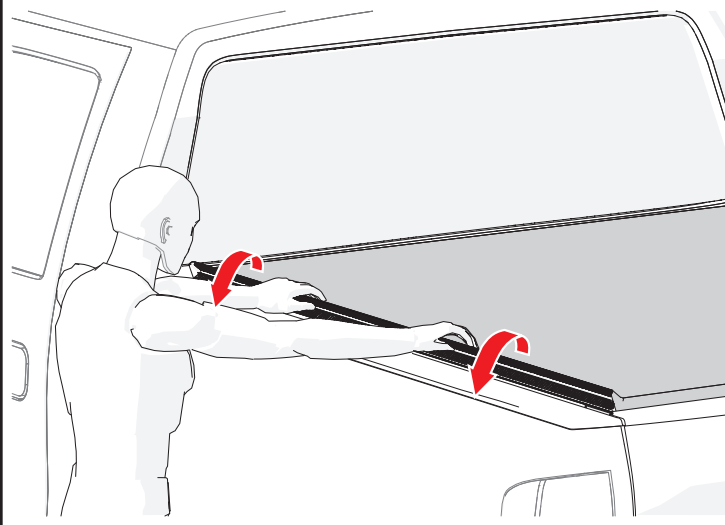

18 **Engaging the hook and loop:** With both sides of the hook and loop engaged, use the palms of your hand to firmly push the loop strip into the hook track. Do this to both driver and passenger sides. **You are ready to drive with the cover (C) in the closed position.**

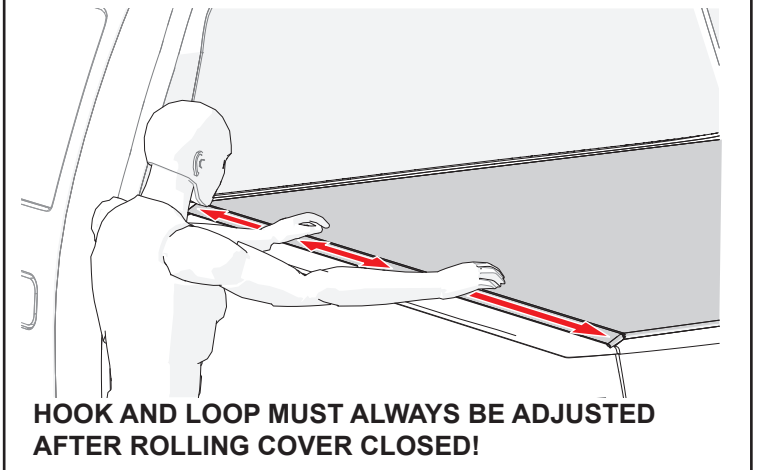

HOOK AND LOOP MUST ALWAYS BE ADJUSTED AFTER ROLLING COVER CLOSED!

OPENING THE COVER

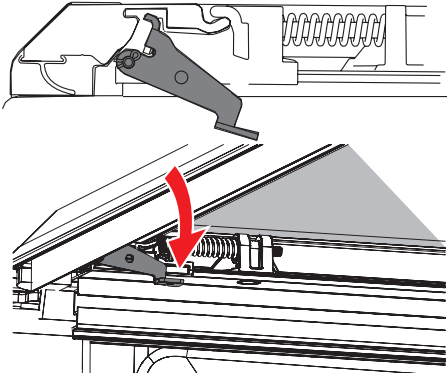

With the tailgate open, press downward on one side latch to disengage.

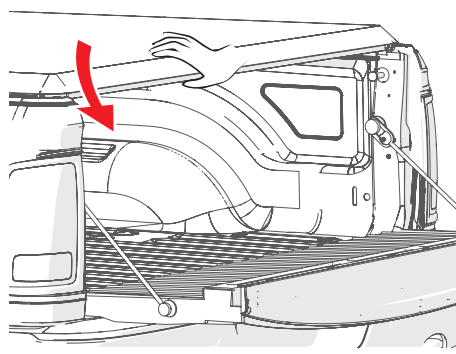

Grasp the tailgate header before releasing the slam latches.

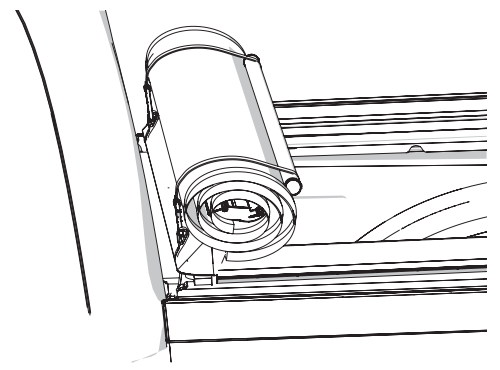

Roll up the cover (C). Do not disengage the hook and loop fasteners before rolling the cover. **Always secure the cover at the front with both retainer straps.**

YOU ARE READY TO DRIVE WITH THE COVER IN THE OPEN POSITION.

PRE-SET TENSION CONTROL

There is no need to adjust cover tension. The latch assembly is already factory set to the correct tension amount. **Any modification done to the latch will void the warranty.**

To keep the cover (C) taut, periodically check the hook and loop and re-stretch the cover fabric across the bed.

Periodically clean the hook and loop and latch with high-pressure water to remove dirt and dust for continued ease of operation.

NOTE: The cover may appear looser or relaxed in cool and cold conditions and tighter in warm and hot conditions.

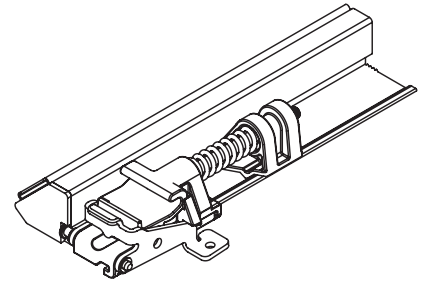

SAFETY INSTRUCTIONS

- DO NOT place objects on or against cover or framework.
- DO NOT tie cargo to truck bed cover framework.
- DO NOT attempt to drive with the cover in the partially open position.
- DO NOT operate the vehicle with objects on top of the cover.
- NEVER allow children or pets to occupy the pickup box while the cover is closed.
- Cover is not airtight. Special care is required to keep cargo clean and dry.
- Tonneau covers won't prevent theft of contents inside the truck box.
- If the cover is going to be rolled open for an extended amount of time, periodically re-roll the cover and secure the retainer straps to ensure the cover doesn't rest against the cab of the truck.
- A fully rolled cover in the open position must always be secured with retainer straps.

TROUBLESHOOTING TIPS

WRINKLES ON THE VINYL FABRIC AFTER ROLLING COVER CLOSED

- Pull the vinyl fabric taut from each side. For best results, the help of a second person pulling on the opposite side is preferable.

WIND LIFTS UP THE EDGE OF THE VINYL FABRIC

- Make sure to engage the hook and loop on the driver and passenger side rails after closing the cover. This may need to be done periodically when taking long trips.

VINYL FABRIC FLUTTERS EXCESSIVELY WHEN DRIVING

- Make sure hook and loop fasteners are set.

SNOW AND ICE ACCUMULATION ON THE VINYL FABRIC

- Use a broom or brush to remove loose snow and ice. DO NOT use sharp or pointed tools to remove snow and ice.
- Direct sunlight will help melt snow and ice off the fabric.

TONNEAU COVER WILL NOT LATCH

- Make sure the side rails are spaced properly per step 8.
- Make sure the rails are spaced evenly, front to back.
- The latches need to move up and down freely. Lubricate if needed.

VINYL FABRIC HAS SHIFTED TOO FAR TO ONE SIDE

- Unlatch the cover at the tailgate, release the hook and loop along both sides, go to the shorter side of the tarp and tug. The fabric will slide in the aluminum headers. Pull on the shorter side until the tarp appears centered on the whole system. Latch the cover and secure the hook and loop down both sides. Repeat if more adjustment is needed.

COVER CARE AND MAINTENANCE

- Clean with mild automotive soap and water. A soft bristle brush may be used. Do not use vinyl conditioners because they will shrink the vinyl. The cover can be cleaned in a car wash.
- It is recommended that you periodically check that the cover is securely attached to your truck bed. Inspect the clamps and front corners to ensure they were properly installed and have not come loose during operation.
- It is recommended that you periodically inspect and service the rear latch closure. Clean away any excess dirt or grime.
- Covers that are used frequently or are subject to vibrations and impacts from rough roadways may require adjustment.

FAQ

WHY IS MY COVER HOLDING WATER AFTER IT RAINS?

Water pooling on the cover is normal because our cross bows are not arched. Since they are designed to sit flat some water may accumulate on the top of the cover. Once you drive your truck, the water will shed from the cover. Make sure to retighten the hook and loop fasteners along the length of the bed.

LIMITED FIVE-YEAR WARRANTY

WARRANTY COVERAGE

This truck bed cover is warranted against defects in materials or workmanship as follows. This warranty is void if the product has been damaged in an accident, or due to neglect, unforeseeable use, improper installation, improper servicing, or other cause not arising out of defects in material or workmanship.

LIMITED FIVE-YEAR WARRANTY ON HARD PARTS

All hardware included with your truck bed cover, including rails, clamps and bows carry a limited warranty for five (5) years from the original date of purchase, subject to the terms below.

LIMITED FIVE-YEAR WARRANTY FOR FABRIC

The fabric on your truck bed cover carries a limited warranty for five (5) years from the original date of purchase, subject to the terms below.

WARRANTY IS NOT TRANSFERABLE

The warranty is to the initial owner purchasing the truck bed cover and it is not transferrable to a subsequent end user. Proof of purchase may be required to enforce these warranty rights.

WARRANTY CONDITIONS

Failure to follow these warnings and care instructions will void the warranty:

- Clean with mild automotive soap and water only.
- Do not use conditioners that contain silicone or petroleum.
- The tonneau cover must be secured at all points when the vehicle is in motion. When not fully closed with the rear latch engaged the cover must be completely rolled up and secured at the cab with both provided retainer straps attached. Do NOT drive with the bed cover in a partially open position.
- Cargo should not contact the tarp at any point. Protrusions in the tarp will stress the vinyl fabric. Cargo may also shift while traveling causing it to press against the vinyl fabric and damage it.
- Do NOT tie cargo to truck bed cover framework.
- Check rail clamps for tightness after a week of driving following the installation of the cover and periodically thereafter.
- Do NOT roll the cover into the rear cab window. Do NOT stow the cover against the cab of the truck.
- If the cover is going to be rolled open for an extended amount of time, periodically re-roll the cover and secure the retainer straps to ensure the cover doesn't rest against the cab of the truck.
- Before opening, the cover must be free of all foreign materials including snow and ice.
- Do NOT tow your vehicle from the rear with the cover on your vehicle. If towing from the rear is required, the cover MUST be removed from the vehicle and properly stored.

WARRANTY PERFORMANCE

If all warranty conditions are met, a defective truck bed cover, tarp, or hardware component will either be repaired or replaced (at our option). We reserve the right, for any warranty, to substitute a newer model of bed cover having similar form and function, to offer a warranty discount on an entire replacement system, and/or provide remedies other than those mentioned in this document.

WARRANTY PROCESS

A Return Material Authorization number must be obtained from our Customer Service Department prior to returning any product. We may require the original item to be returned postage prepaid for final determination. Shipping charges will apply for any repair or replacement. Other than postage or shipping charges, no charge will be made for repair or replacement under this warranty.

This warranty gives you specific legal rights. As an owner, you may also have additional rights and remedies under the laws of your state.

WARRANTY REGISTRATION

Warranty registration must be on file and/or proof of original purchase (detailed and dated receipt) required for warranty to be effective.

Register online at <https://realtruck.com/truxedo-warranty/>

**REGISTER
YOUR
WARRANTY
ONLINE**



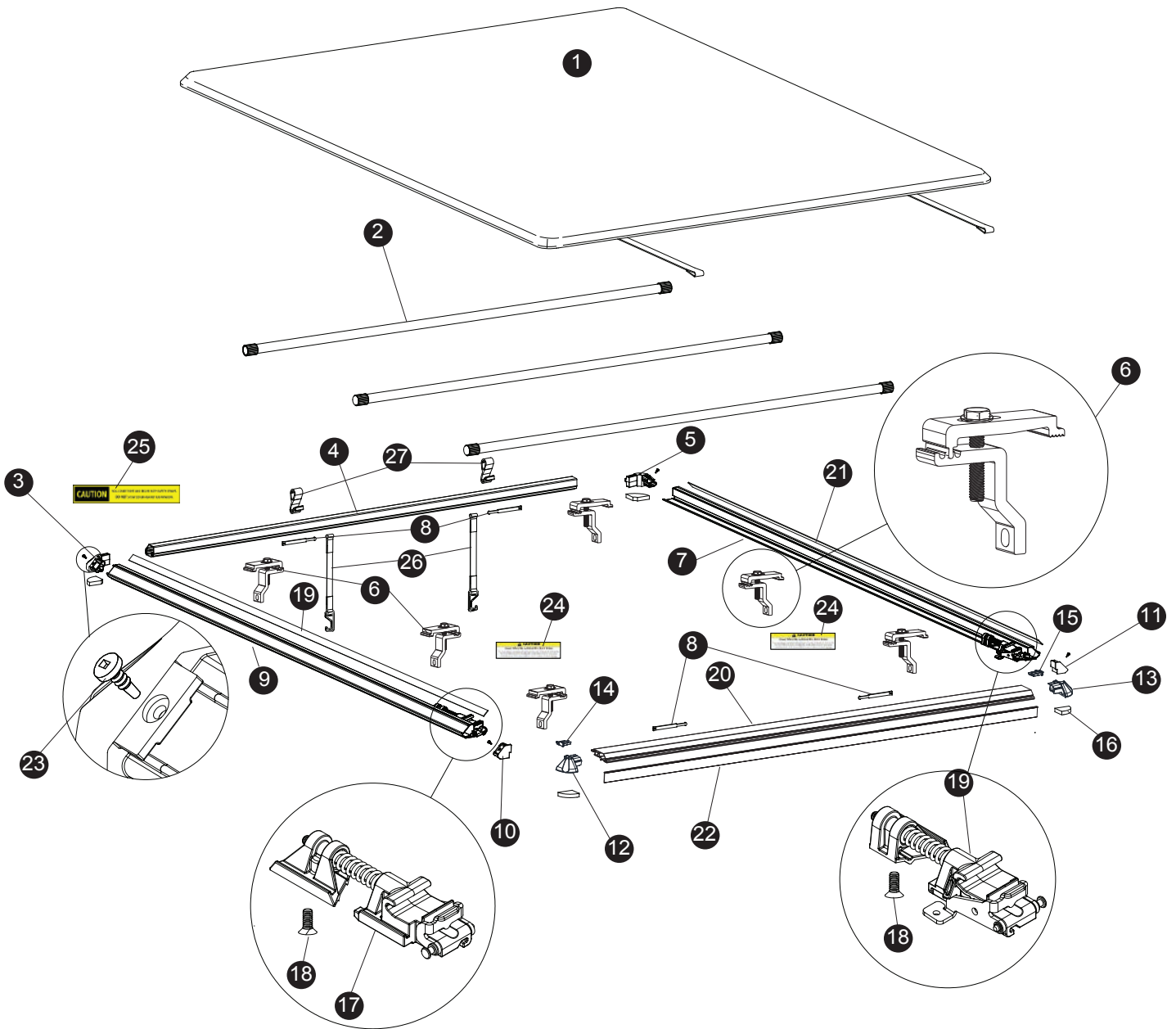

TRUXPORT REPLACEMENT PARTS

1	*	Cover (Vinyl Only)	15	1704537	Small Rear Header End Plug Pass.
2	*	Bow	16	1703568	Four Corners Weather Seal
3	1705421	Corner Plug	17	1117868	Complete Latch Assy, Driver's Side
4	*	Cab End Header	18	1703560	Flat Head Cap Screw
5	1705420	Corner Plug	19	1117869	Complete Latch Assy, Passenger's Side
6	1707126	Clamp Assembly (6)	20	*	Tailgate Header
7	*	Passenger's Side Rail	21	*	Hook Fastener
8	1116028	Retainer Clips	22	*	Rear Header Seal
9	*	Driver's Side Rail	23	1705629	Self-Drilling Screw, Square Head 6-20 X 3/8"
10	1705422	End Plug Driver's Side	24	1703750	Decal Dual Latch
11	1705423	End Plug Pass. Side	25	1705142	Decal Do Stow Cover Against Cab Window
12	1704534	Large Rear Header End Plug Driver's	26	*	Retainer Strap
13	1704535	Large Rear Header End Plug Pass.	27	1706209	Retainer Loop
14	1704536	Small Rear Header End Plug Driver's			

* Please specify length or make and model of vehicle.