



INSTALLATION INSTRUCTIONS

YAMAHA ATV PLOW

Mount Kit: 39553
Application: '99+ GRIZZLY

Your safety, and the safety of others, is very important. To help you make informed decisions about safety, we have provided installation and operating instructions and other information on labels and in this guide. This information alerts you to potential hazards that could hurt you or others. It is not possible to warn you about all potential hazards associated with this product, you must use your own good judgment.

CARELESS INSTALLATION AND OPERATION CAN RESULT IN SERIOUS INJURY OR EQUIPMENT DAMAGE. READ AND UNDERSTAND ALL SAFETY PRECAUTIONS AND OPERATING INSTRUCTIONS BEFORE INSTALLING AND OPERATING THIS PRODUCT.

This guide identifies potential hazards and has important safety messages that help you and others avoid personal injury or death. **WARNING** and **CAUTION** are signal words that identify the level of hazard. These signal words mean:

▲ WARNING signals a hazard that could cause serious injury or death, if you do not follow recommendations.

CAUTION signals a hazard that may cause minor to moderate injury, if you do not follow recommendations.

This guide uses **NOTICE** to call attention to important mechanical information, and **Note**: to emphasize general information worthy of special attention.

▲WARNING

SEVERE INJURY OR DEATH MAY RESULT IF YOU IGNORE ANY OF THE FOLLOWING.

- **Read the Plow Operator's Manual, the Winch Operator's Manual, and all warning labels before operating.**
- **Operate ATV at a walking speed with the blade installed. Do Not exceed 5mph (8 km/h) even with the blade up.**
- **Plow Cautiously, impact with a hidden or stationary object may cause the ATV to stop suddenly or go out of control.**
- **Do Not operate the ATV on slopes greater than 10° with the plow installed.**
- **Do Not stand or ride on the plow.**
- **Stay clear of moving parts and joints. Keep others away when operating or adjusting plow.**
- **Inspect the plow mechanism, fasteners, cable, and adjustments before operating. Replace all worn or damaged parts before operating.**
- **Lower the plow to the down position before leaving the ATV unattended.**

TOOLS REQUIRED:

Ratchet
Sockets: 7/16, 9/16"
14mm, 17mm
Wrench: 7/16, 9/16"
Phillips Screwdriver (optional)

PARTS LIST:

<u>PART NO.</u>	<u>QUANTITY</u>	<u>DESCRIPTION</u>
1827	1	3/8" x 1" Hex Bolt
6725	6	1/4" Nylock Nut
6779	1	3/8" dia nylock nut
7482	4	Washer, Lock, 10mm
13253	4	1/4-20 x 1 1/4" Hex Bolt
22528	4	M10-1.25 x 30mm Hex Bolt
31806	4	Spacer, Aluminum, Small
35391	2	J-Bolt
39532	1	Frame Mount, Right
39531	1	Frame Mount, Left
39530	2	Frame Mount, Inner
62845	1	J-Bolt Mounting Bracket

1. Frame Mount Installation:

Assemble the frame brackets as shown in Figure 2. The small part of the frame bracket must be fastened to the inside of the frame bracket as shown to work properly.

NOTE: Right and left frame brackets are different and must be installed on the correct side.

Remove the bolts that secure the front of the floor board to the frame. Longer fasteners have been provided in this kit to replace the factory bolts.

Secure the frame brackets to the frame with fasteners supplied. Be sure to use lock washers under the heads of the bolts and check these periodically to make sure they have not come loose.

Torque fasteners to following specifications:

Torque 10mm Bolts: 35ft. lb. (48 N m)

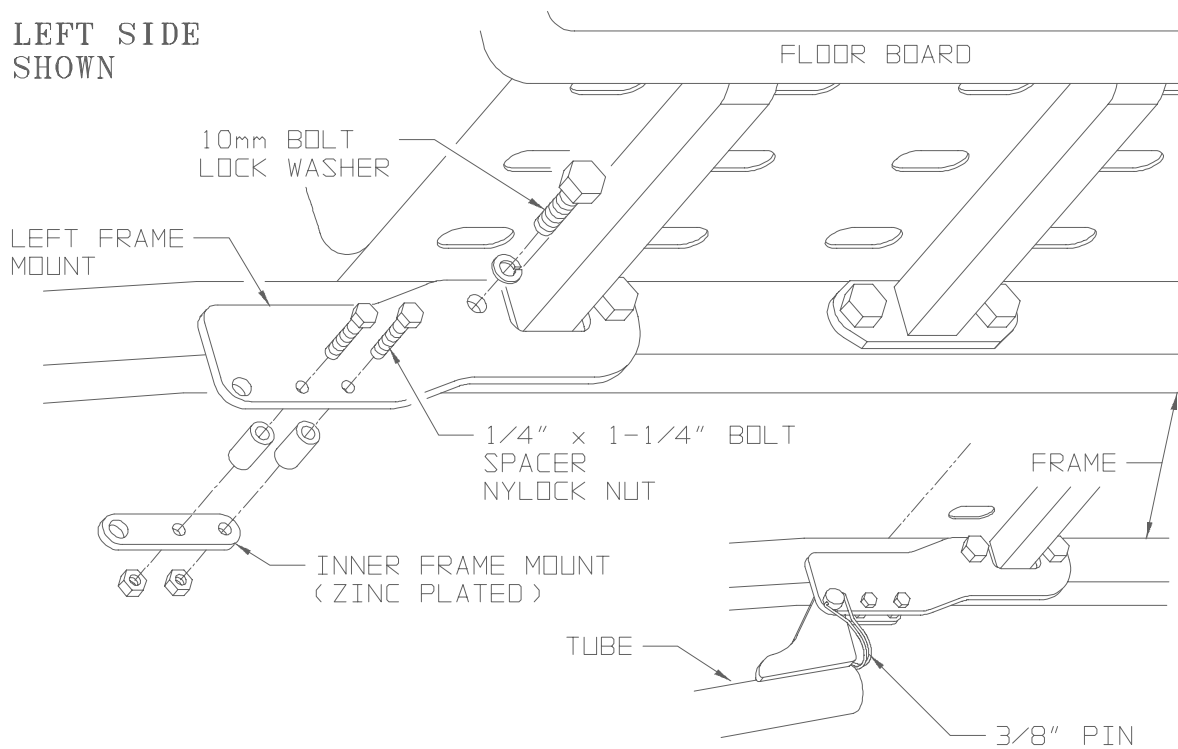

FIGURE 2: FRAME MOUNT INSTALLATION

2. Plow Installation:

Slide the plow into position with the tubes under the ATV. Lift the end of the tube assembly into position so the holes in the Tube Wings line up with the 3/8" holes in the frame brackets (Figure 2). A Phillips head screwdriver may be used to align the holes.

Insert both 3/8" pins and hook the retaining clips on the ends of the pins to secure the plow to the ATV.

⚠CAUTION

When using a winch with this plow, read your winch operator manual before proceeding with this installation. A roller fairlead must be used for lifting and lowering the plow. Cable damage will occur if a roller fairlead is not used.

Attach the J-bolt bracket to the center hole in the plow cross member using a 3/8" dia x 1" long bolt as shown in figure 3. The bracket should be mounted on the blade side of the crossmember with the side flanges parallel to the ground. Terminate the with a 3/8" dia nylock nut. Tighten the bolt and nut to recommended torque of 20 ft-lb (28 N-m).

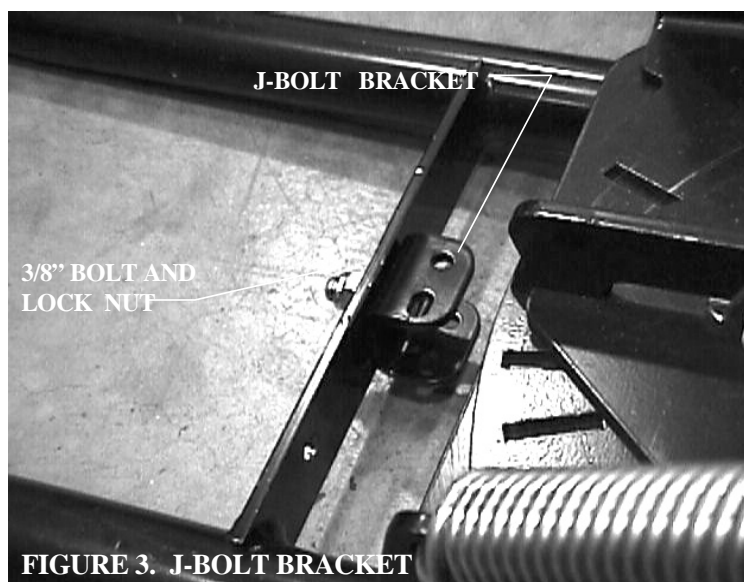

FIGURE 3. J-BOLT BRACKET

Run the winch cable over the roller fairlead and down to the J-bolt bracket. Using a 1/4" dia J-bolt, hook the loop on the end of the winch cable and slide the threaded end of the J-bolt into the slotted hole in the J-bracket. Terminate the end of the J-bolt with a 1/4" dia nylock nut. Tighten the nut until the winch cable is snug inside the J-bolt as shown in figure 4.

Note: Do not remove the winch hook installed on the end of the winch cable, simply slide it out of the way.

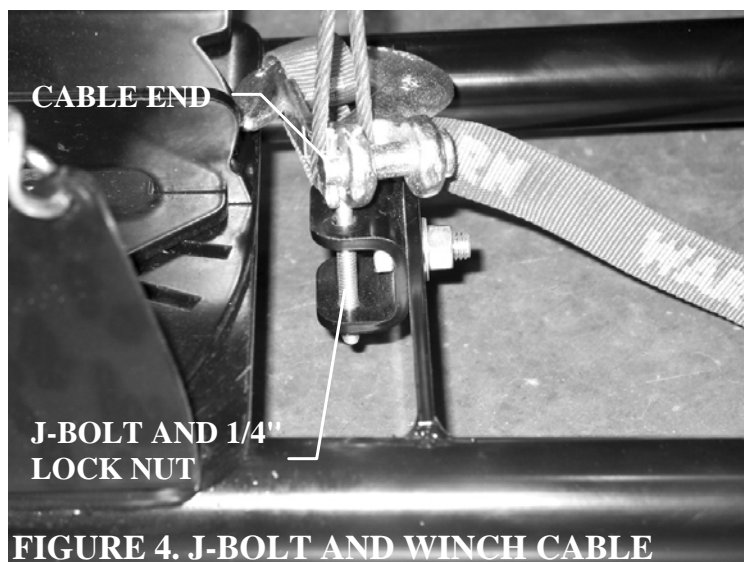

FIGURE 4. J-BOLT AND WINCH CABLE

⚠ CAUTION

The purpose of the J-bolt is to break the connection between the plow and ATV when the plow is subjected to high forces that could damage the plow or vehicle. The plow will drop instantly if the J-bolt breaks, so be sure there are no bystanders when operating the plow.

Instances when the J-bolt might break are:

- . If the plow is raised too high and stalls.
- . If the operator is trying to lift too much material with the plow blade.

In general, do not raise the top of the plow blade above the headlights of the vehicle. If the plow stalls, stop the winch immediately and lower the plow. After pushing material with the plow, backup the ATV prior to raising it. If the J-bolt breaks, replace it with the spare hardware found in this kit. Read the Plow Operators Guide for more information.

The installation should now be complete.
Be sure to read the operator manual prior to use of this product.