



SIGNATURE OF QUALITY

AUTOMOTIVE PRODUCTS, INC.

# INSTALLATION INSTRUCTIONS

APPLICATION: 2015 CHEVROLET SUBURBAN/TAHOE  
POLICE PUSH BUMPER ELITE XD: 36-53805

ITEM	QUANTITY	DESCRIPTION	TOOLS NEEDED
1	1	POLICE PUSH BAR ASSEMBLY	RATCHET
2, 3	2	UPPER MOUNTING BRACKET DRIVER/PASSENGER	TORQUE WRENCH
4, 5	2	BOTTOM MOUNTING BRACKET DRIVER/PASSENGER	ALLEN SOCKET
6	6	M12 x 30mm HEX HEAD FLANGE BOLT (Yellow Zinc)	2" HOLE SAW
7	6	M12 SERRATED FLANGE NUT (Yellow Zinc)	15MM SOCKET
8	2	M10 X 35mm SOCKET HEAD CAP SCREW (Yellow Zinc)	16MM SOCKET
9	2	M10 CUPPED WASHER (Yellow Zinc)	18MM SOCKET
10	2	M12 x 35mm HEX SOCKET BUTTON HEAD SCREW (Black Plated S/S)	SOCKET EXTENSION
11	6	M12 CUPPED WASHER (Black Plated Stainless)	18MM WRENCH
12	6	M12 SERRATED FLANGE NUT (Black Plated Stainless)	PUNCH
13	4	M12 x 40mm HEX SOCKET BUTTON HEAD SCREW (Black Plated S/S)	DRILL MOTOR

## ANTI-SEIZE LUBRICANT MUST BE USED ON ALL STAINLESS STEEL FASTENERS TO PREVENT THREAD DAMAGE AND GALLING

1. Remove contents from box, verify if all parts listed are present and free from damage. Carefully read and understand all instructions before attempting installation. Note: This product may be mounted stand-alone or in conjunction with Winch Tray P/N 46-23805 (sold separately).

### STEP 1: Removal and Trimming

- Locate the two rectangular covers on the bumper insert. These rectangular covers will need to be removed. Trimming may be required (Figure 1). Note: Some models may have factory tow hooks installed, if so, the tow hooks will have to be removed and trimming is required.

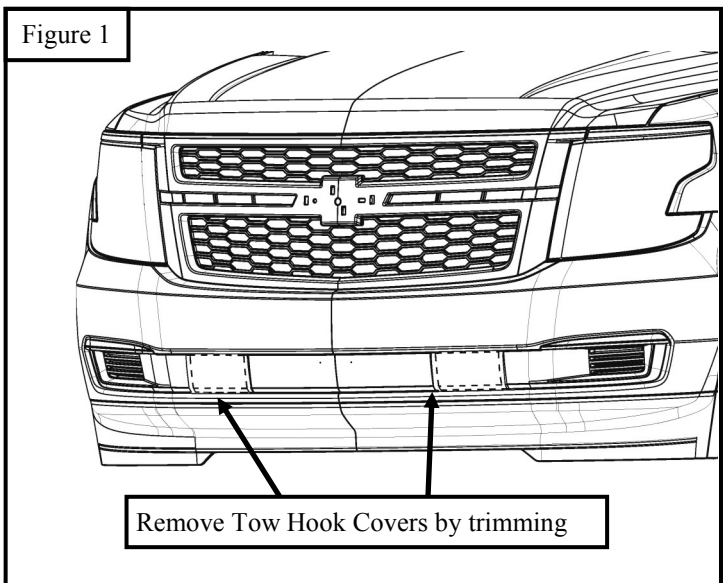

Figure 1

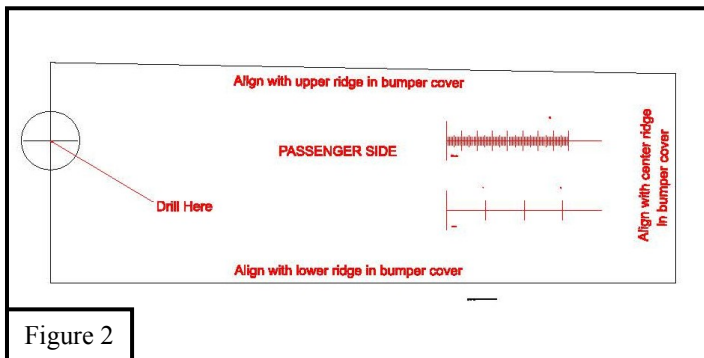
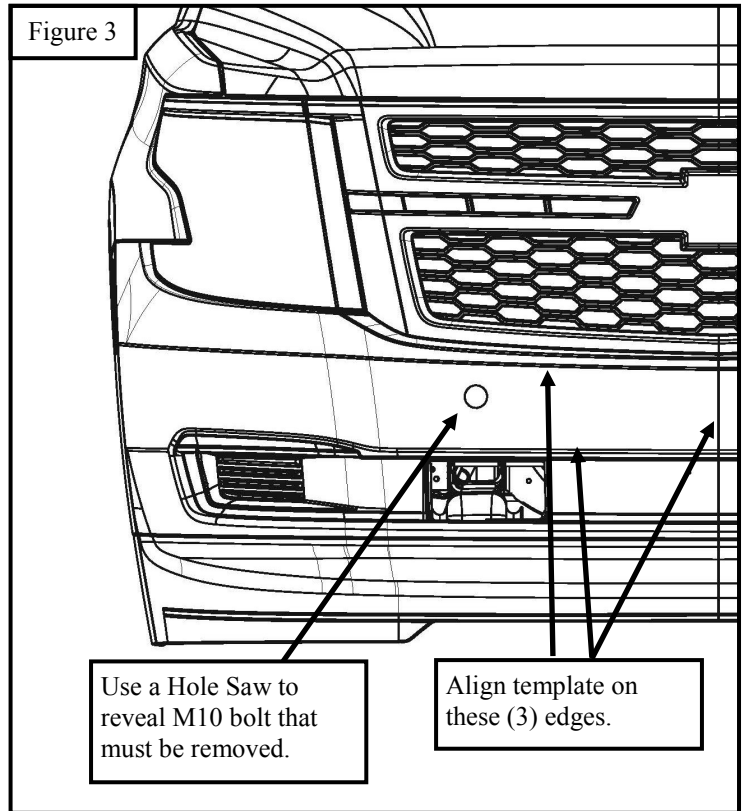
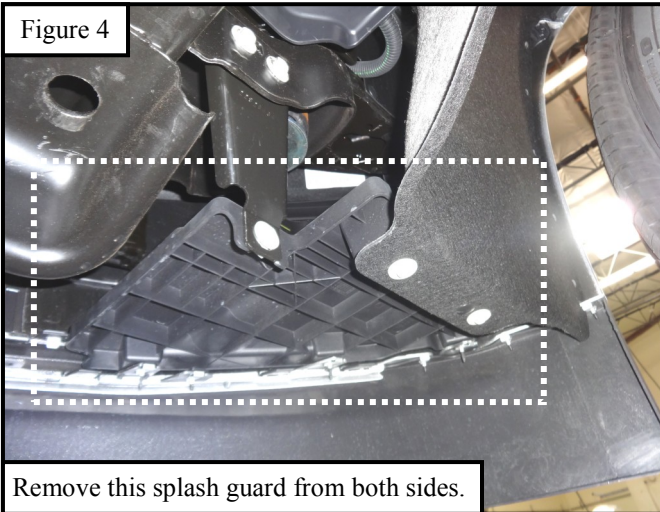

Figure 2

- Locate the Template (Figure 2) and place it on the bumper between the bumper insert and below the grille (Figure 3). Use a punch to mark the center of the circle on the template then cut a 2" hole using a hole saw.
- After drilling, locate through the hole an M10 factory bolt that must be removed (Figure 3).



**Step 2: Installing Bottom Brackets** - NOTE: (Skip this step if mounting the Push Bumper in conjunction with 46-23805 Winch Tray Kit)

- Locate the Passenger and Driver side Bottom Brackets (items 4 & 5 on Figure 5), and position each one where the rectangular piece is trimmed from the vehicle's bumper cover (Figure 6).

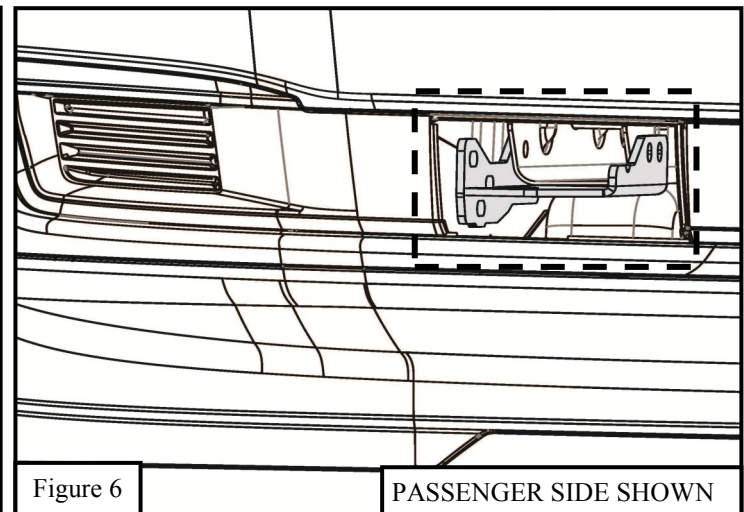
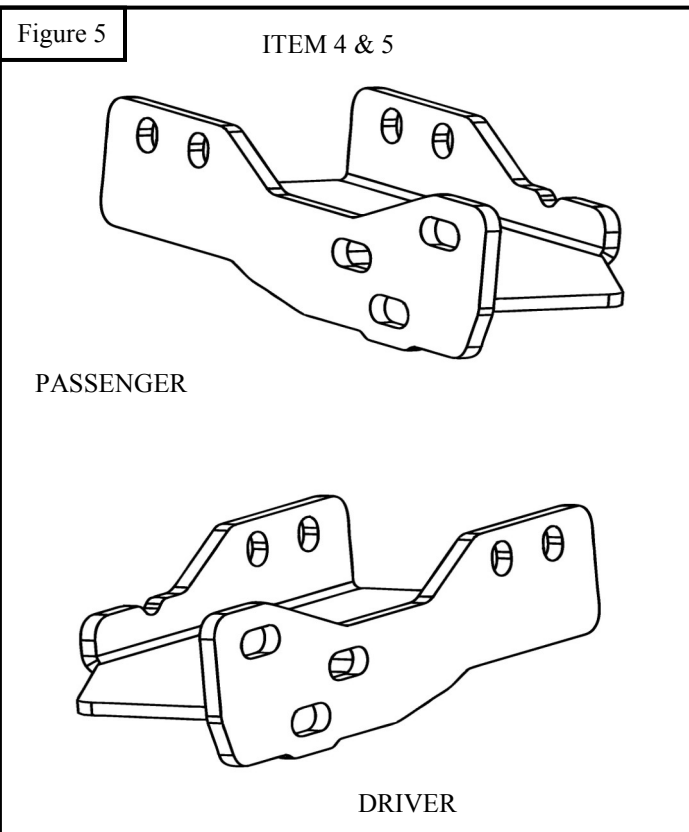

Westin Automotive Products, Inc.  
320 Covina Blvd  
San Dimas, Ca. 91773

- Loosely attach the Bottom Bracket to the frame using (3) M12 Hex Head Flange Bolts (item 6) and (3) M12 Serrated Flange Nuts (item 7). Refer to Figure 7.

**Step 3: Installing Upper Brackets**

- Locate the Upper Mounting Brackets (items 2 & 3 on Figure 8) and attach them to the frame where the circular 2” hole was made using the template (Figure 9).
- Loosely attach the Upper Mounting Brackets by using (2) M10 Socket Head Cap Screws (item 8) and (2) M10 Cupped Washers (item 9). Refer to Figure 10.

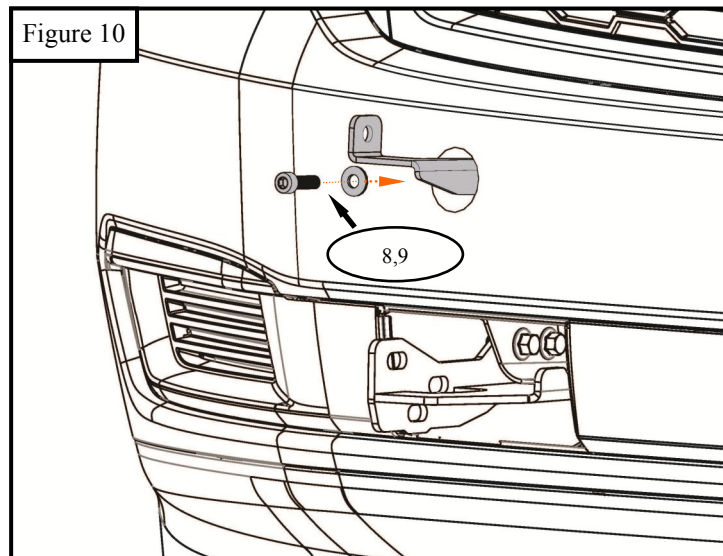
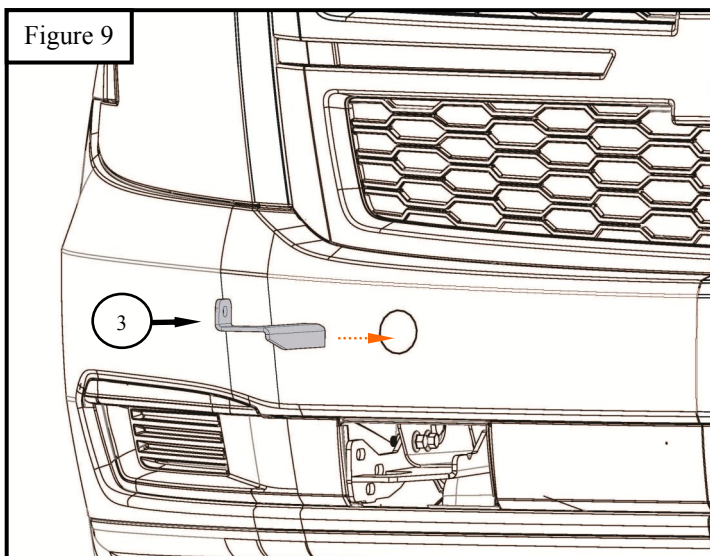
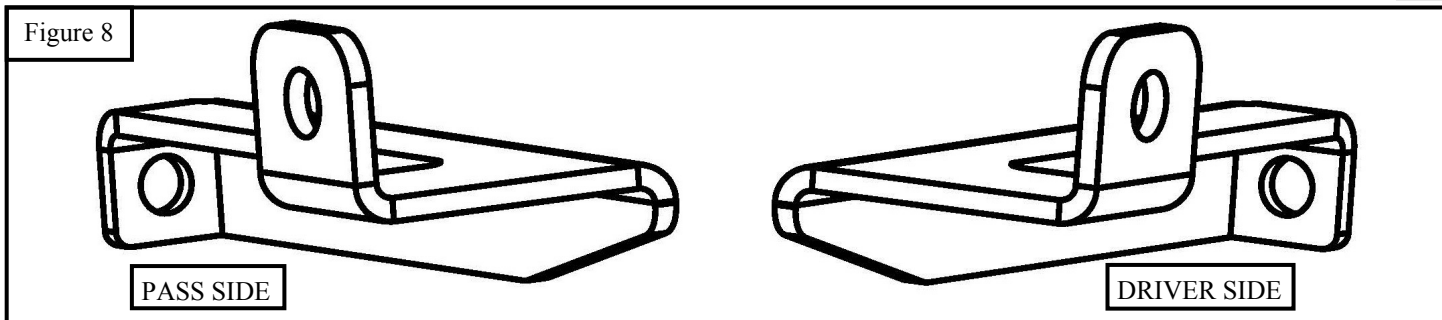
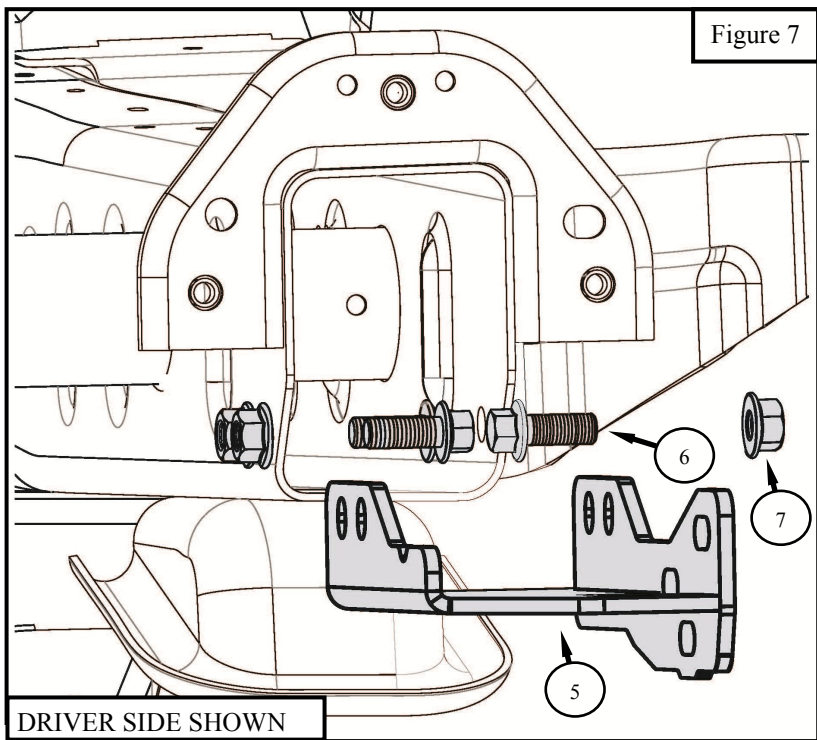



## STEP 4: Installing the Push Bumper

- Attach the Push Bumper to the Bottom Brackets using (4) M12 X 40 Hex Socket Button Head Screws (item 13), (4) M12 Cupped Washers (item 11) and (4) M12 Serrated Flange Nuts (item 12). Refer to Figure 11.
- If using the Push Bumper in conjunction with the 46-23805 Winch Tray Kit (sold separately) attach the Push Bumper to the Winch Tray and Winch Tray Mounting Bracket using (4) M12 X 40 Hex Socket Button Head Screws (item 13), (4) M12 Cupped Washers (item 11) and (4) M12 Serrated Flange Nuts (item 12). Two Spacers (included with the 46-23805) need to be positioned, one per side, between the Winch Tray Mounting Bracket and the Push Bumper. Refer to Figure 12.
- Attach the Push Bumper to the Upper Brackets using (2) M12 X 35 Hex Socket Button Head Screws (item 10), (2) M12 Cupped Washers (item 11) and (2) M12 Serrated Flange Nuts (item 12). Refer to Figures 11 & 12.
- Align and adjust the Push Bar then tighten and torque all M10 hardware to 30-35 ft-lbs./all M12 to 50-55 ft-lbs.

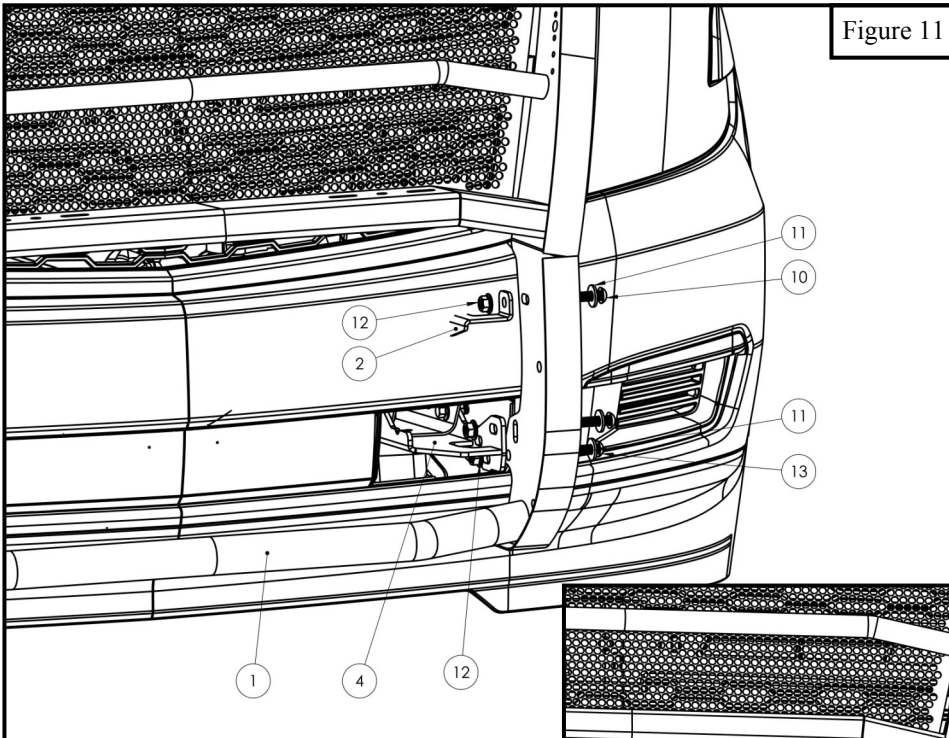

Figure 11

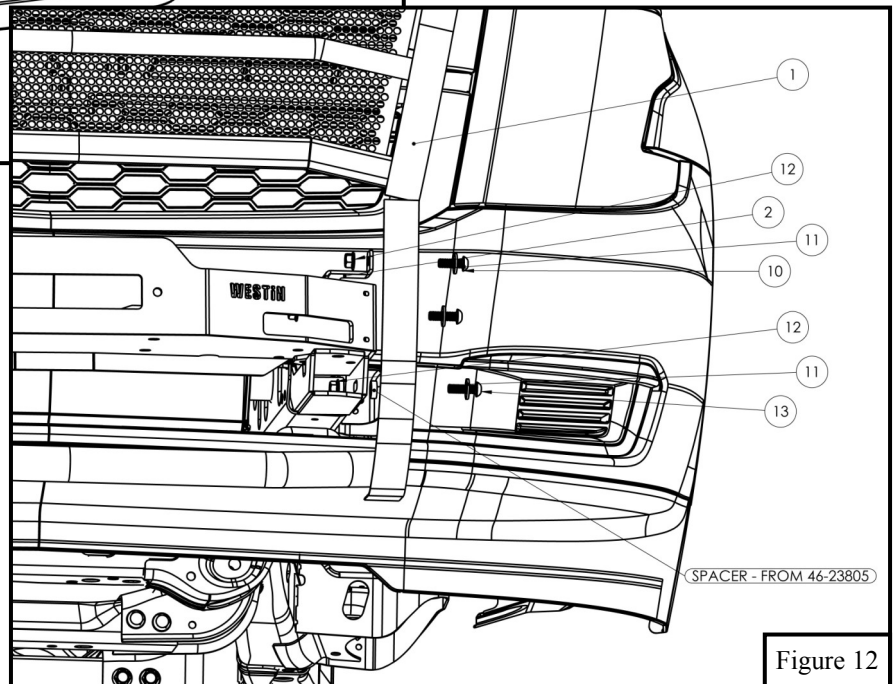

Figure 12



Westin Automotive Products, Inc.  
320 Covina Blvd  
San Dimas, Ca. 91773

Thank You for choosing Westin products  
For Additional installation assistance please call  
Customer service (800) 793-7846  
www.westinautomotive.com



**PUSH BAR INSTALLATION COMPLETE**



**PUSH BAR WITH WINCH TRAY INSTALLATION COMPLETE**

#### CARE INSTRUCTIONS

- REGULAR WAXING IS RECOMMENDED. DO NOT USE ANY TYPE OF POLISH OR WAX THAT MAY CONTAIN ABRASIVES.
- STAINLESS STEEL PRODUCTS CAN BE CLEANED WITH MILD SOAP AND WATER. STAINLESS STEEL POLISH SHOULD BE USED TO POLISH SMALL SCRATCHES.
- GLOSS BLACK FINISHES SHOULD BE CLEANED WITH MILD SOAP AND WATER.



Westin Automotive Products, Inc.  
320 Covina Blvd  
San Dimas, Ca. 91773

Thank You for choosing Westin products  
For Additional installation assistance please call  
Customer service (800) 793-7846  
[www.westinautomotive.com](http://www.westinautomotive.com)