



## INSTALLATION INSTRUCTIONS

### PRO-E ELECTRIC RUNNING BOARDS

APPLICATION:  
Jeep Wrangler JK Unlimited 4-door 2007-2018

PART NUMBER:  
29-23295



Estimated Time to Complete Product Installation: 3 - 4 Hours

# CONTENTS

Component List	Page 2
Mechanical Component Installation Procedure	Page 5
Electrical Component Installation Procedure	Page 10
Product Warranty and Warnings	Page 18

## COMPONENT LIST

ITEM	QUANTITY	DESCRIPTION	TOOLS NEEDED
1	2	RUNNING BOARD ASSEMBLY	5mm ALLEN WRENCH
2	1	DRIVER SIDE FRONT MOTOR LINKAGE	
3	1	PASSENGER SIDE FRONT MOTOR LINKAGE	13mm SOCKET
4	1	DRIVER SIDE REAR MOTOR LINKAGE	18 mm SOCKET
5	1	PASSENGER SIDE REAR MOTOR LINKAGE	WIRE STRIPPER
6	1	CONTROL MODULE ASSEMBLY	ELECTRICAL TAPE
7	2	FUSE	RATCHET
8	1	POWER BOARD MANUAL SWITCH	TORQUE WRENCH
9	2	MAGNETIC INDUCTION MODULE	13 mm Wrench
10	4	DOOR MAGNET	18mm Wrench
11	4	LED LIGHTS	
12	1	WIRING HARNESS	
13	25	ZIP TIES	
14	1	DRIVER MOTOR PROTECTIVE BRACKET	
15	1	PASSENGER MOTOR PROTECTIVE BRACKET	
16	2	REAR MOUNTING PLATE	
17	2	M12 TENSION BLOCK	
18	2	M8 x 25 mm STUD BOLT A	
19	2	12mm SPRING WASHER	
20	2	12mm FLAT WASHER	
21	2	8mm FLAT WASHER	
22	16	8mm SPRING WASHER	
23	14	8mm FLAT WASHER	
24	10	M8 x 20mm HEX HEAD BOLT	
25	2	M8 x 25mm HEX HEAD BOLT	
26	4	M8 x 35mm HEX HEAD BOLT	
27	2	M12 x 35mm HEX HEAD BOLT	
28	8	M6 HEX SOCKET CAP SCREW	

# PRODUCT PACKING LIST

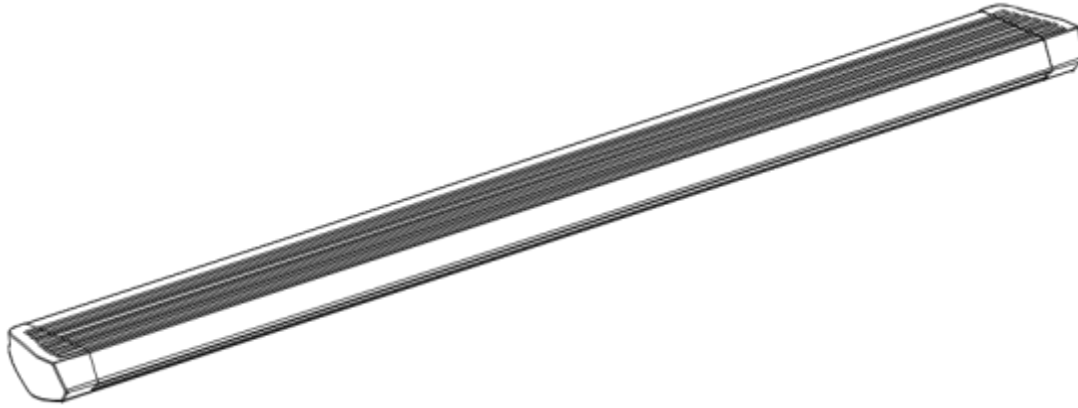

ITEM 1



ITEM 2



ITEM 3

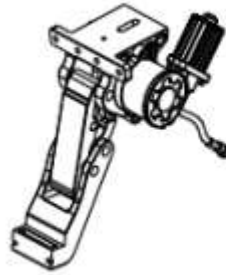

ITEM 4

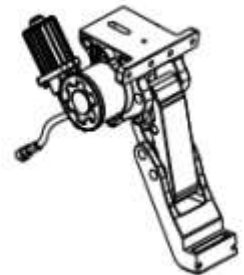

ITEM 5



ITEM 14

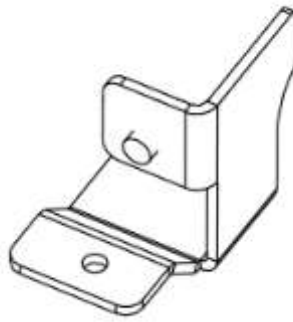

ITEM 15

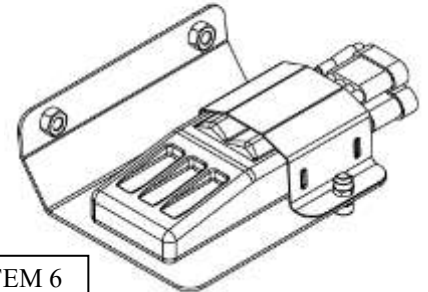

ITEM 6



ITEM 7



ITEM 13

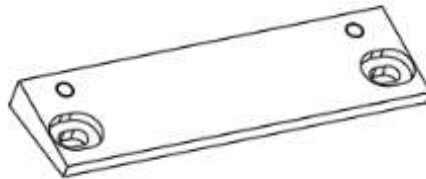

ITEM 16

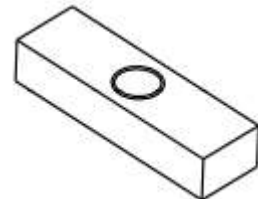

ITEM 17



Westin Automotive Products, Inc.  
320 W. Covina Blvd  
San Dimas, Ca. 91773

Thank you for choosing Westin products  
for additional installation assistance please call  
Customer Service (800) 793-7846  
www.westinautomotive.com

DATE: 4/1/2024

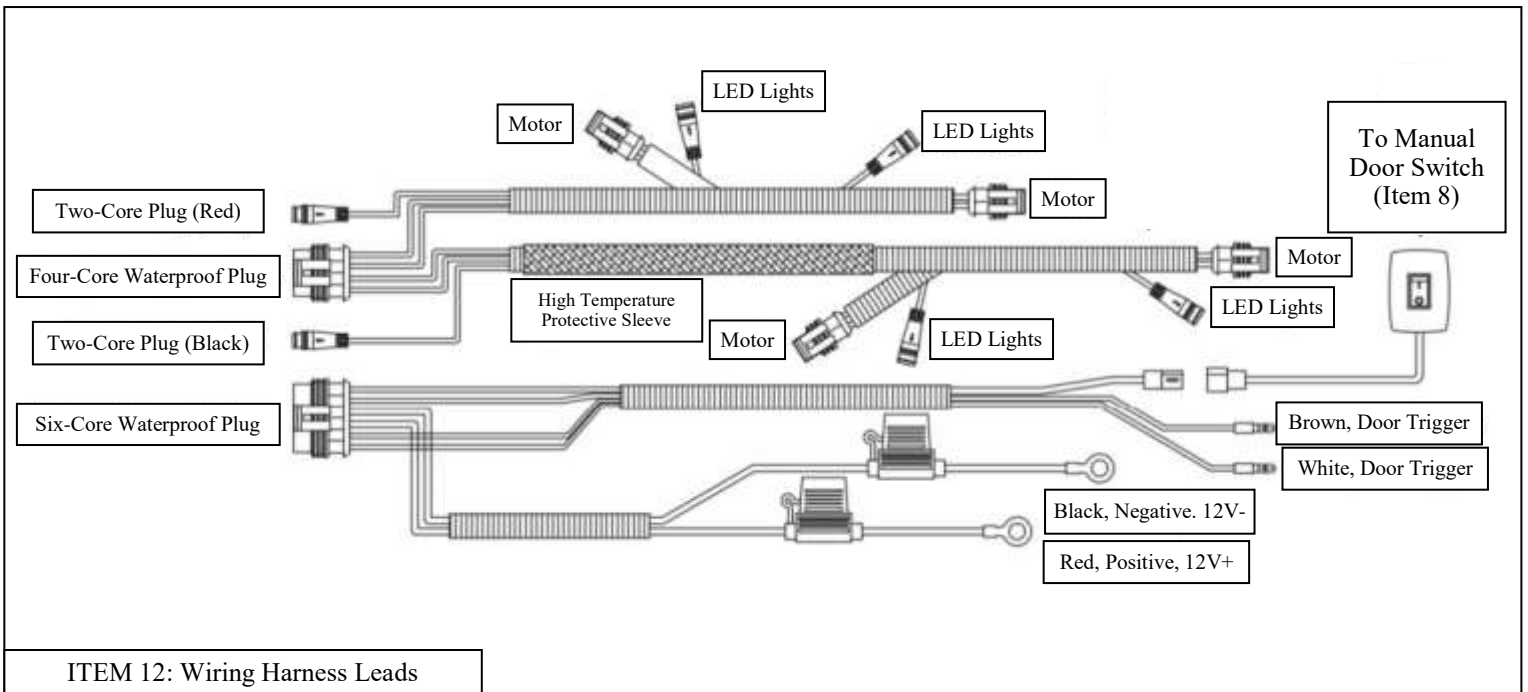
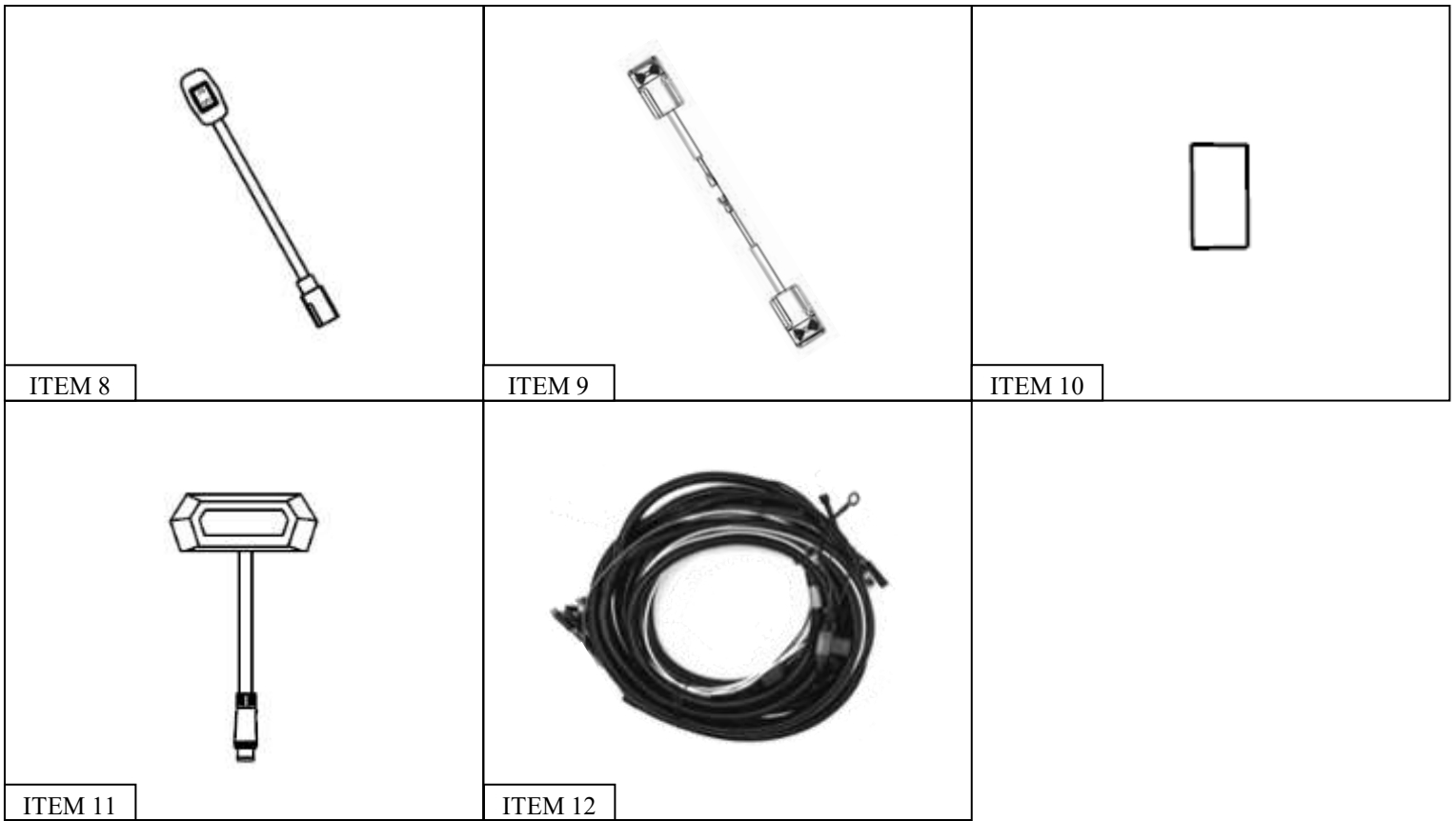

Remove the components from the box, verify if all parts listed are present and free from damage.

Carefully read and understand all instructions before attempting installation.

It is recommended that anti-seize lubricant is used on all stainless steel fasteners to prevent thread damage and galling.

**Note that failure to identify damage before installation could lead to a rejection of any claim.**

# MECHANICAL COMPONENT INSTALLATION PROCEDURE

Passenger side shown

Figure 1

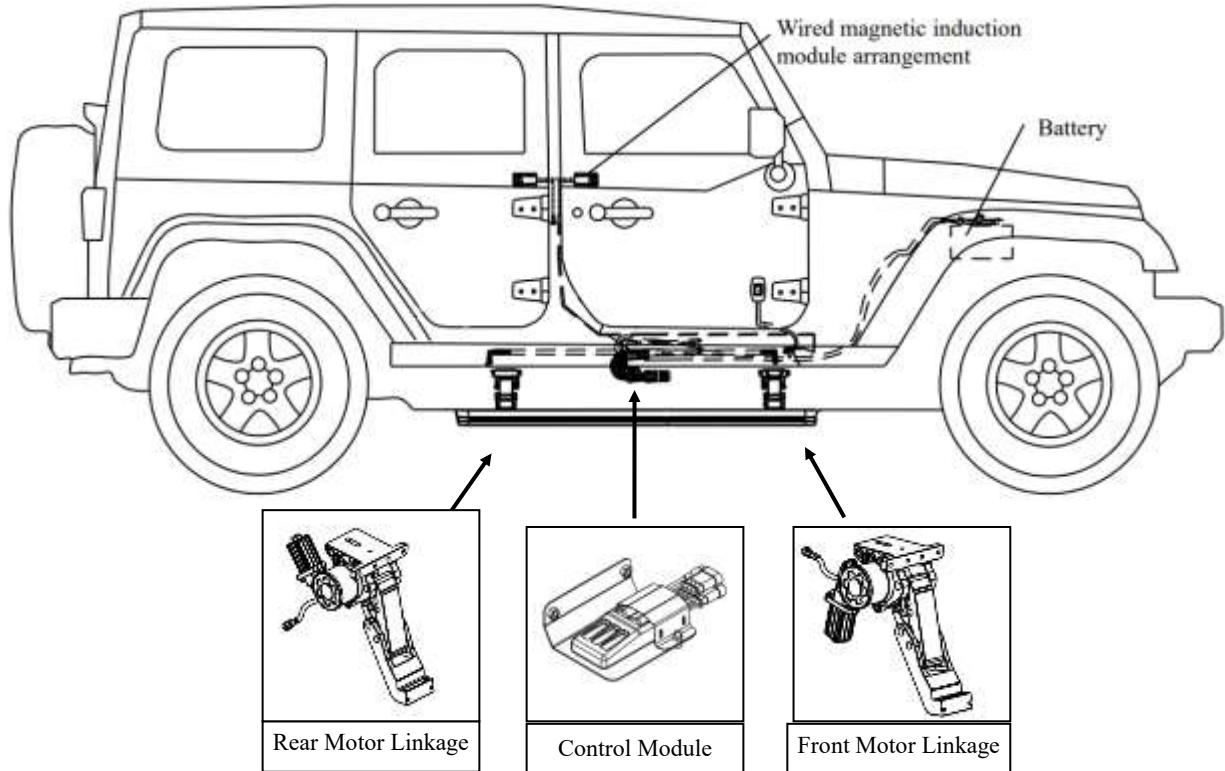

Use **Figure 1** as a guide for **Motor Linkage** and **Control Module** orientation and location. Also see how the **Wiring Harness** and **Door Magnets** will be fitted around the vehicle.

**Note:** Each motor linkage is labeled “Front Right” / “Rear Left” for ease of assembly

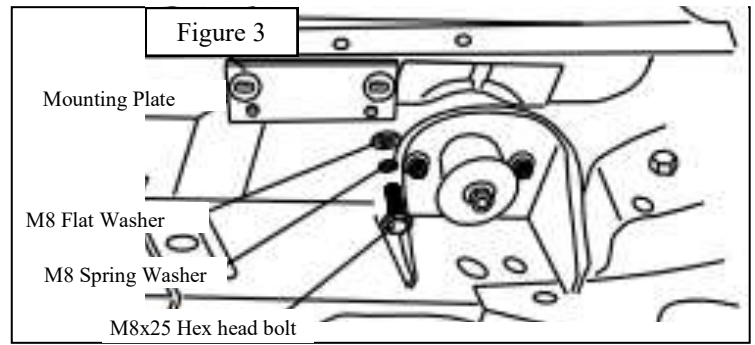
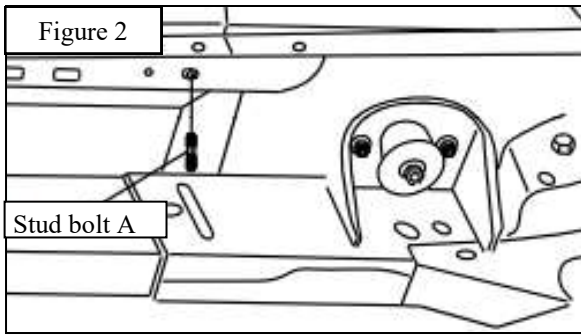

**Step 1:** First disconnect the battery. Start with the negative followed by the positive terminal.

**Step 2:** Then screw the stud bolt as indicated on **Figure 2**.

**Step 3:** Then install the mounting plate as shown in the picture using M8 hardware (items 22-24) (Tighten Torque 23Nm) .

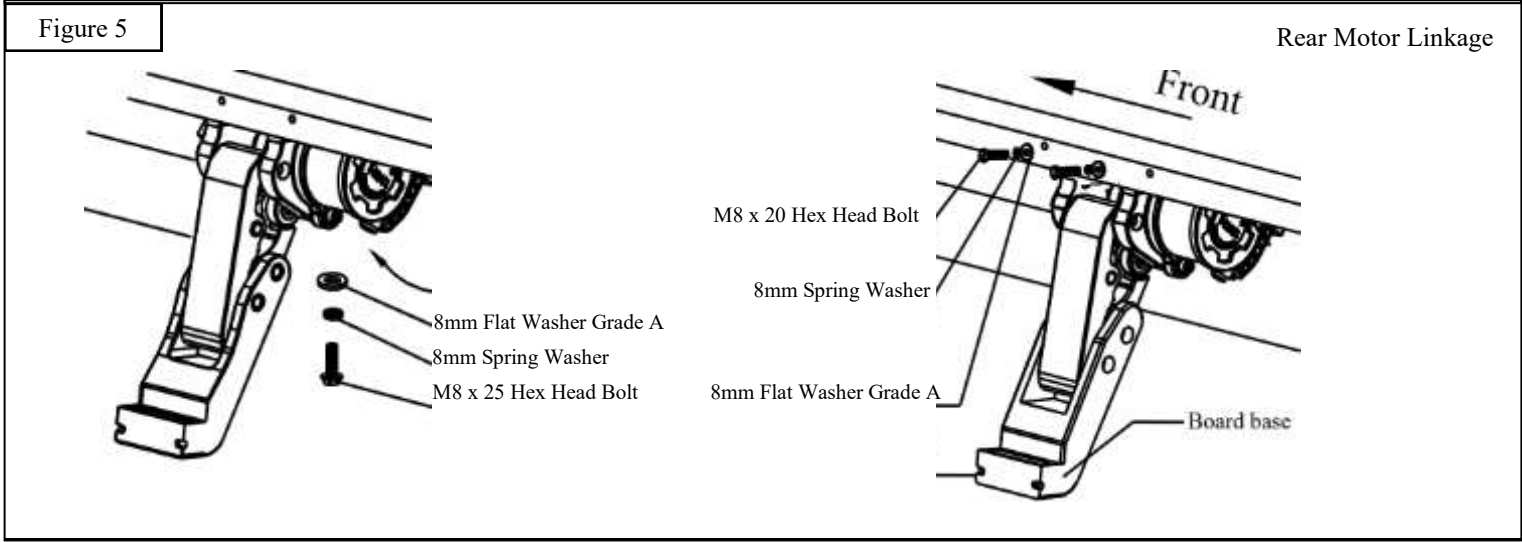
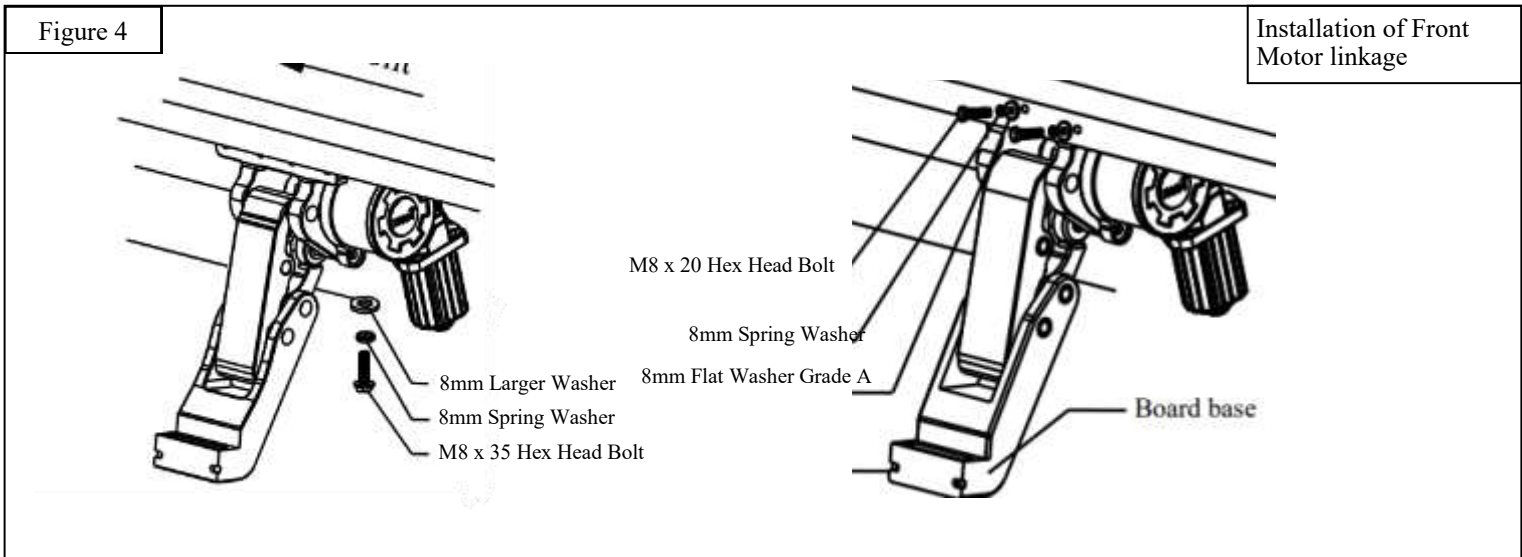

**Step 4:** On the Passenger side of the vehicle, loosely install the Front Motor Linkage (Item 2) to the front rocker panel mounting location using the supplied M8 hardware as shown in **Figure 4 & 6**. Please refer to **Figure 1 – 3** for bracket orientation and location.

**Step 5:** Loosely install the Rear Motor Linkage (Item 3) to the rear rocker panel mounting location using the supplied M8 hardware as shown in **Figure 5 & 7**.



JL installation

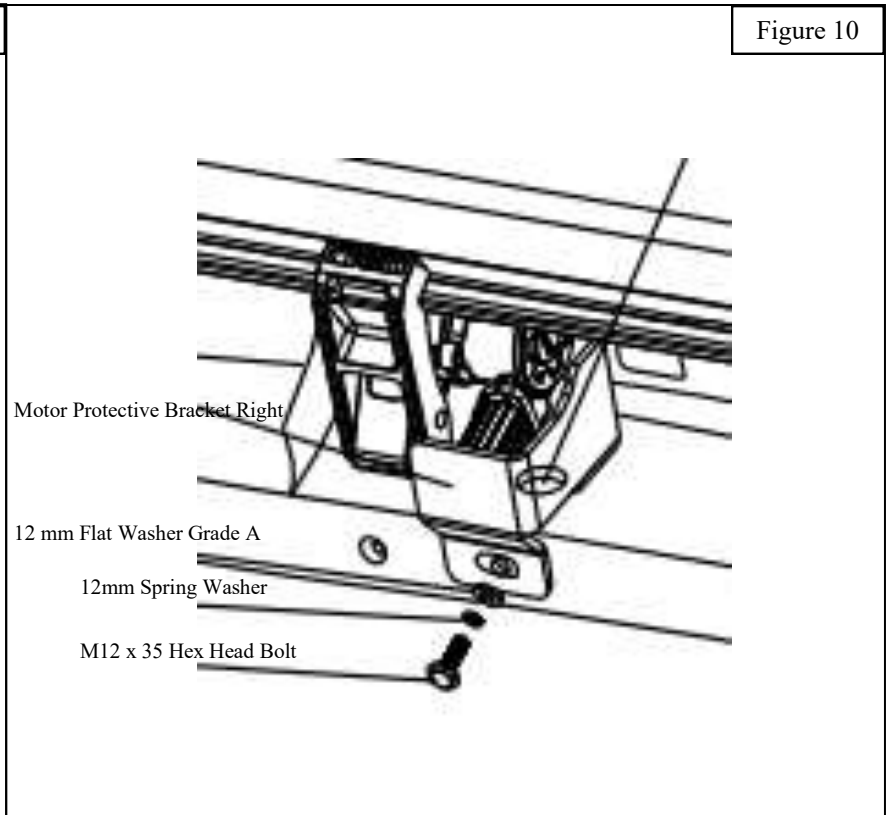
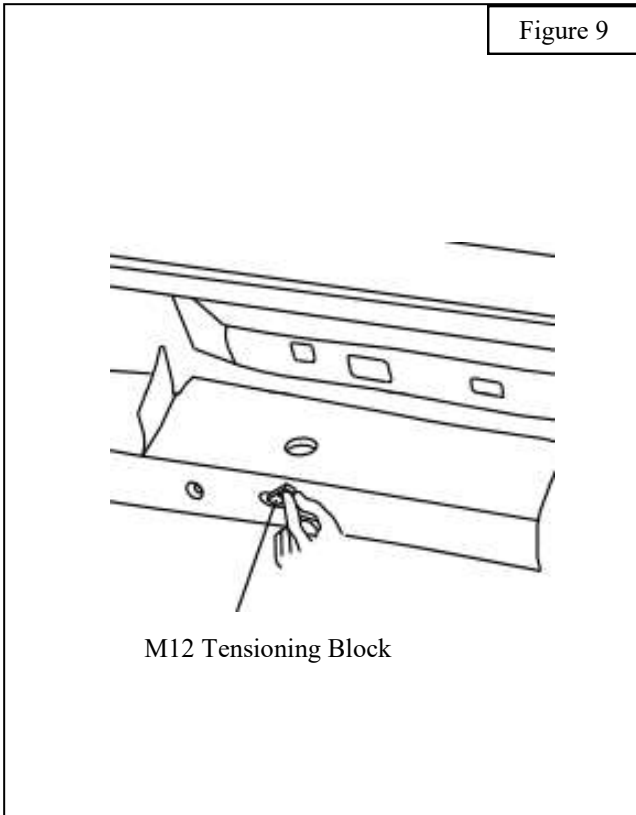

**Step 6:** Install passenger side protective motor bracket **Figure 10**.

**Step 7:** Install the passenger side running board **Figure 11**. Position the board on the front and rear motor assembly and align the sliding T-Nuts on the running board with the corresponding slots on the front and rear motor bases.

**Step 8:** Once the T-Nuts are aligned, slightly rotate the running board to allow the T-Nuts to set into the slots on the front and rear motor bases. Loosely secure the running board to the front and back bases using the M6 x 25 socket head cap screws.

Figure 11

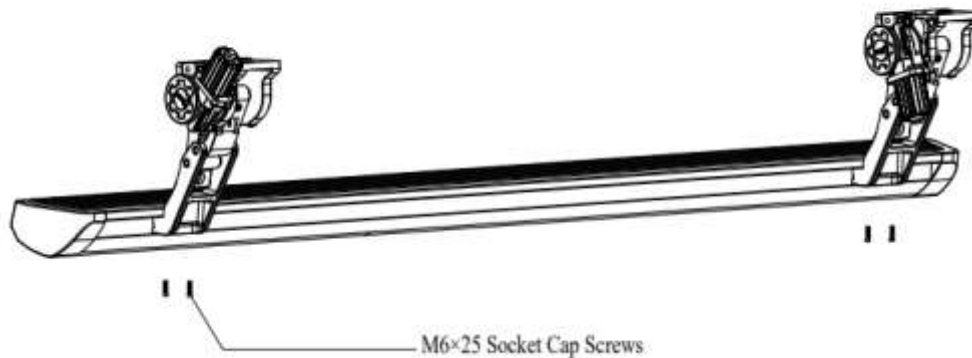

**Step 9:** While still on the passenger side, locate the two holes in the pinch seam below the passenger door (in the middle of the vehicle) Using two M8 hex head bolts, flat washers and spring washers, install the controller module mounting bracket. Using a torque wrench, (tighten to 30Nm)

**Step 10:** Repeat steps 1 through 9 for the driver side of the vehicle.  
(Note: there is no controller module for the driver side, just passenger side)

**Step 11:** Once all motor linkages, protective motor brackets, and running boards are loosely installed align and adjust the running boards to the desired positioning so they match on both sides. Then proceed to fully tighten and torque all hardware as specified: M6 hardware to 8-9 ft-lbs., M8 hardware to 15-18 ft-lbs., and M12 hardware to 40-44 ft-lbs.

Figure 12



M8 x 25 Hex Head Bolts

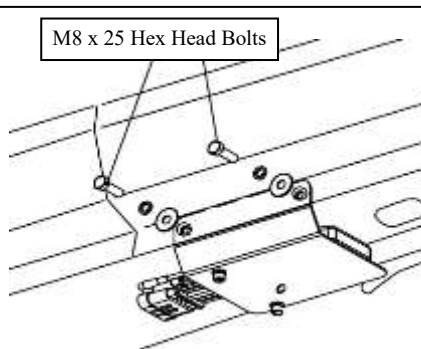



# ELECTRICAL COMPONENT INSTALLATION PROCEDURE

**Step 12:** Remove driver and passenger side Door trim and B-Pillar trim panels by carefully pulling on the panels enough to release them from their plastic retaining clips.



**Step 13:** With the panels removed, on the passenger side, lift carpet back to expose the drain hole under the carpet.

**Step 14:** From under the vehicle, feed the door trigger signal wires (**White & Brown**) and disable/manual switch wires (**Two Black Wires**) into the cab and through the drain hole **Figure 14**.

**Step 15:** Route passenger side door trigger wire (**Brown**) under the carpet to the passenger side B-Pillar, and the driver side door trigger wire (**White**) and the disable switch wires (**Two Black Wires**) through the center console and under the front driver side carpet to the driver side B-Pillar **Figure 15**.

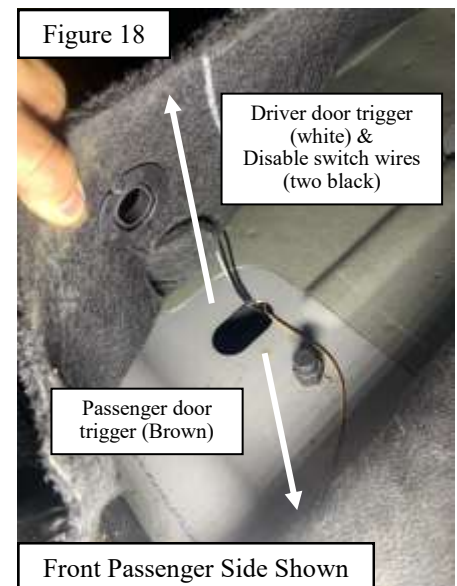
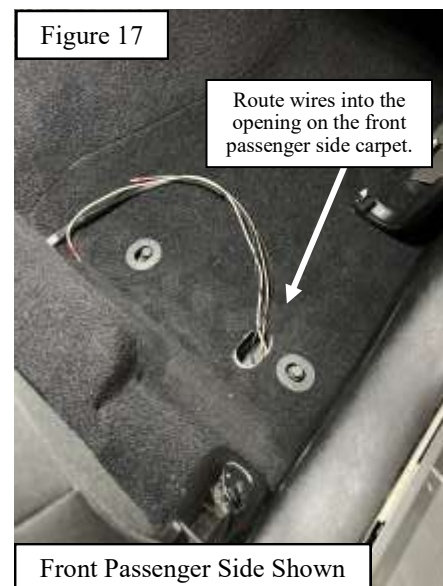

**Step 16:** With the passenger side B-Pillar removed locate the vehicle grounding bolts near the seat belt assembly and gather the **magnetic door switch harness (21)**

**Step 17:** Loosen the top bolt slightly and mount the ground wire fork (**Black Wire**) under the vehicle bolt, then re-tighten. This provides a grounding connection for the magnetic door switch harness. (**Figure 20**).

**Step 18:** Connect the remaining wire with snap in bullet connector (**Black Wire**) to the brown trigger wire. (**Figure 21**)

**Step 19:** On the driver side repeat Steps 12 through 14, to ground the driver side magnetic door switch and connect the bullet connector (**Black Wire**) to the driver side trigger wire (**White Wire**).

### Magnetic Door Switch Harness

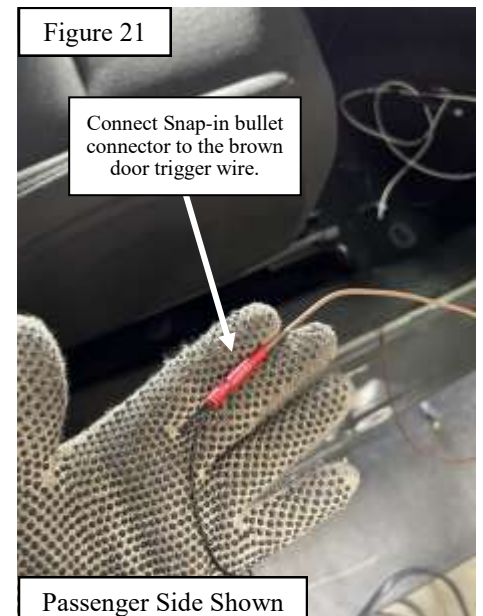
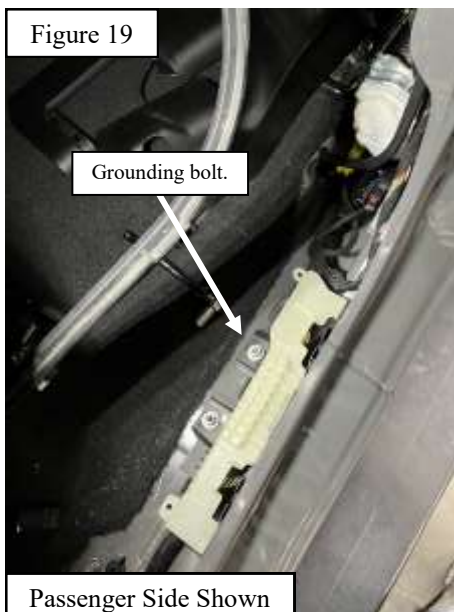
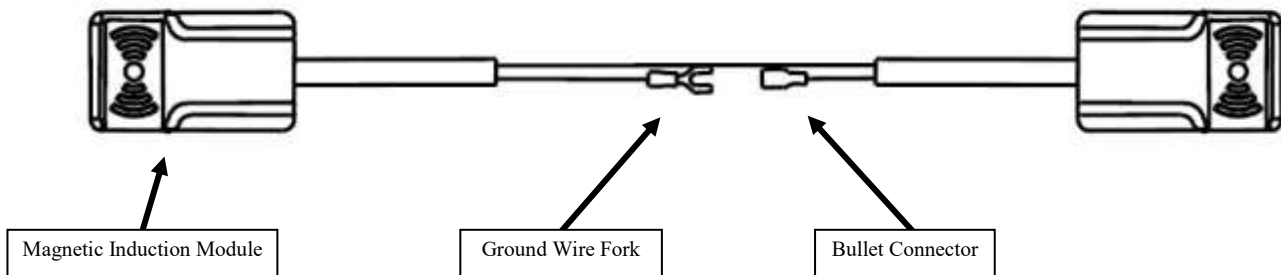

**Step 20:** You are now ready to stick the induction modules and magnets to the B-Pillar and doors. Before doing this clean both surfaces with a damp rag with 50/50 mix of isopropyl alcohol and water.

**Step 21:** Once the surface is completely dry, remove backing from the front magnetic induction module and Place it 1.5” under the Front B-Pannel door striker located in the front passenger side door jamb and “stick it in place”. (See figure 22 for reference)

**Step 22:** For the front passenger magnet position, use a ruler and measure 1.5” down from the center of the door latch as a reference point. Prepare the surface by cleaning with a damp rag and 50/50 mix of isopropyl alcohol and water and proceed to place the magnet onto the door. (See figure 23 for reference)

**Important:** For these steps you need to make sure the magnetic induction modules line up with the door magnets when door is closed, failure to do this will mean the step bar will not drop when door is opened.

### Magnetic Induction Module Arrangement

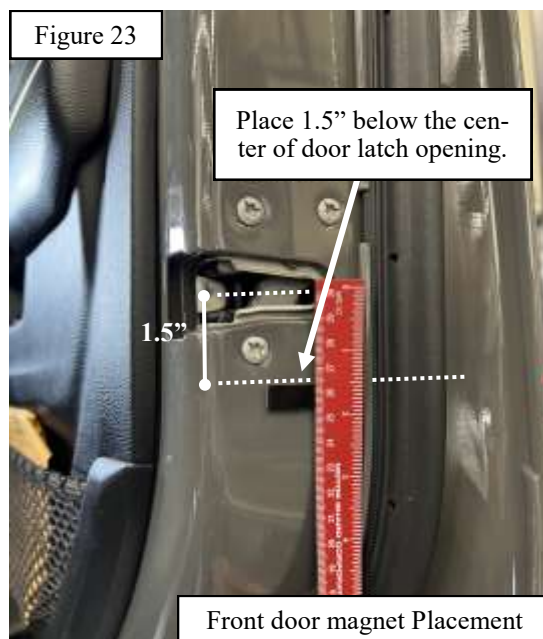
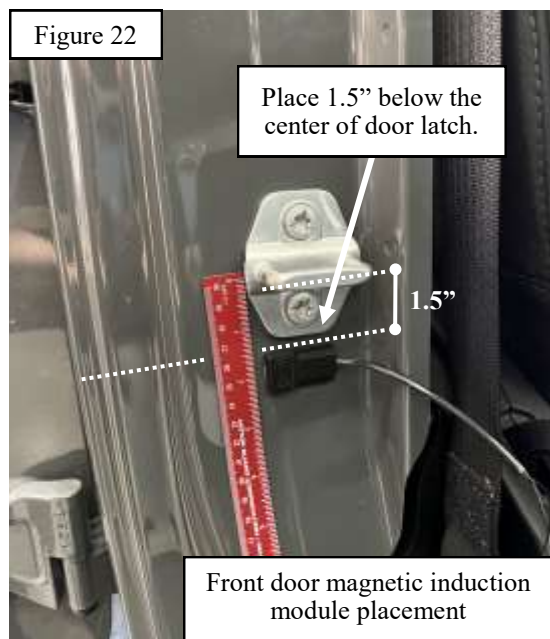
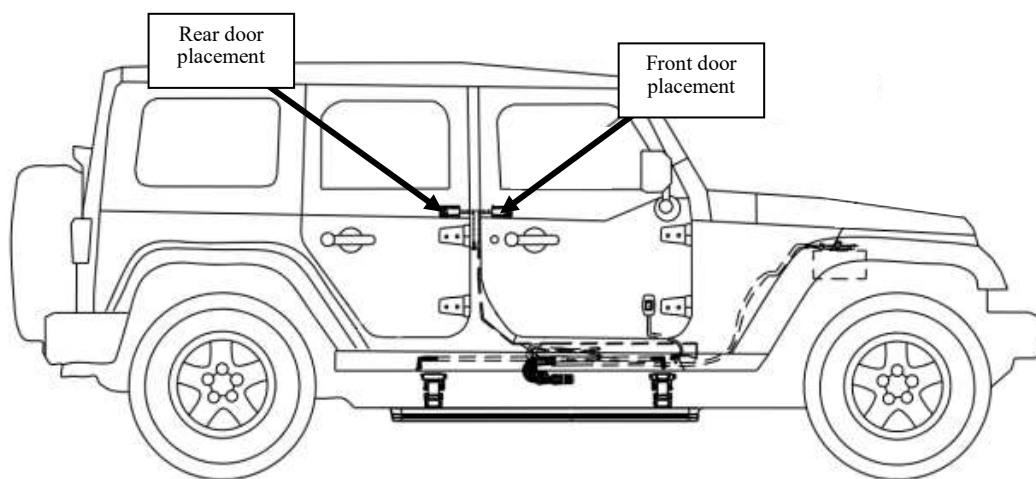

Westin Automotive Products, Inc.  
320 W. Covina Blvd  
San Dimas, Ca. 91773

Thank you for choosing Westin products  
for additional installation assistance please call  
Customer Service (800) 793-7846  
www.westinautomotive.com

**Step 23:** Now move to the rear passenger door to mount the rear induction module and magnet. Before doing this clean both surfaces with a damp rag with 50/50 mix of isopropyl alcohol and water.

**Step 24:** Remove the backing from the magnetic induction module and place it in the center of the two bolts on the rear door hinge. (See figure 24 for reference)

**Step 25:** For the rear passenger door magnet, position it 0.5" inch below the bottom of the plastic door casing. So that it will line up with induction module when door is closed. (See figure 25 for reference)

**Step 26:** Repeat Steps 16 through 21 on the driver side, mounting the remaining magnetic induction modules and door magnets.

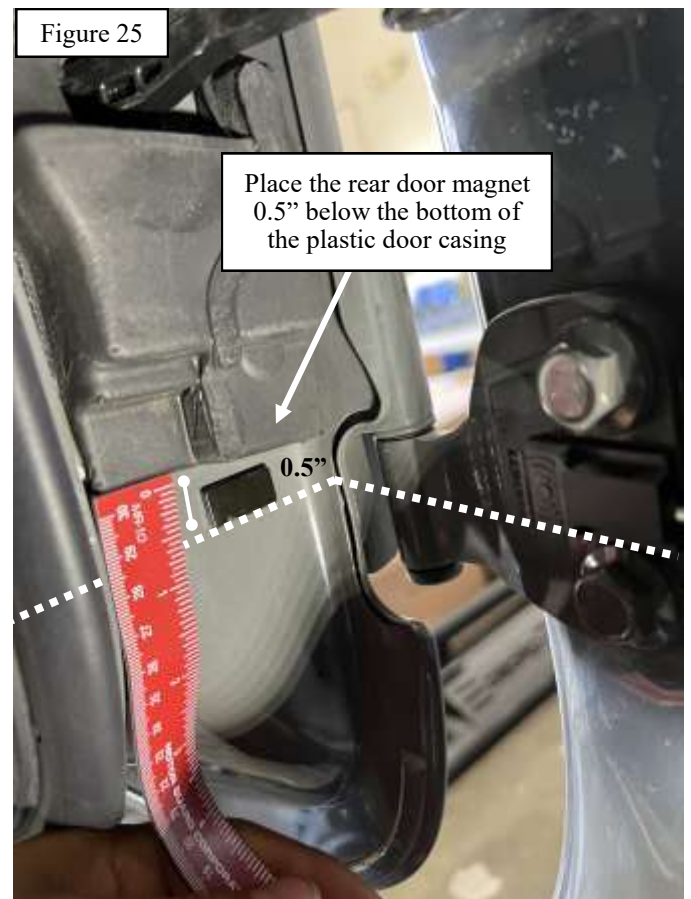
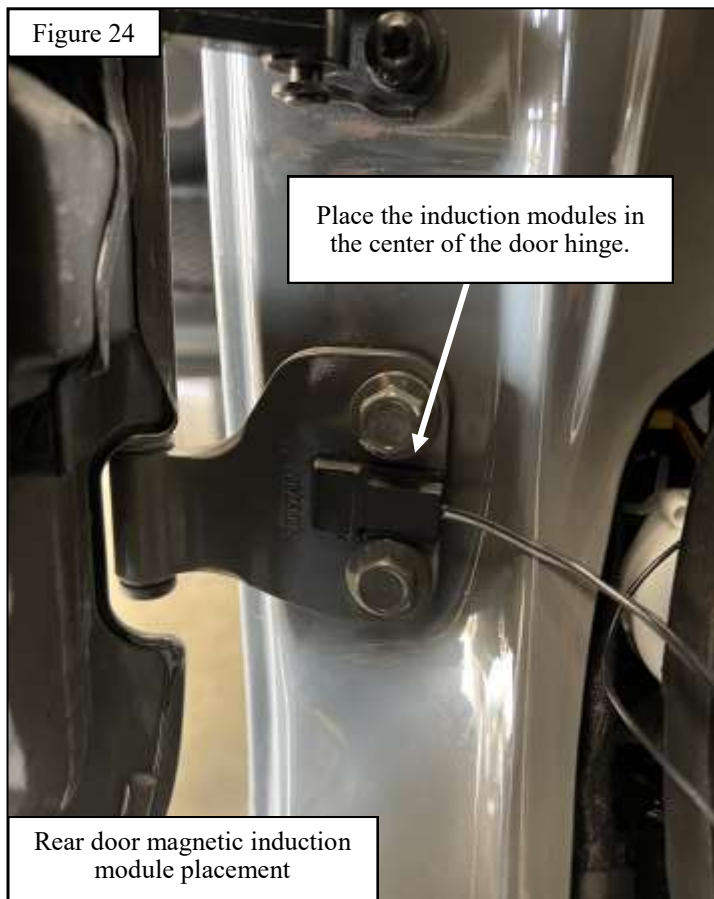

**Step 27:** Now, on the drivers side find the two manual switch wires (**Two Black Wires**) that you previously routed from the passenger side, and connect them to the manual switch.

**Step 28:** Find your preferred spot on the front driver side, prepare surface by cleaning with a damp rag and 50/50 mix of isopropyl alcohol and water and proceed to place the manual switch.

Neatly tuck or zip tie the extra wiring away so that the switch cannot be tugged or pulled accidentally.

Recommended to mount off center console on drivers side **Figure 26**.

**Important: Keep switch and wires far from driver pedals.**

**Step 29:** Moving back to the wiring underneath the vehicle, route the two fused power wires towards the front of the vehicle.

Pull back the driver side fender liner and feed the fused power wires into the engine compartment **Figure 27**.

Remove the two fuses from both of the fused power wires and leave them disconnected from the battery for now.

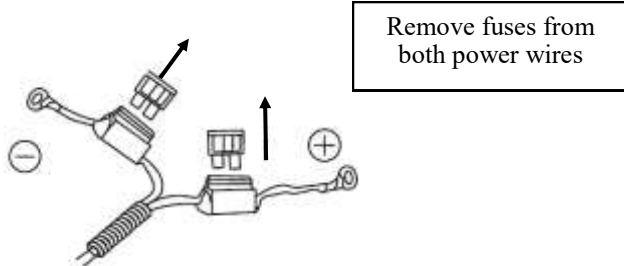
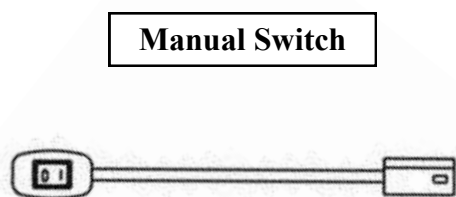

Figure 26



Figure 27



**Step 30:** underneath the vehicle, route the electrical harness to the designated locations of the control module and motor linkages.

Route the corresponding male connector plug to where the corresponding female connector will be per the labeling on the harness. For example, the male connector labeled “Front Left,” will be routed to the front driver side of the vehicle, and the “Front Right” should be routed to the front passenger side of the vehicle **Figure 29**.

The male connectors for the control module will be routed to the center passenger side. Also plug these in to their respective female plugs on the control module.

**Step 31:** After wiring the harness to their corresponding locations, go through and tuck all excess wiring away neatly and secure all wiring with zip ties. When routing, keep clear from any moving parts and avoid direct contact with the exhaust system **Figure 30**.

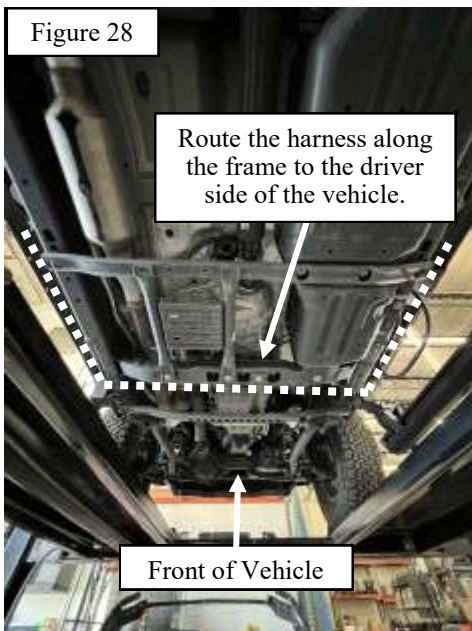
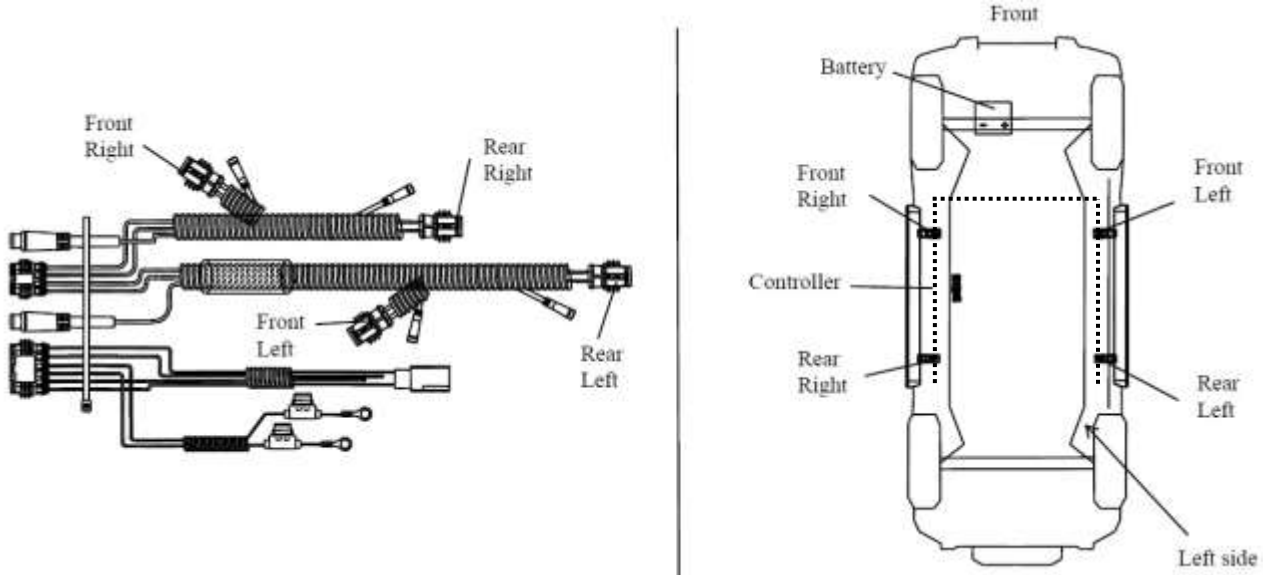

**Step 32:** Locate the LED Lights (Item 11). Align the arrow from the LED Light male connector to the arrow on the female connector on the main wiring harness. Prepare the designated mounting surfaces on the vehicle frame rail or on the body of the vehicle by cleaning it with a damp rag and 50/50 mix of isopropyl alcohol and water. Allow the surface to dry completely before peeling the backing of the LED lights and mount to the mounting surface. See Figures 30 & 31 for reference.

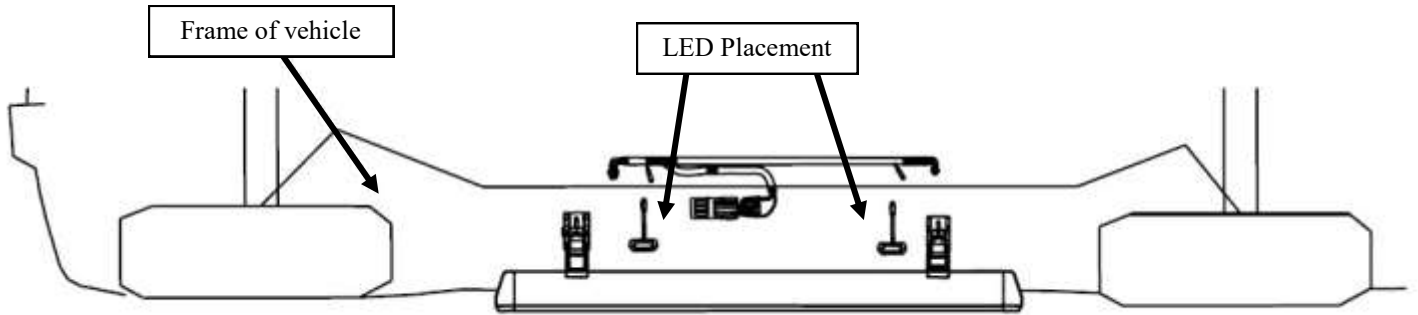

**Step 33:** Almost there! Return to the vehicle battery and connect the ring terminals to the battery positive and negative posts.

**Step 34:** After the battery is connected reinstall the 20 Amp fuses back on the main negative and positive 12V power leads of the main power harness.

**Step 35:** Connect the battery. Begin with the positive terminal, followed by the negative terminal.

**Your Westin Power Running Boards should now be operational.**

**Step 36:** Open and close all four doors to test the operation of your new Westin Power Running Boards. Also, test the manual switch by leaving the driver door open and flipping the switch to “O” or off this will signal the running boards to retract to the stowed position and will disable any further operation until the switch is flipped to the “I” or on position.

## INSTALLATION COMPLETE



### CARE INSTRUCTIONS

- REGULAR WAXING IS RECOMMENDED. DO NOT USE ANY TYPE OF POLISH OR WAX THAT MAY CONTAIN ABRASIVES.
- STAINLESS STEEL PRODUCTS CAN BE CLEANED WITH MILD SOAP AND WATER. STAINLESS STEEL POLISH SHOULD BE USED TO POLISH SMALL SCRATCHES.
- GLOSS BLACK FINISHES SHOULD BE CLEANED WITH MILD SOAP AND WATER.

**WESTIN**

Westin Automotive Products, Inc.  
320 W. Covina Blvd  
San Dimas, Ca. 91773





## WARNING



Failure to follow these instructions could lead to death, personal injury, and / or property damage.

Failure to follow these instructions could lead to death, personal injury, and / or property damage.

### **FASTENERS:**

All Westin supplied fasteners must be utilized and installed in accordance with the installation instructions and apply torque to the specifications as defined. **DOUBLE CHECK ALL FASTENERS BEFORE INITIAL USE, AND PERIODICALLY IN THE FUTURE TO ENSURE PROPER FUNCTION AND SAFETY.**

### **DRILLING:**

Most Westin products do not require drilling for installation. If drilling is defined as required, use caution when drilling a vehicle. **FAILURE TO REVIEW AN AREA TO BE DRILLED MAY RESULT IN PERSONAL INJURY AND/OR INJURY TO OTHERS AS WELL AS VEHICLE DAMAGE.**

### **EYE PROTECTION:**

**ALWAYS WEAR SAFETY GLASSES OR GOGGLES DURING THE INSTALLATION PROCESS TO AVOID PERSONAL INJURY.**

### **MAXIMUM TOWING/CARRYING CAPACITY:** (if applicable)

The Westin Receiver Hitches will have a visible tow rating label affixed directly on the product. User should never exceed the vehicle manufacturers maximum tow and weight rating regardless of the capacity of the hitch. **FAILURE TO FOLLOW THESE GUIDELINES WILL VOID THE WESTIN WARRANTY AND MAY RESULT IN PERSONAL INJURY AND/OR INJURY TO OTHERS AS WELL AS VEHICLE DAMAGE.**

### **FOR CALIFORNIA RESIDENTS ONLY-PROP 65 WARNING:**

Some products may contain chemicals such as DEHP, which can cause cancer, birth defects or other reproductive harm. For more info go to [www.p65warnings.ca.gov](http://www.p65warnings.ca.gov)



Westin Automotive Products, Inc.  
320 W. Covina Blvd  
San Dimas, Ca. 91773