

INSTALLATION INSTRUCTIONS



HDX LED GRILLE
APPLICATION:
2015-2017 Ford F150
PART NUMBER:
34-1045

ITEM	QUANTITY	DESCRIPTION	TOOLS NEEDED
1	1	HDX GRILLE	10MM SOCKET / WRATCHET WRENCH
2	5	M6 HEX HEAD CAP SCREW (YELLOW ZINC)	
3	5	M6 HEX COUPLING NUT (YELLOW ZINC)	13MM SOCKET
4	5	M6 SPLIT LOCK WASHER (YELLOW ZINC)	TORQUE WRENCH
5	5	M6 SMALL FLAT WASHER (YELLOW ZINC)	8MM SOCKET
6	5	M6 LARGE FLAT WASHER (YELLOW ZINC)	6MM ALLEN KEY

ANTI-SEIZE LUBRICANT MUST BE USED ON ALL STAINLESS STEEL FASTENERS TO PREVENT THREAD DAMAGE AND GALLING

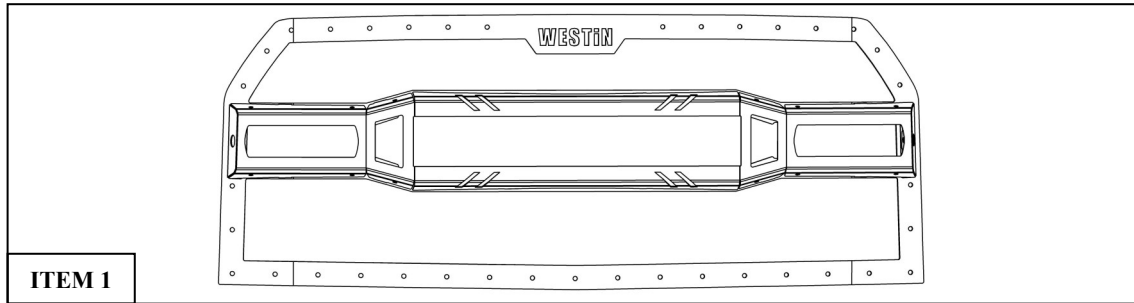

PROCEDURE

- Remove contents from box, verify if all parts listed are present and free from damage. Carefully read and understand all instructions before attempting installation.
Failure to identify damage before installation could lead to a rejection of any claim.
- Starting on either side, remove the headlight trim panel by removing two bolts on the side near the front tire and a plastic clip on the top near the engine. Start removing the headlight trim from the top first and then the bottom. Then work your way towards removing the middle portion. See **Figures 1 - 3**. Repeat step for opposite side.

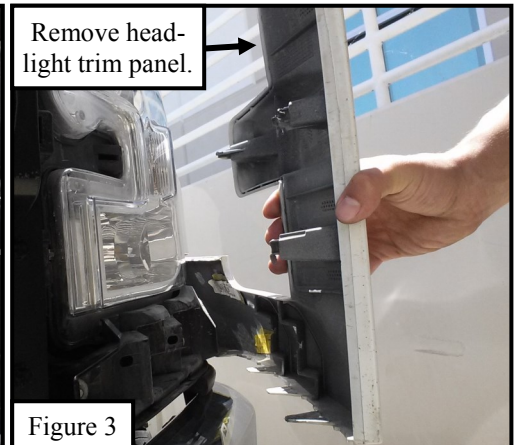
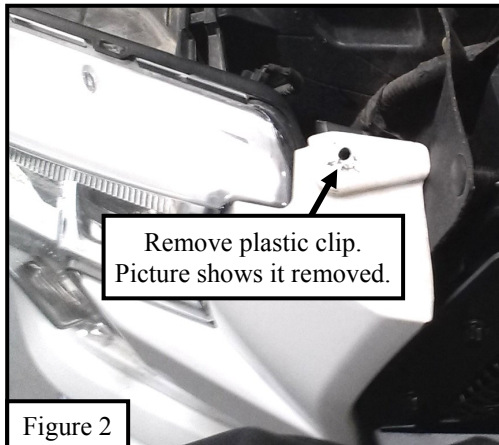
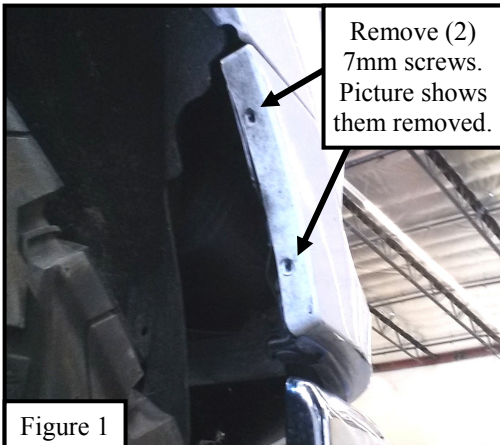

- Remove the (2) bolts that hold the bottom portion of the grille. See **Figure 4**.
- Then un-clip the rubber shield from each side of the grille. See **Figure 5**.

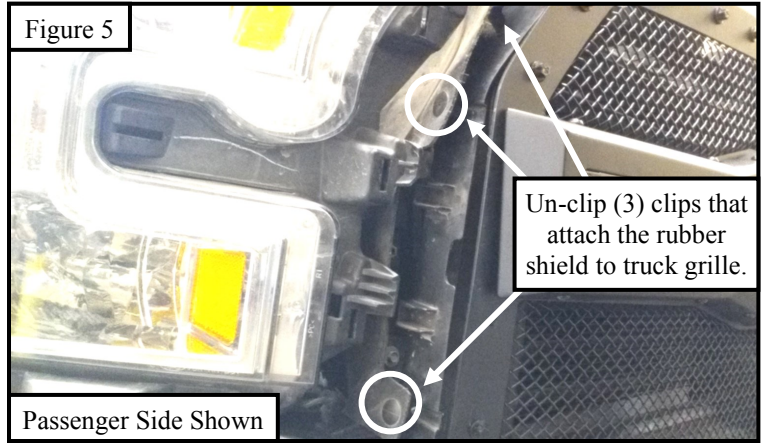
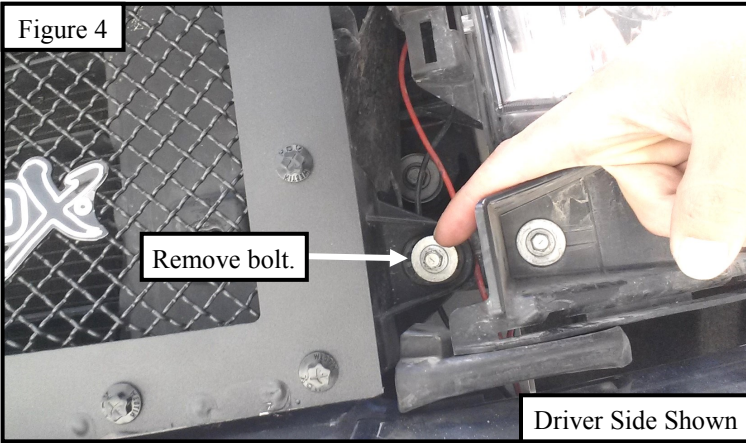

- Locate plastic push pins on the radiator cover. Remove the plastic push pins in order to remove the radiator cover. See **Figure 6**. **Note:** Un-plug any electrical connectors that connect to the grille.
- Remove (4) bolts that attach the grille to the vehicle. Then lift the grille up and off the truck. See **Figure 6**.
- Once the grille is off, remove the (4) push pins that hold the top portion of the grille can be pulled off. See **Figure 7**.

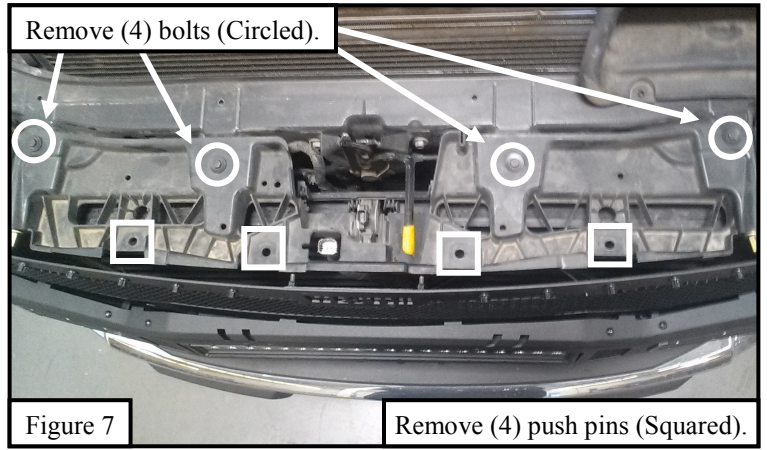
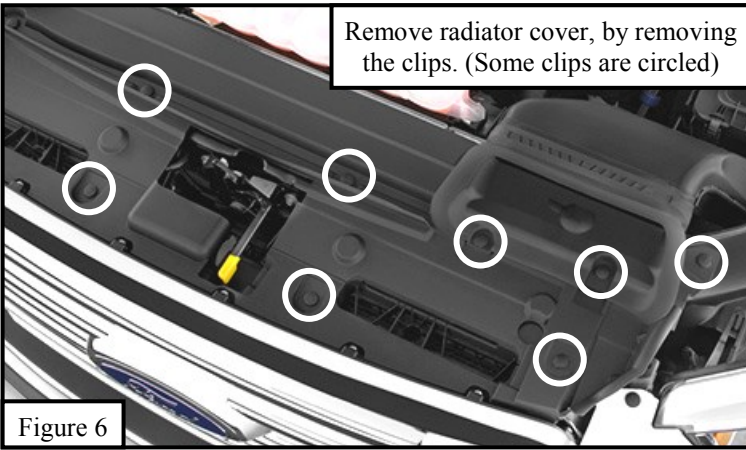

- Remove (4) nuts on the grille shutter and center bolt to allow removal of shutters from grille. See **Figure 8**. **Note:** The (4) nuts attach to bolts that are attached to the grille, may need to hold the bolts to remove the nuts more easily. Remove (3) tinnerman nuts at bottom of shutters. See **Figure 8**.
- Use the provided (5) M6 hex head cap screws, (5) M6 hex coupling nuts, (5) M6 split lock washers, (5) M6 large flat washers, and (5) M6 small flat washers (Items 2-5) to secure the factory grille shutter onto the HDX Grille. **Figures 9 - 11**.

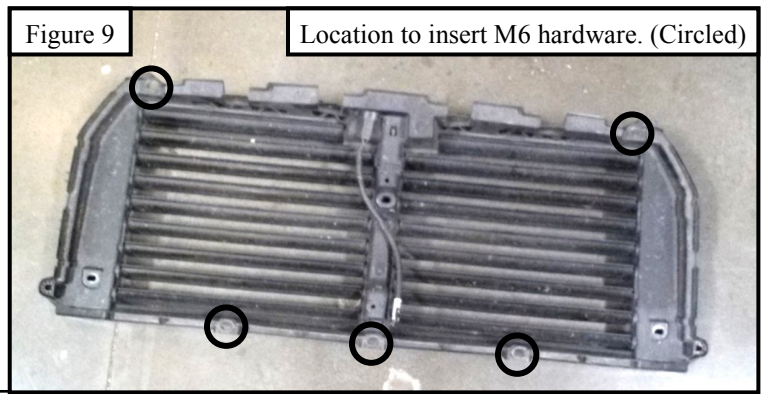
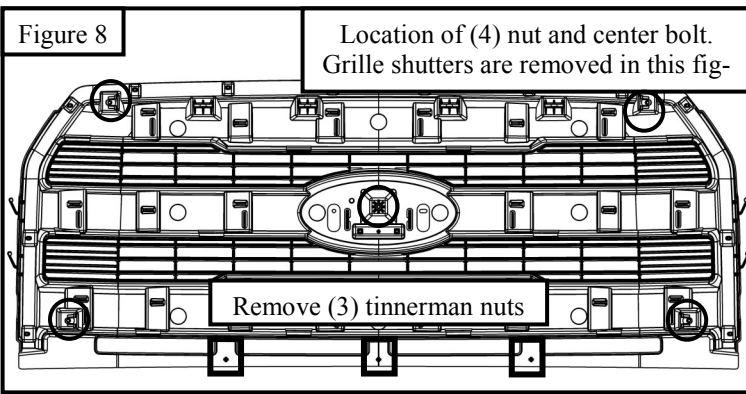

Figure 10

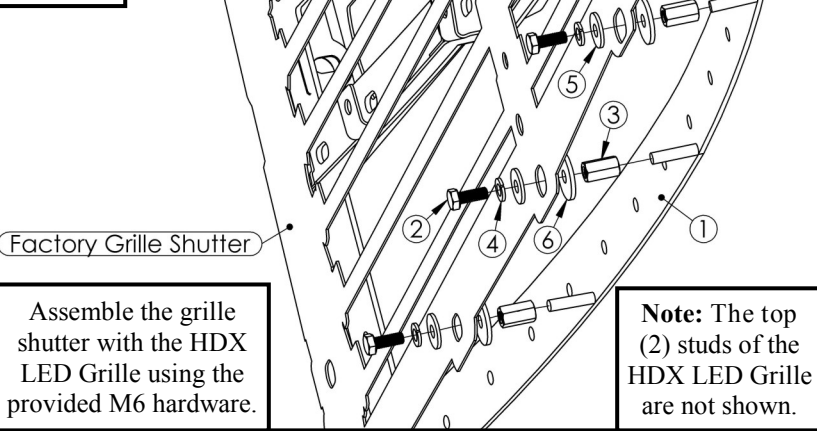
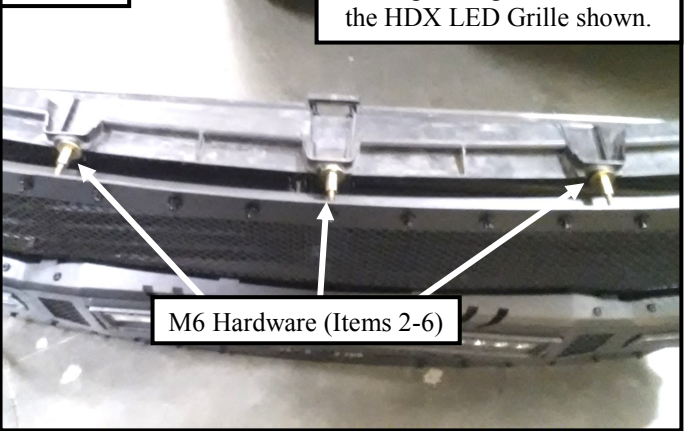

Figure 11



10. Align and adjust the HDX LED Grille guard onto the grille shutters as necessary then torque M6 hardware to 5-7 ft-lbs.
11. Install the grille shutter with the HDX LED Grille onto the vehicle using the factory hardware as removed in **Steps 3 and 6**. Re-clip the rubber shield that was unclipped in **Step 4**.
12. Re-attach the headlight trim panel that was removed in **Step 2** and the radiator cover that was removed in **Step 5**.
13. Refer to wiring instructions on **Page 4** in order to connect LED lights to vehicle.



CARE INSTRUCTIONS

- REGULAR WAXING IS RECOMMENDED. DO NOT USE ANY TYPE OF POLISH OR WAX THAT MAY CONTAIN ABRASIVES.
- STAINLESS STEEL PRODUCTS CAN BE CLEANED WITH MILD SOAP AND WATER. STAINLESS STEEL POLISH SHOULD BE USED TO POLISH SMALL SCRATCHES.
- GLOSS BLACK FINISHES SHOULD BE CLEANED WITH MILD SOAP AND WATER.

WESTIN Westin Automotive Products, Inc.
 320 W. Covina Blvd
 San Dimas, Ca. 91773

Thank you for choosing Westin products
 for additional installation assistance please call
 Customer Service (800) 793-7846

WIRING INSTRUCTIONS (CAUTION):

1. Disconnect ground connection from battery (-) to avoid accidental short circuits before attempting to connect electrical wires.
2. When running wires, avoid areas of excessive heat, vibration, pinch or rotation when securing harness to vehicle.
3. Always use a fused (+) positive supply source.
4. This light becomes hot under continuous use. Do not remove or touch the casting for at least 30 minutes after the lamp has been turned off.

WESTIN recommends using a professional for this installation. Refer to Figure 12 below.

1. Locate the wiring harness and mount the switch in a convenient location where it is easily accessible from the drivers seat. **Note:** *The switch will need to be removed from the wiring harness so that the rest of the harness can be routed from the engine bay to the cabin.*
2. Route the wiring harness wire, specifically the fuse and relay, from the positive battery terminal along the firewalls existing wire routes. **Note:** *Tape as necessary to correct slack.*
3. Secure the relay by either drilling or using a pre-existing bolt along the chassis that is not connected to any other wire.
4. Run the switch harness through the firewall preferably through the pre-existing rubber plug that is used to run the OEM wiring harness from the engine bay to fuse box. **Note:** *Reconnect the switch to the wiring harness.*
5. Place the LED plug wire along the fender chassis where it will not get pinched and away from any moving parts (fan, pulleys etc.).
6. Run the attached wire from the LED Light Bar as previously mentioned away from any moving parts.
7. Connect both ends of wiring connectors from LED light bar and wiring harness.
8. Re-connect battery terminals, attach the red (+) wire to battery positive, and the black (-) wire to ground. **Note:** *Add dielectric grease (not supplied).*
9. Turn on the switch to make sure if the light works. If not, please check carefully if the wiring installation is correct.

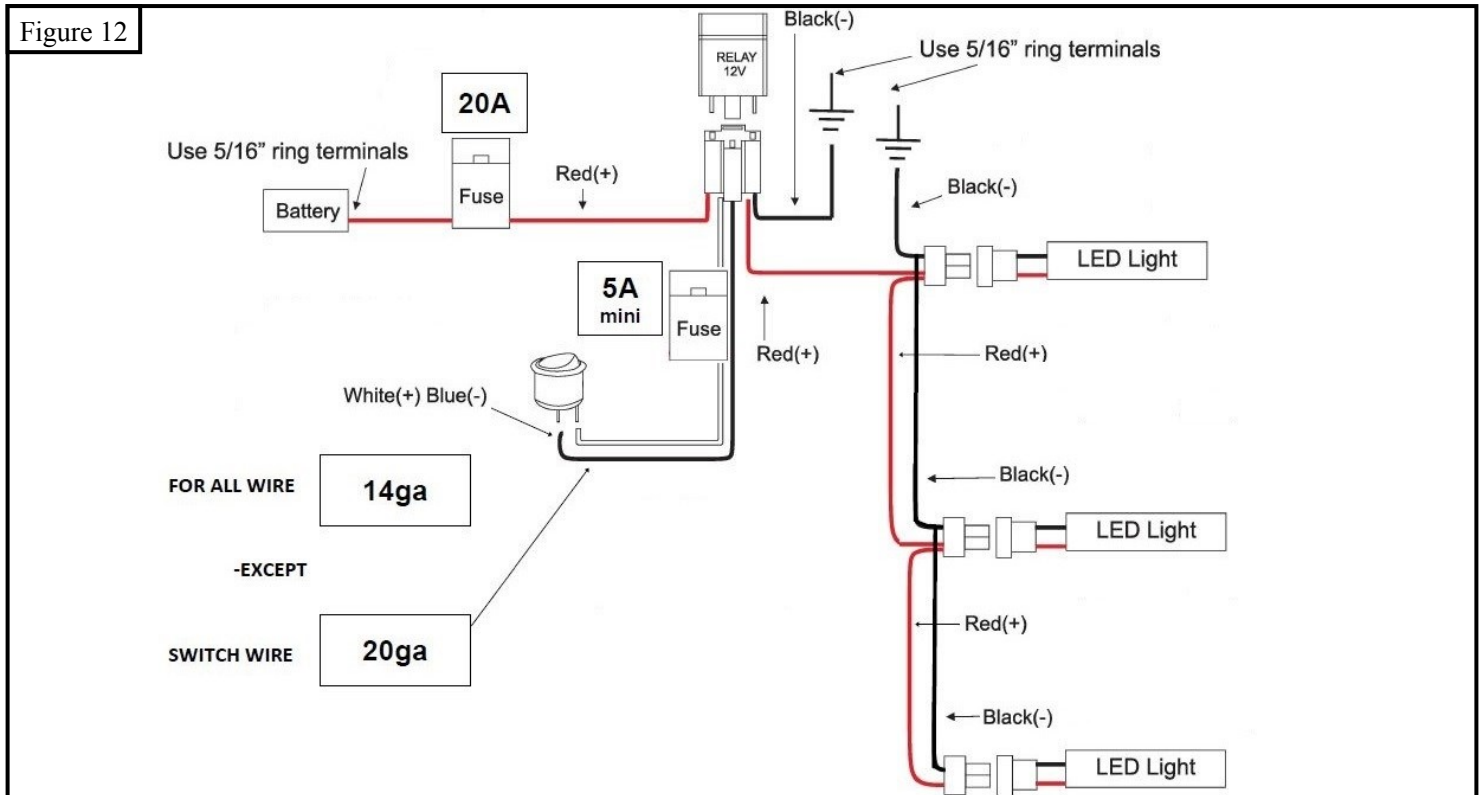



WARNING



Failure to follow these instructions could lead to death, personal injury, and / or property damage.

FASTENERS:

All Westin supplied fasteners must be utilized and installed in accordance with the installation instructions and apply torque to the specifications as defined. **DOUBLE CHECK ALL FASTENERS BEFORE INITIAL USE, AND PERIODICALLY IN THE FUTURE TO ENSURE PROPER FUNCTION AND SAFETY.**

DRILLING:

Most Westin products do not require drilling for installation. If drilling is defined as required, use caution when drilling a vehicle. **FAILURE TO REVIEW AN AREA TO BE DRILLED MAY RESULT IN PERSONAL INJURY AND/OR INJURY TO OTHERS AS WELL AS VEHICLE DAMAGE.**

EYE PROTECTION:

ALWAYS WEAR SAFETY GLASSES OR GOGGLES DURING THE INSTALLATION PROCESS TO AVOID PERSONAL INJURY.

MAXIMUM TOWING/CARRYING CAPACITY:

The Westin Receiver Hitches will have a visible tow rating label affixed directly on the product. User should never exceed the vehicle manufacturers maximum tow and weight rating regardless of the capacity of the hitch. **FAILURE TO FOLLOW THESE GUIDELINES WILL VOID THE WESTIN WARRANTY AND MAY RESULT IN PERSONAL INJURY AND/OR INJURY TO OTHERS AS WELL AS VEHICLE DAMAGE.**