

INSTALLATION INSTRUCTIONS

HDX Sensor Grille Guard



APPLICATION:
2020-2024 Chevrolet Silverado 2500/3500 (with Front Sensors)
PART NUMBER:
57-3995S

ITEM	QUANTITY	DESCRIPTION	TOOLS NEEDED
1	1	GRILLE GUARD	10MM SOCKET
2	1	LOWER DRIVER MOUNTING BRACKET	16MM SOCKET
3	1	LOWER PASSENGER MOUNTING BRACKET	16MM WRENCH
4	1	DRIVER INSIDE SUPPORT BRACKET	18MM SOCKET
5	1	PASSENGER INSIDE SUPPORT BRACKET	18MM WRENCH
6	1	DRIVER UPPER STRAP "A"	HAMMER
7	1	PASSENGER UPPER STRAP "A"	UTILITY KNIFE
8	2	SHORT M12 HEX HEAD BOLT (YELLOW ZINC)	FLAT HEAD SCREWDRIVER
9	4	LONG M12 HEX HAD BOLT (YELLOW ZINC)	
10	6	M12 SPLIT LOCK WASHER (YELLOW ZINC)	RATCHET
11	12	M12 FLAT WASHER (YELLOW ZINC)	TORQUE WRENCH
12	6	M12 HEX NUT (YELLOW ZINC)	PRYBAR
13	2	M10 BUTTON HEAD BOLT (BLACK ZINC)	13MM SOCKET
14	2	M10 BELLVILLE WASHER (BLACK ZINC)	
15	2	M10 SERRATED FLANGE NUT (BLACK ZINC)	
16	6	M12 BUTTON HEAD BOLT (BLACK ZINC)	
17	6	M12 SERRATED FLANGE NUT (BLACK ZINC)	
18	6	M12 BELLVILLE WASHER	
19	4	M6 HEX HEAD CAP SCREW (BLACK ZINC)	
20	4	M6 SPLIT LOCK WASHER (BLACK ZINC)	
21	4	M6 FLAT WASHER (BLACK ZINC)	
22	1	DRIVER CUTTING TEMPLATE	
23	1	PASSENGER CUTTING TEMPLATE	
24	4	SENSOR PLUG	
25	8	PAN HEAD SCREWS	
26	4	HARNESS EXTENSION	
27	2	DRIVER SIDE SENSOR TAB	
28	2	PASSENGER SIDE SENSOR TAB	
29	8	ZIP TIES	
30	4	DOUBLE SIDED TAPE SQUARES	
31	2	FISH WIRE	

ANTI-SEIZE LUBRICANT MUST BE USED ON ALL STAINLESS STEEL FASTENERS TO PREVENT THREAD DAMAGE AND GALLING.

ITEM	QUANTITY	DESCRIPTION	
32	4	TUBE COVERS	
33	4	SENSOR RETAINERS	
34	1	DRIVER CUTTING TEMPLATE "B"	
35	1	PASSENGER CUTTING TEMPLATE "B"	
36	1	DRIVER SUPPORT BRACKET "B"	
37	1	PASSENGER SUPPORT BRACKET "B"	
38	1	DRIVER CUTTING TEMPLATE "A"	
39	1	PASSENGER CUTTING TEMPLATE "A"	

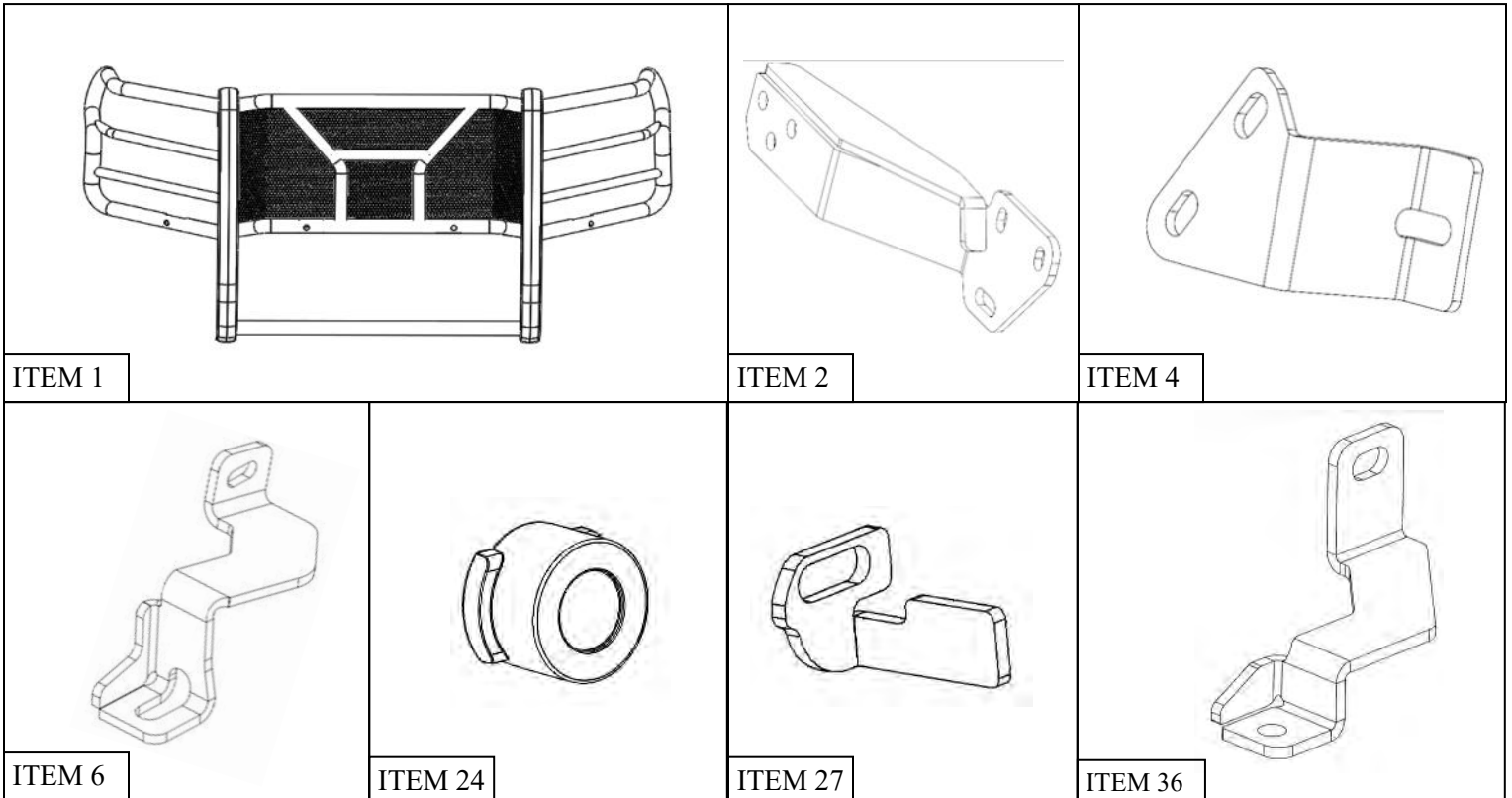

PROCEDURE

1. Remove contents from box, verify if all parts listed are present and free from damage.
 Carefully read and understand all instructions before attempting installation.
Failure to identify damage before installation could lead to a rejection of any claim.

2. Open the hood of the vehicle and remove the plastic cover at the front using a pry tool. See **Figure 1**.
3. Remove the four bolts holding the grille in place. See **Figure 2**.
4. Remove 2 bolts attaching wheel well cover to filler panel. See **Figure 3**.

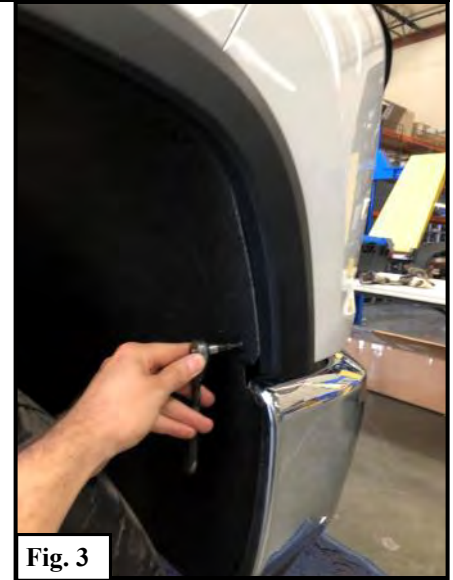
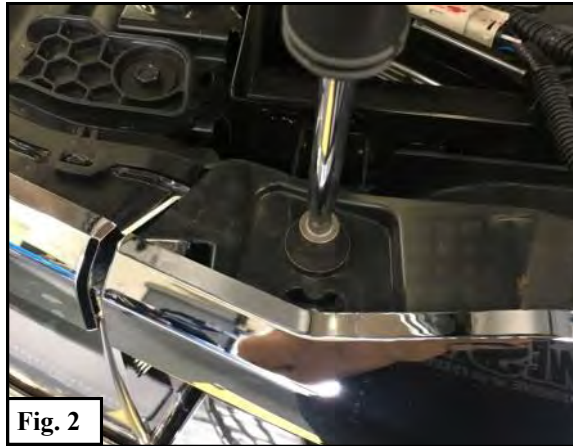

5. Pry off fenders to access the filler panel clips. See **Figure 4**.
6. Pry filler panel off removing any necessary bolts. See **Figure 5**.
7. Disconnect any electrical plugs and any bolts still attaching the grille to the vehicle. See **Figure 6**.
8. Pry remaining clips attaching the grille to the vehicle to remove the grille.

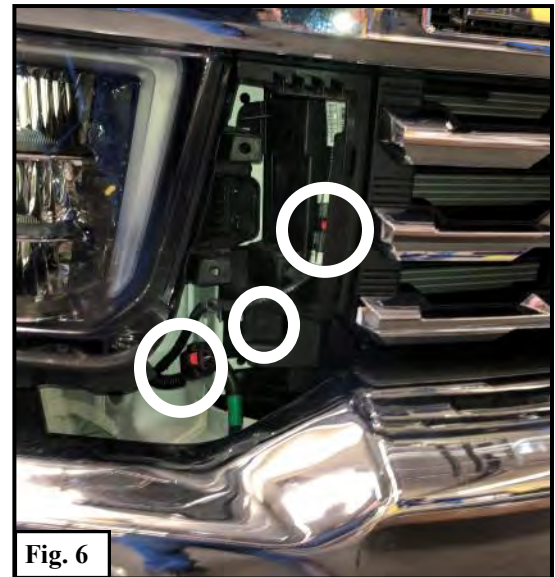
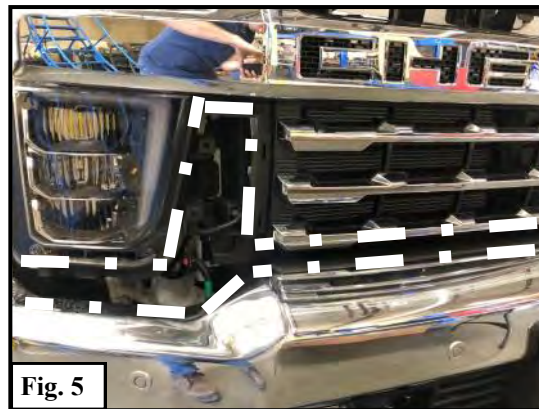

9. Remove 4 upper bumper bolts attaching the bumper to the frame and remove 2 bottom bolts attaching bumper arm to the frame. See **Figure 7 & 8.**

10. **Remove Bumper.**

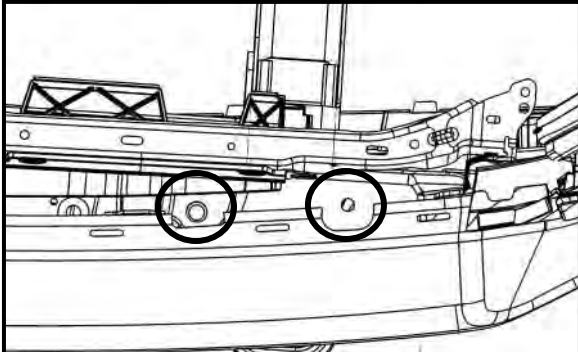

Fig. 7

Bolts will be exposed after removing the grille and lifting the plastic covering them

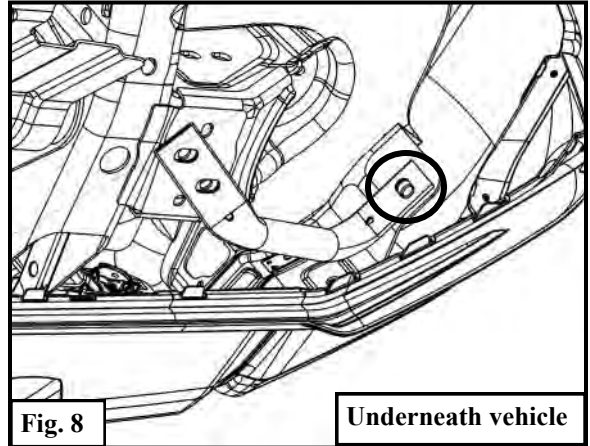

Fig. 8

Underneath vehicle

11. Unbolt the pre-installed tube covers from the grille guard by unscrewing M6 button head bolts. See **Figure 9 & 10**

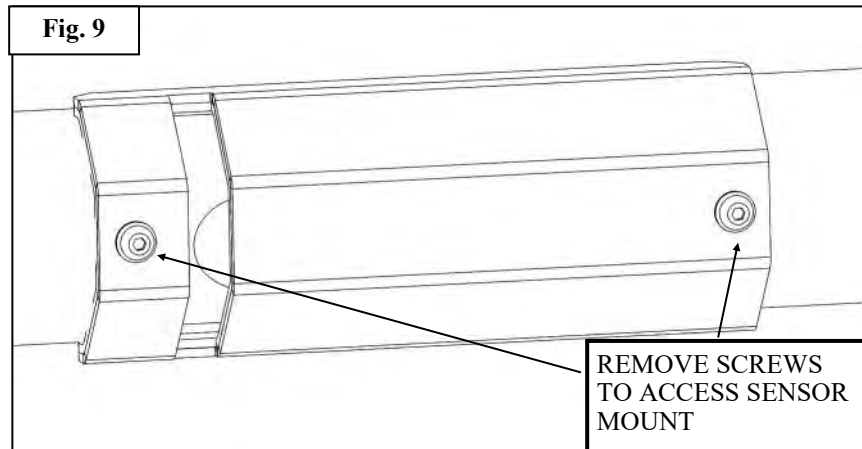

Fig. 9

REMOVE SCREWS
TO ACCESS SENSOR
MOUNT

12. Mount the sensors onto the Grille Guard (1) in the same orientation that they were on the OEM bumper using the Sensor Tabs (27-28) and the provided M6 hardware. See **Figure 10,11, & 12.**

Note: The double sided tape (30) may be used to secure the Sensor Tabs to the Sensor.

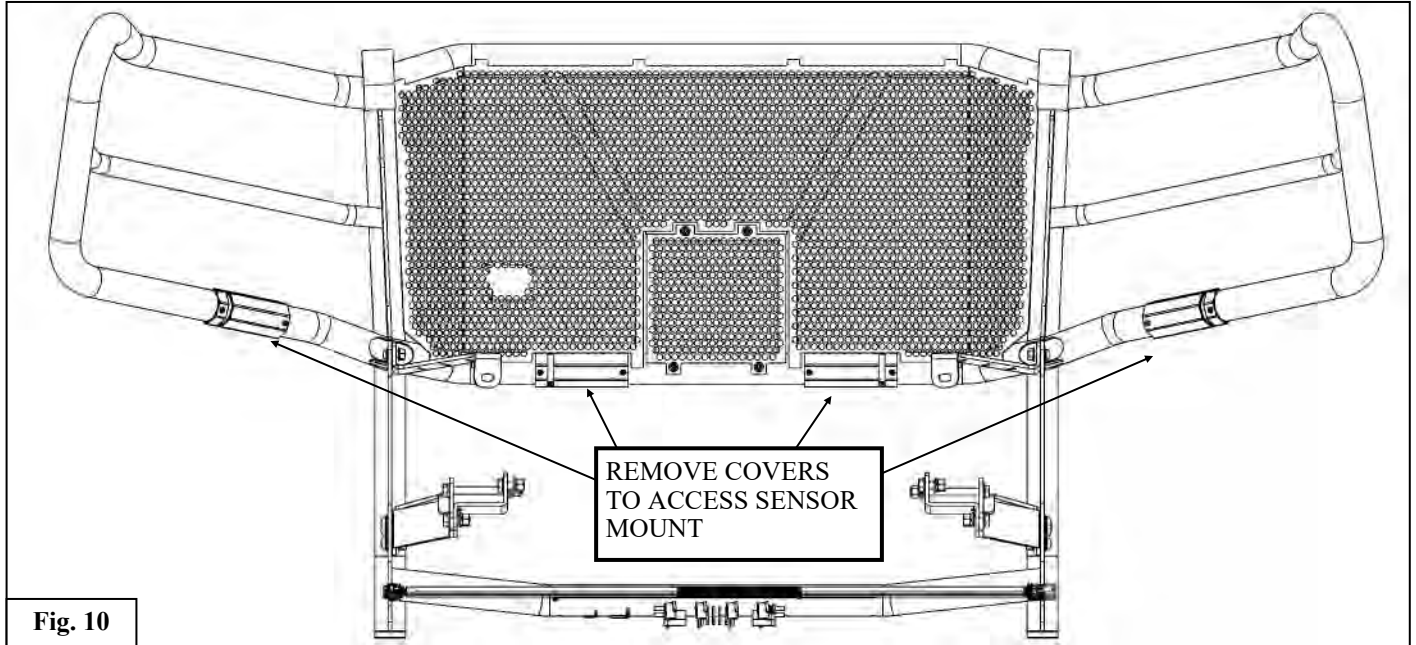

Fig. 10

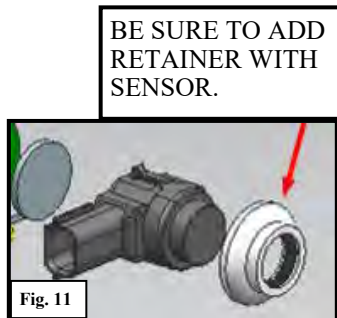

Fig. 11

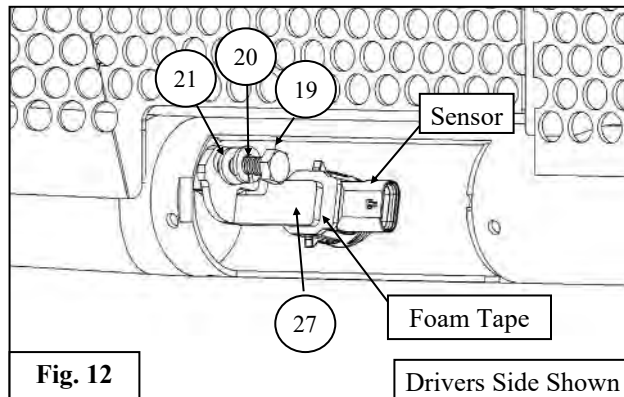
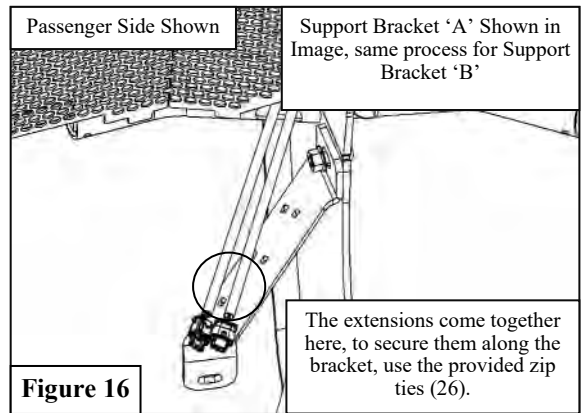
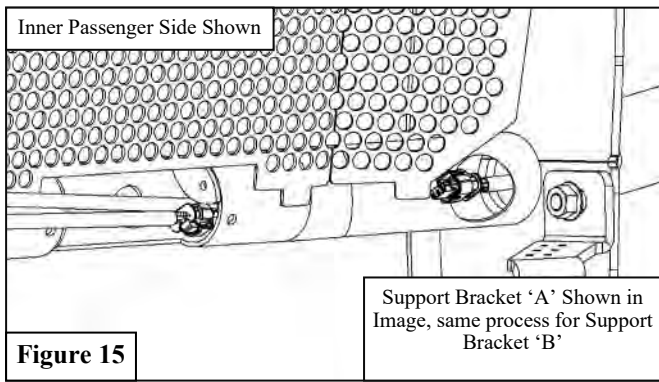
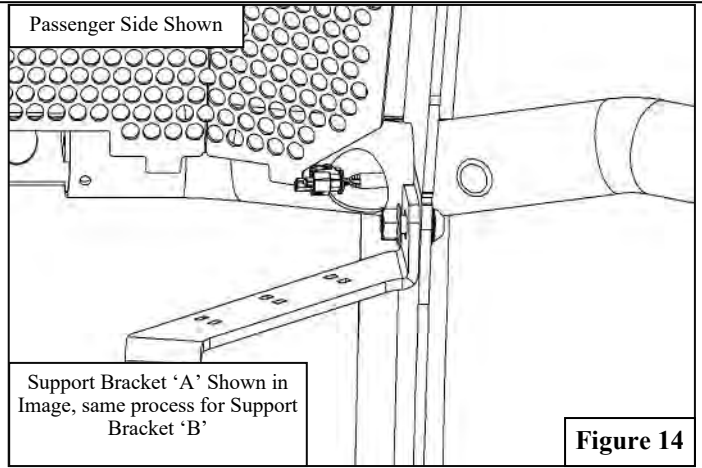
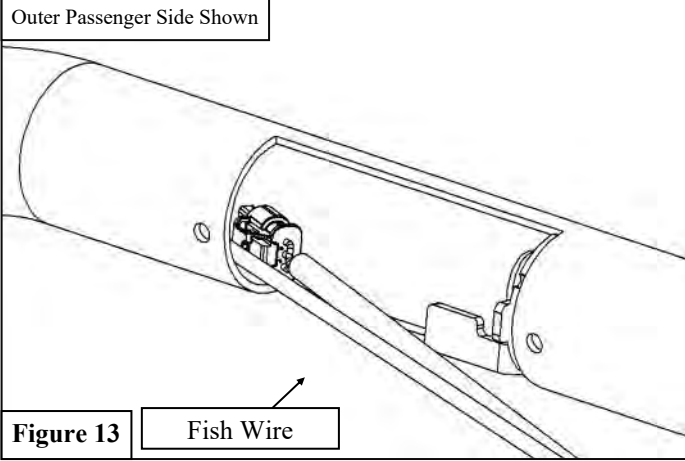
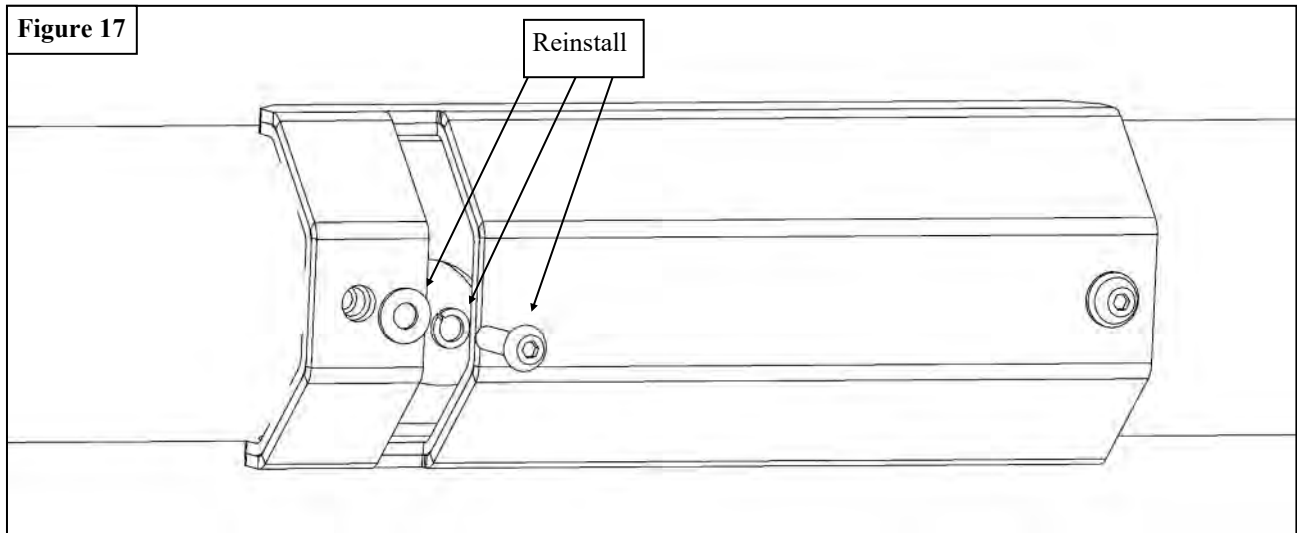

Fig. 12

13. Locate the Harness Extensions (26) and route the extension wire using the supplied Fish Wire (31) through the grille guard tube covers before installing the sensors. See Figures 13-16.



14. Reinstall the sensor covers using the same hardware you removed. See Figure 17.



15. Locate the lower driver mounting and support brackets for the Grille Guard. Using the supplied M12 hardware, loosely install the mounting brackets on to the frame. The mounting bracket and support bracket (2-5) sandwich the frame. See **Figure 18 & 19**.
16. Repeat on the passenger side.

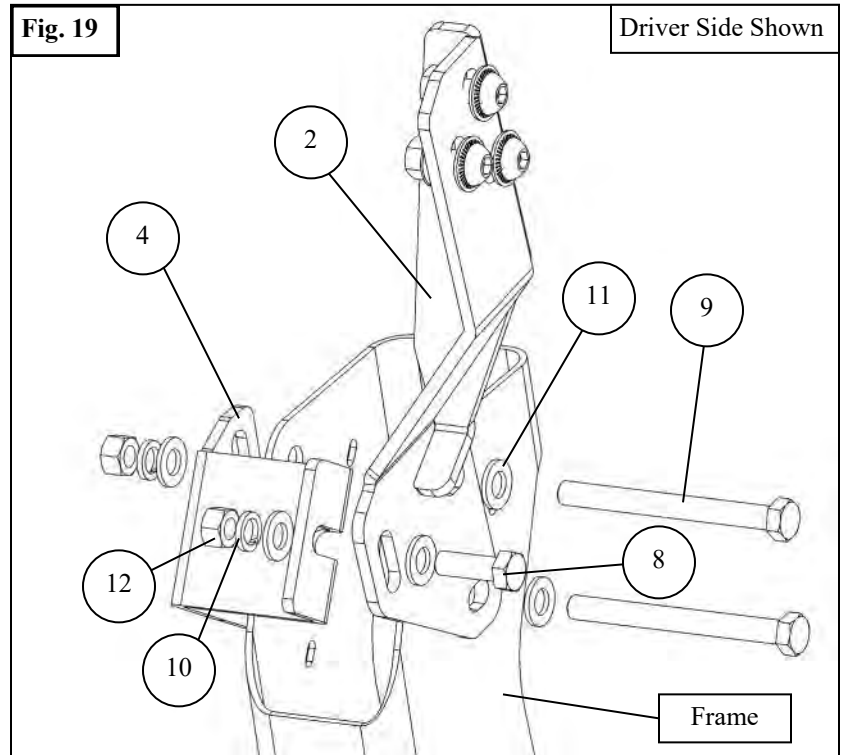
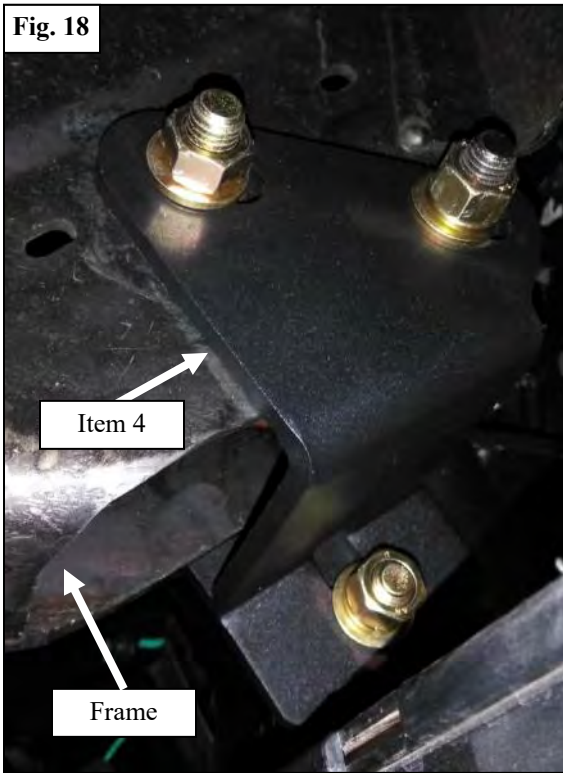

Bumper Valence Cutting Instructions 2020-2023

17. Locate the driver and passenger cutting templates (22-23). Starting on either side, along the template to the top corner of the valence. See **Figure 11**. Tape the template to the valence.
18. Using **Figures 20 & 21**, ensure that the measurements match your template. Follow the template instructions and cut accordingly. **Note: After cutting, you will still need to adjust your brackets and more cutting may be required!**

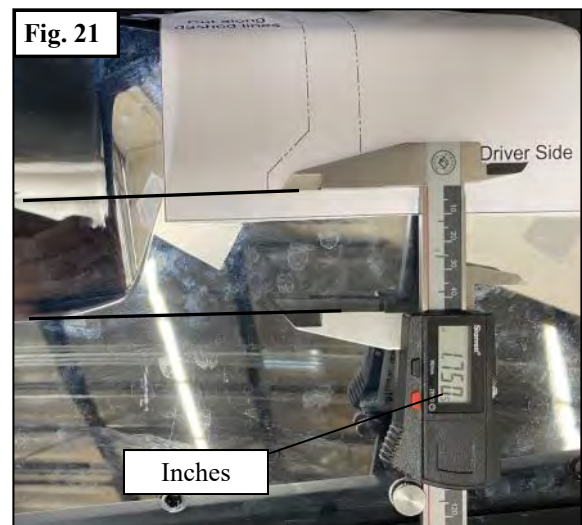
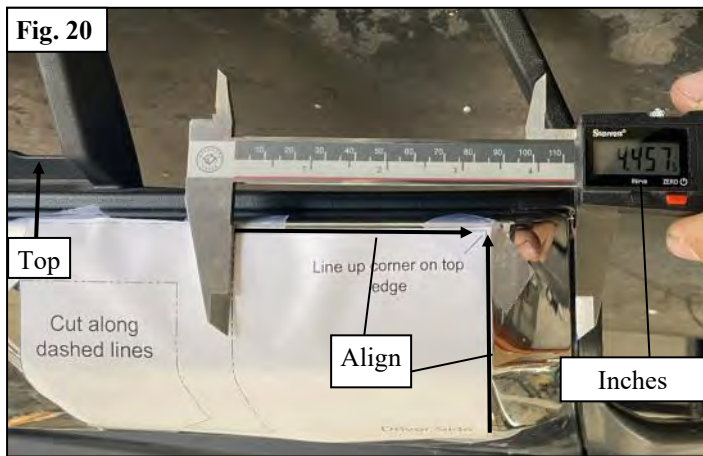

19. Locate the driver and passenger cutting templates “B” (19 & 20). Tape the driver side cutting template to the lower valence so that that the corner lines up with the edges shown below in **Figure 22**.
20. Repeat step 19 on the passenger side using the passenger cutting template “B”.
21. Using **Figure 22**, ensure that the measurements match your template. Follow the template instructions and cut accordingly.
Note: After cutting, you will still need to adjust your brackets and more cutting may be required!

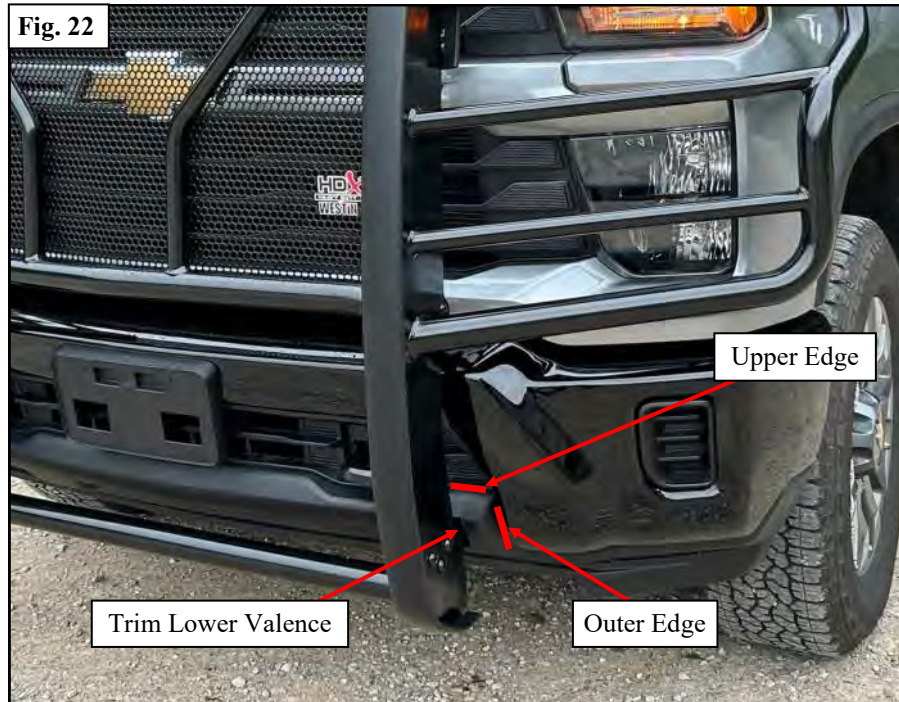

2020-2023 Upper Strap "A"

22. Locate the upper support straps "A" (6-7) for the grille guard. Loosely re-install the front bumper with the upper support straps. Reconnect all electrical connections. The upper factory bumper bolts will be used for the upper support straps. Measure the distance between the mounting surfaces of the upper straps and ensure it is about 42.25". Torque to 50-55 ft-lbs. See Figure 23 & 24.

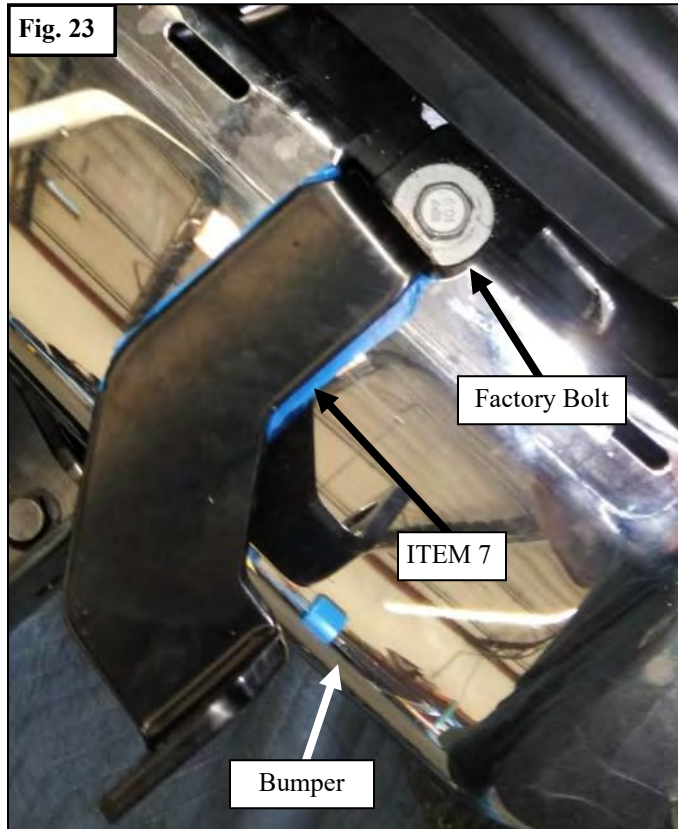

Fig. 24

42.25 inches



2024 Upper Strap "B"

23. Remove the plastic trim shown in **Figure 25**.
24. Locate the upper support straps "B" (items 36 and 37). Loosely re-install the front bumper with the upper support straps "B". Reconnect all electrical connections. The upper factory bumper bolts will be used for the upper support straps.
25. Cut the plastic trim removed in Step 22 so that the bolt can be accessed. The results should look like **Figure 25**.
26. Reinstall the plastic cover. See **Figure 25**.
27. Measure the distance between the mounting surfaces of the upper straps "B" and ensure it is about 42.25". Torque to 50-55 ft-lbs.

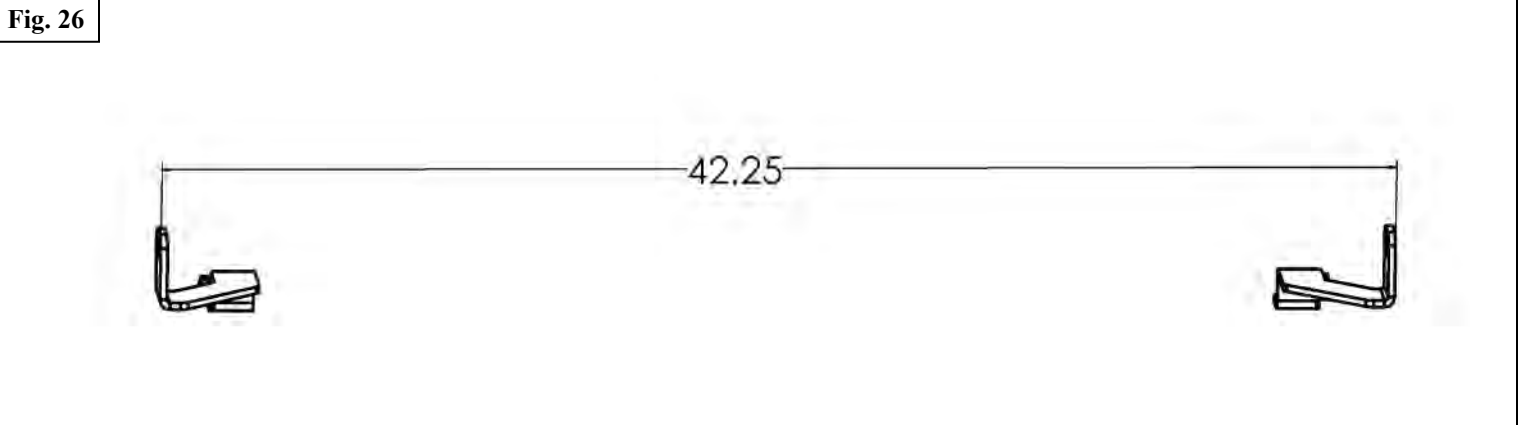

28. Reinstall the filler panel and grille.

29. With help, install the Grille Guard over the spacer blocks and previously installed upper support brackets. Using the supplied M10 and M12 hardware. See **Figures 27 & 28.**

30. Align as necessary and torque all hardware as specified: M12 to 50-55 ft-lbs., M10 to 30-35 ft-lbs.

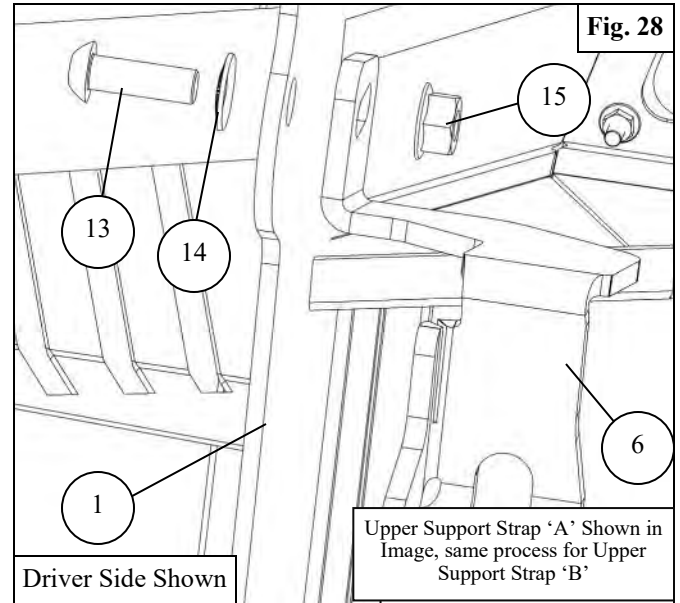
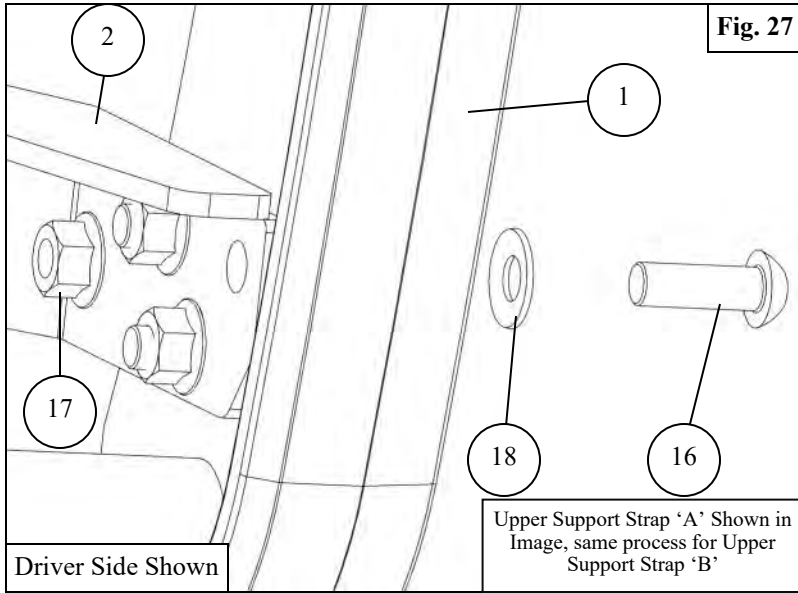

INSTALLATION COMPLETE



CARE INSTRUCTIONS

- REGULAR WAXING IS RECOMMENDED. DO NOT USE ANY TYPE OF POLISH OR WAX THAT MAY CONTAIN ABRASIVES.
- STAINLESS STEEL PRODUCTS CAN BE CLEANED WITH MILD SOAP AND WATER. STAINLESS STEEL POLISH SHOULD BE USED TO POLISH SMALL SCRATCHES.
- GLOSS BLACK FINISHES SHOULD BE CLEANED WITH MILD SOAP AND WATER.

WESTIN Westin Automotive Products, Inc.
320 W. Covina Blvd
San Dimas, Ca. 91773

Thank You for choosing Westin products
For Additional installation assistance please call
Customer service (800) 793-7846
www.westinautomotive.com



WARNING



Failure to follow these instructions could lead to death, personal injury, and / or property damage.

Failure to follow these instructions could lead to death, personal injury, and / or property damage.

FASTENERS:

All Westin supplied fasteners must be utilized and installed in accordance with the installation instructions and apply torque to the specifications as defined. **DOUBLE CHECK ALL FASTENERS BEFORE INITIAL USE, AND PERIODICALLY IN THE FUTURE TO ENSURE PROPER FUNCTION AND SAFETY.**

DRILLING:

Most Westin products do not require drilling for installation. If drilling is defined as required, use caution when drilling a vehicle. **FAILURE TO REVIEW AN AREA TO BE DRILLED MAY RESULT IN PERSONAL INJURY AND/OR INJURY TO OTHERS AS WELL AS VEHICLE DAMAGE.**

EYE PROTECTION:

ALWAYS WEAR SAFETY GLASSES OR GOGGLES DURING THE INSTALLATION PROCESS TO AVOID PERSONAL INJURY.

MAXIMUM TOWING/CARRYING CAPACITY: (if applicable)

The Westin Receiver Hitches will have a visible tow rating label affixed directly on the product. User should never exceed the vehicle manufacturers maximum tow and weight rating regardless of the capacity of the hitch. **FAILURE TO FOLLOW THESE GUIDELINES WILL VOID THE WESTIN WARRANTY AND MAY RESULT IN PERSONAL INJURY AND/OR INJURY TO OTHERS AS WELL AS VEHICLE DAMAGE.**

FOR CALIFORNIA RESIDENTS ONLY-PROP 65 WARNING:

Some products may contain chemicals such as DEHP, which can cause cancer, birth defects or other reproductive harm. For more info go to www.p65warnings.ca.gov



Westin Automotive Products, Inc.
320 W. Covina Blvd
San Dimas, Ca. 91773

Thank You for choosing Westin products
For Additional installation assistance please call
Customer service (800) 793-7846
www.westinautomotive.com