

INSTALLATION INSTRUCTIONS

OUTLAW FRONT BUMPER



APPLICATION:
2015-2019 Chevrolet Colorado
PART NUMBER:
58-61055

CONTENT			
ITEM	QUANTITY	DESCRIPTION	TOOLS NEEDED
1	1	BUMPER ASSEMBLY	16MM SOCKET
2	2	FRAME BRACKET (1 DRIVER, 1 PASSENGER)	16MM WRENCH
3	2	LED SLIDER BRACKET (1 DRIVER, 1 PASSENGER)	13MM SOCKET
4	2	LED L-BRACKET (1 DRIVER 1 PASSENGER)	13MM WRENCH
5	4	SQUARE LIGHT BRACKET	RATCHET
6	6	M10 HEX HEAD CAP SCREW	TORQUE WRENCH
7	12	M10 FLAT WASHER	CUTTING TOOL
8	6	M10 SPLIT LOCK WASHER	10MM SOCKET
9	6	M10 HEX NUT	18MM SOCKET
10	12	M8 CARRIAGE BOLT	18MM WRENCH
11	12	M8 HEX NUT	8MM SOCKET
12	16	M8 SPLIT LOCK WASHER	
13	12	SMALL M8 FLAT WASHER	
14	4	M8 BUTTON HEAD BOLT	
15	4	M8 SERRATED FLANGE NUT	
16	4	LARGE M8 FLAT WASHER	
17	4	M12 FLAT WASHER	
18	2	TRIM TEMPLATE (1 DRIVER, 1 PASSENGER)	

ANTI-SEIZE LUBRICANT MUST BE USED ON ALL STAINLESS STEEL FASTENERS TO PREVENT THREAD DAMAGE AND GALLING

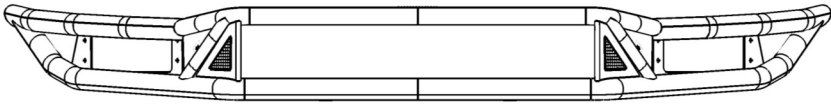

ITEM 1

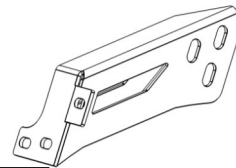

ITEM 2

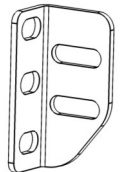

ITEM 3

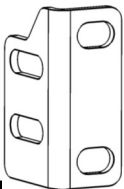

ITEM 4

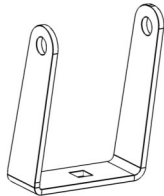

ITEM 5

PASSENGER SIDE ITEMS SHOWN;
DRIVER SIDE OPPOSITE WHERE APPLICABLE

PROCEDURE

1. Remove contents from box, verify if all parts listed are present and free from damage. Carefully read and understand all instructions before attempting installation.
Failure to identify damage before installation could lead to a rejection of any claim.

2. Remove the trim fasteners from the OEM fender liner. See **Figure 1**.
3. Disconnect any wire connections to the front bumper. See **Figure 2**.

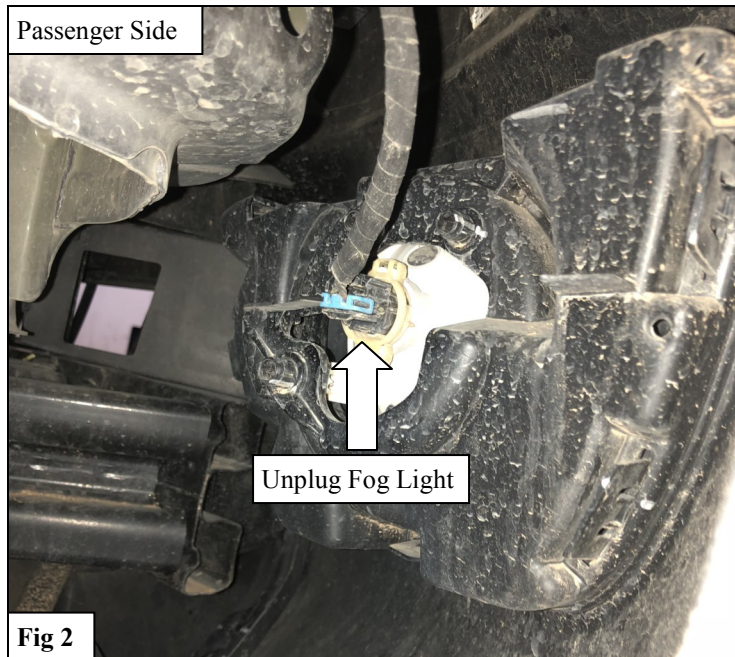
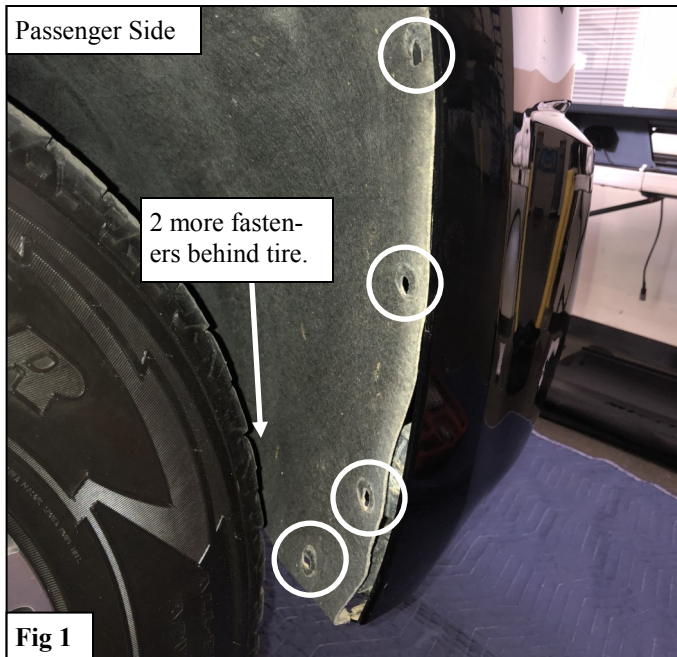

4. Remove the 3 bolts on each side behind the fender liner. See **Figure 3**.
5. Remove the 2 bolts on the front below the grille. See **Figure 4**.

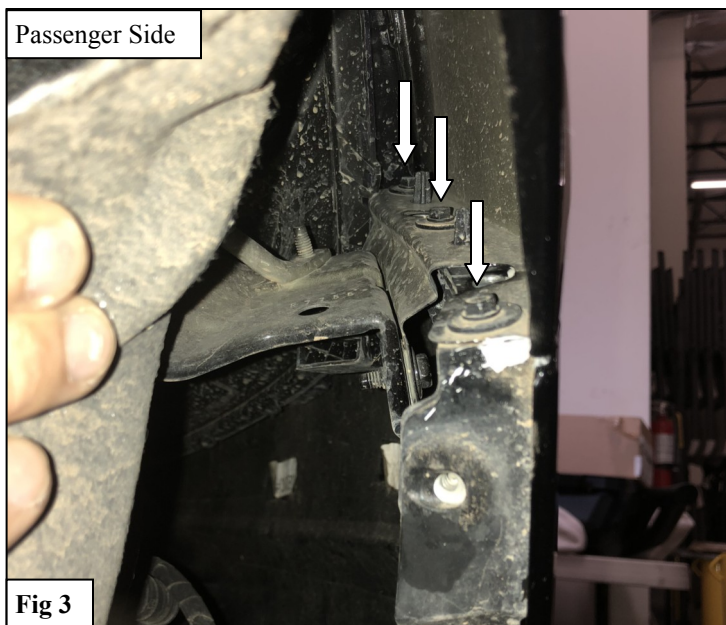

6. Open the hood and remove the 9 clips shown in **Figure 5**.
7. Remove the 6 bolts holding the grille to the vehicle. See **Figure 6**.

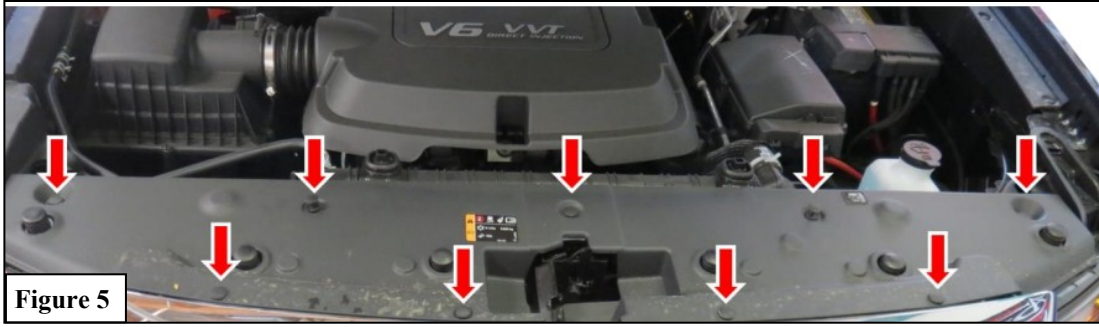

8. Gently pull the grille/bumper assembly to release it from the clips attaching it to the vehicle.
9. Remove the grille from the grille/bumper assembly. See **Figure 7**.
10. Remove the 2 bolts on either side that secure the reinforcement bar to the vehicle, and remove the bar. See **Figure 8**.

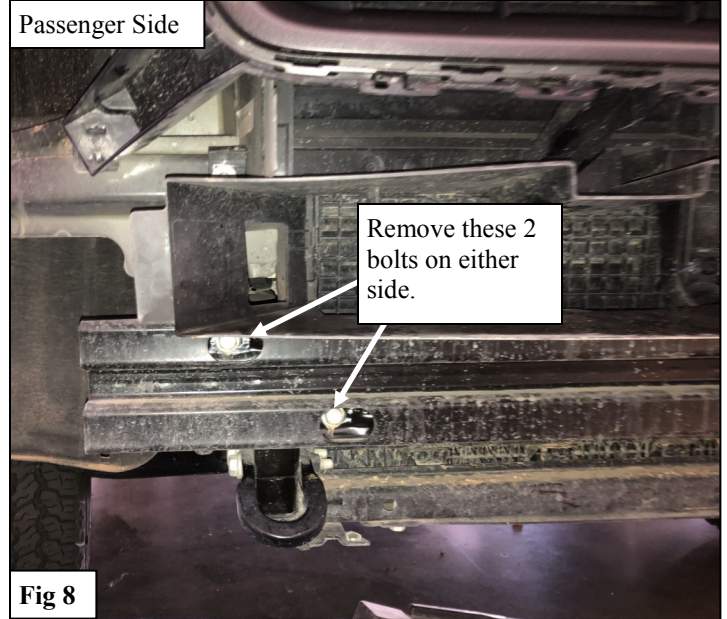
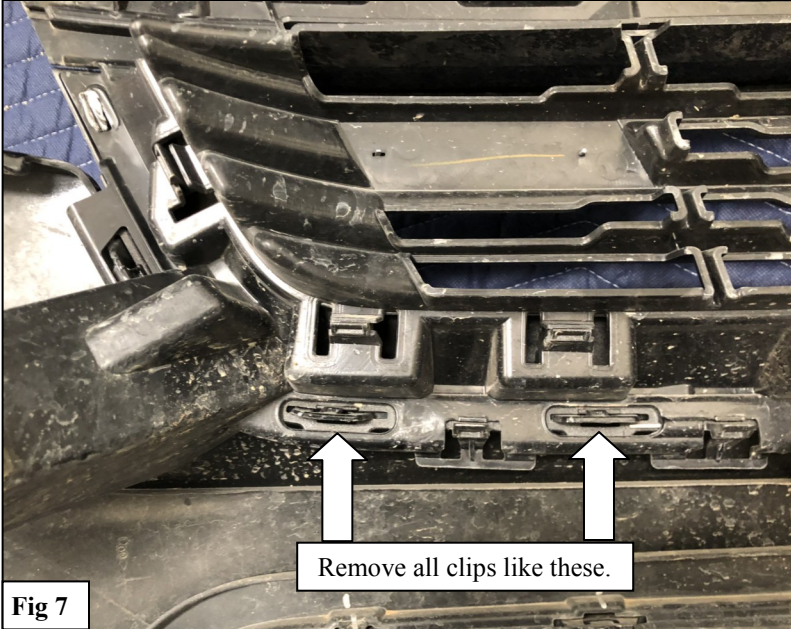

11. Remove the factory plate just below the tow hook on either side of the vehicle. See **Figure 9**.

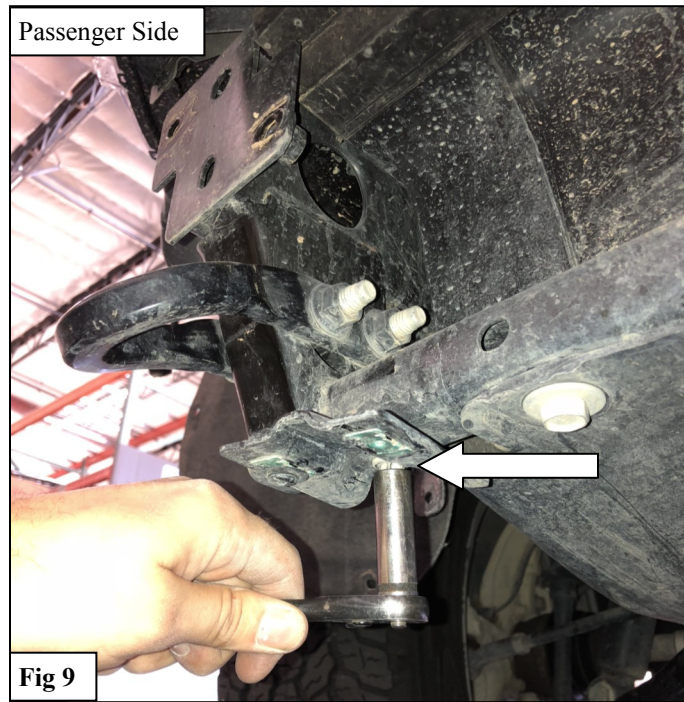

TRIMMING NEEDED OR OPTIONAL ZR2 PANEL INSTALLATION

- **Trimming of the factory bumper will be necessary to install the Outlaw Front Bumper**
- **If you would not like to trim the bumper, the Colorado ZR2 part numbers 84119762 & 84119761 may be purchased separately and installed. These panels will also allow for the installation of the bumper.**
- **ONLY ONE OPTION IS NEEDED: YOU MAY EITHER TRIM THE OEM BUMPER OR PURCHASE THE ZR2 PANELS SEPARATELY**

Optional ZR2 Panel Installation

1. Remove the trim piece from the OEM Bumper and trim it as indicated in **Figure 10-12**.

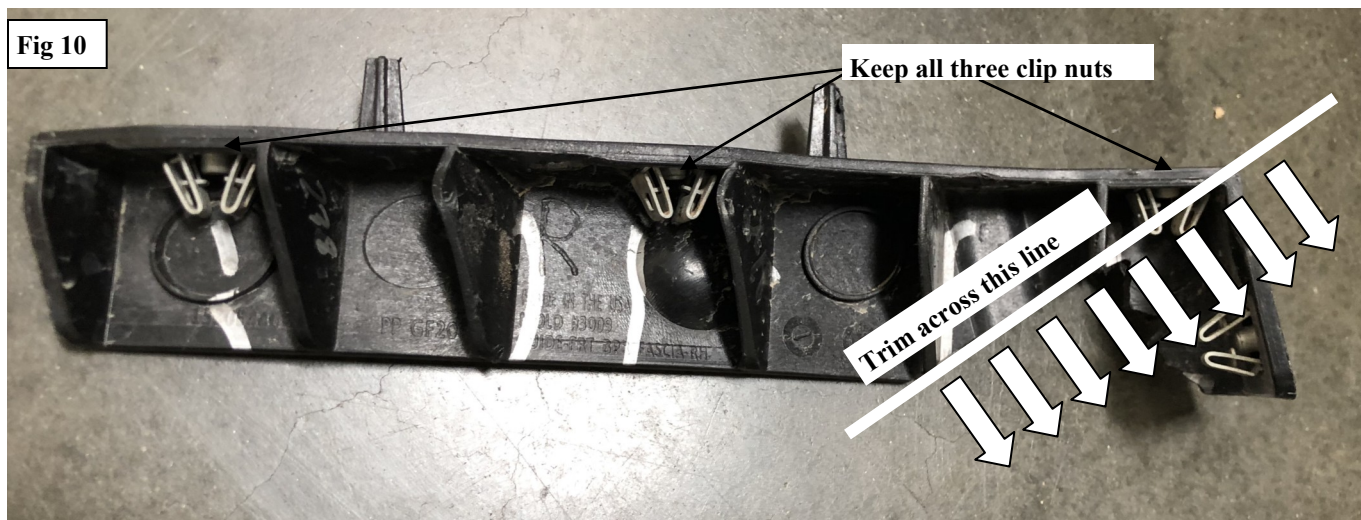

Westin Automotive Products, Inc.
320 W. Covina Blvd
San Dimas, Ca. 91773

Thank you for choosing Westin products
for additional installation assistance please call
Customer Service (800) 793-7846

www.westinautomotive.com

Figure 11

Passenger Side

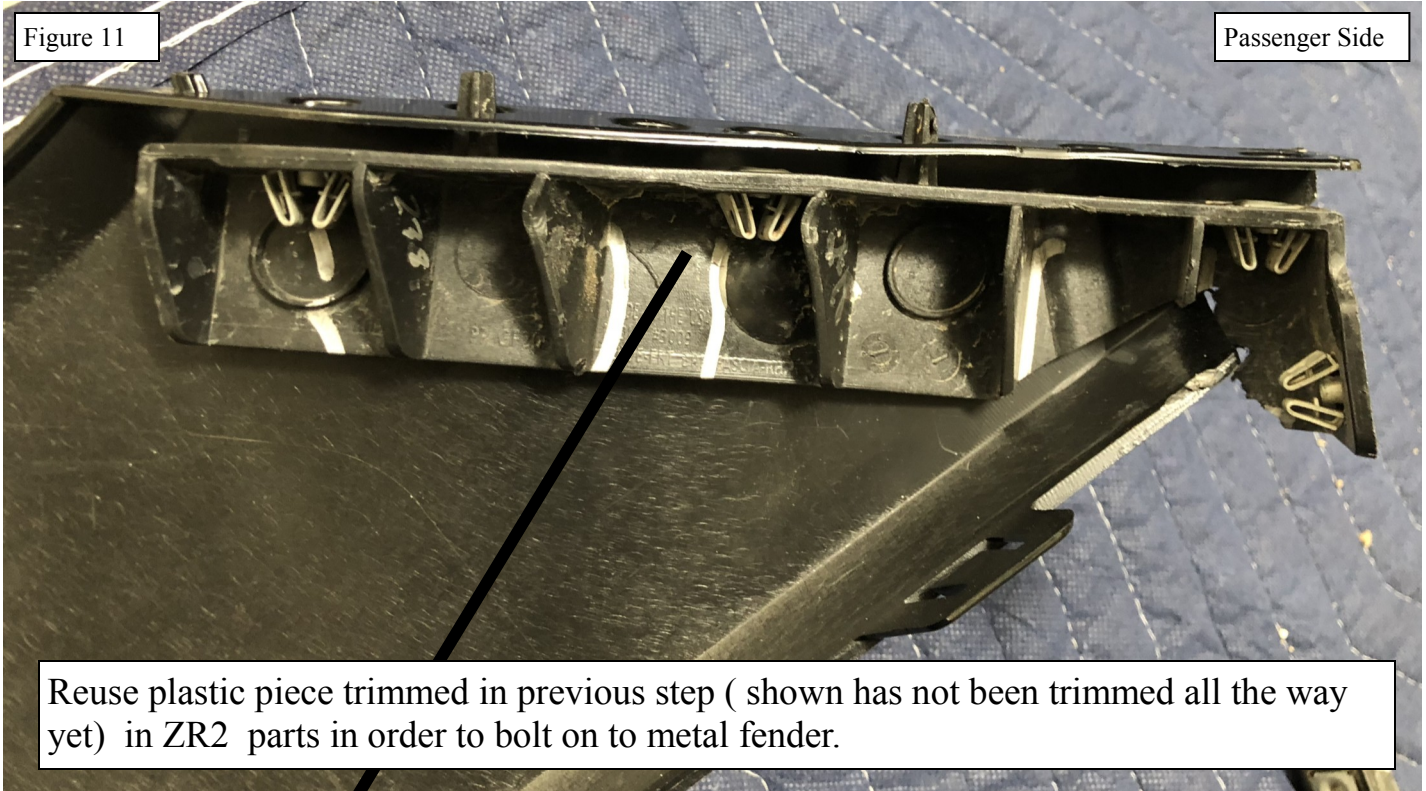

Reuse plastic piece trimmed in previous step (shown has not been trimmed all the way yet) in ZR2 parts in order to bolt on to metal fender.

Figure 12



2. Reinstall the OEM Grille as removed in **Steps 6 & 7**.
3. Install the ZR2 Panel with the trim piece as removed in **Step 4** using the factory hardware.
4. The other end of the ZR2 Panel may be attached to the OEM Grille using zip ties if necessary . See **Figure 13**.

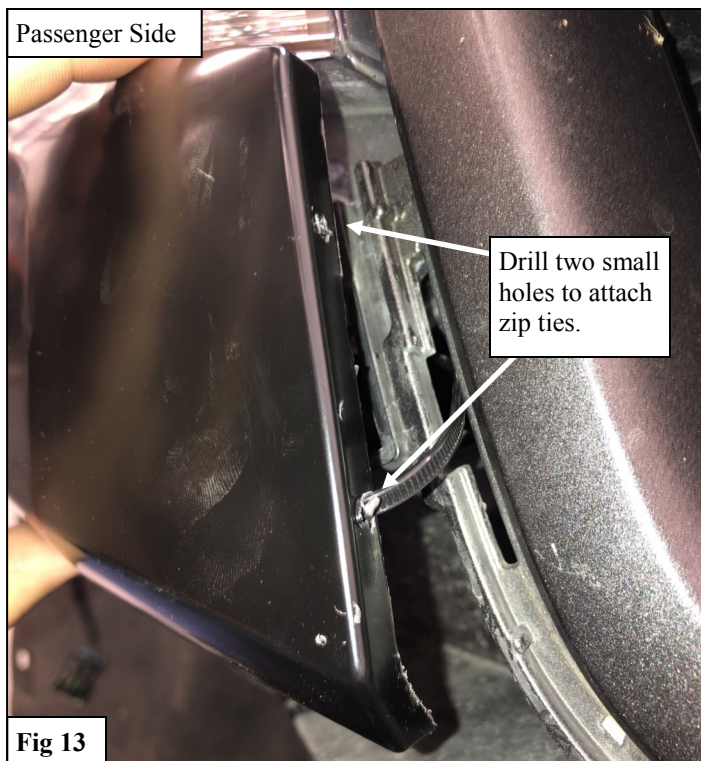

OEM Panel Trimming Process (only needed if not using ZR2 Panels)

1. Refer to **Figure 14-16**. Trim the OEM Bumper using the supplied template as indicated. *Note: It is always better to trim a little at a time to ensure that too much material is not removed.*
2. Repeat this process for both sides.

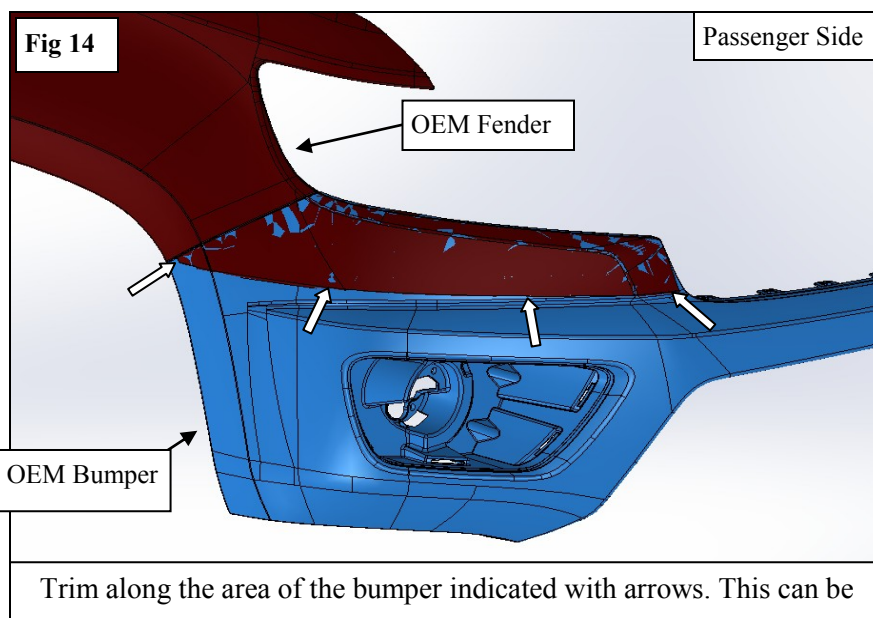

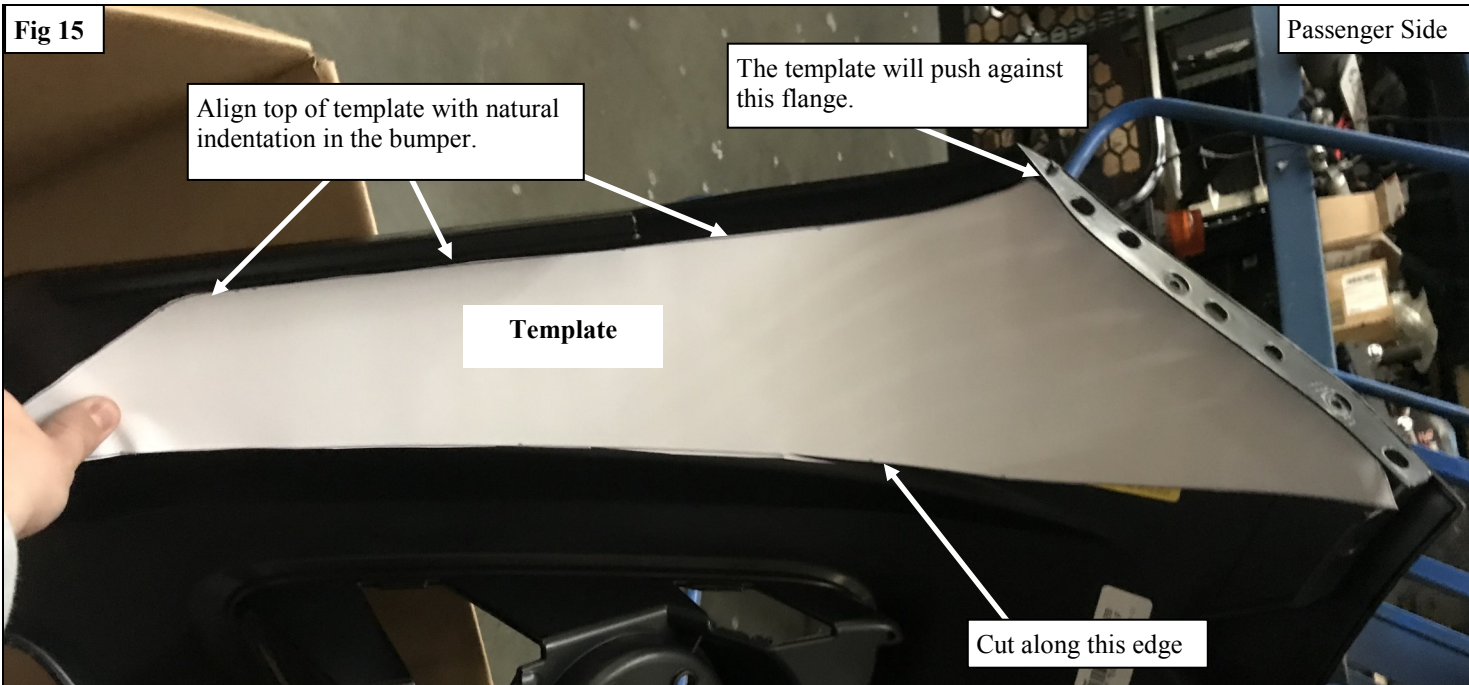

Align the Template (18) with its corresponding features on the bumper. *Note: The cut will not follow the natural contour of the bumper. Follow the template as close as possible.*

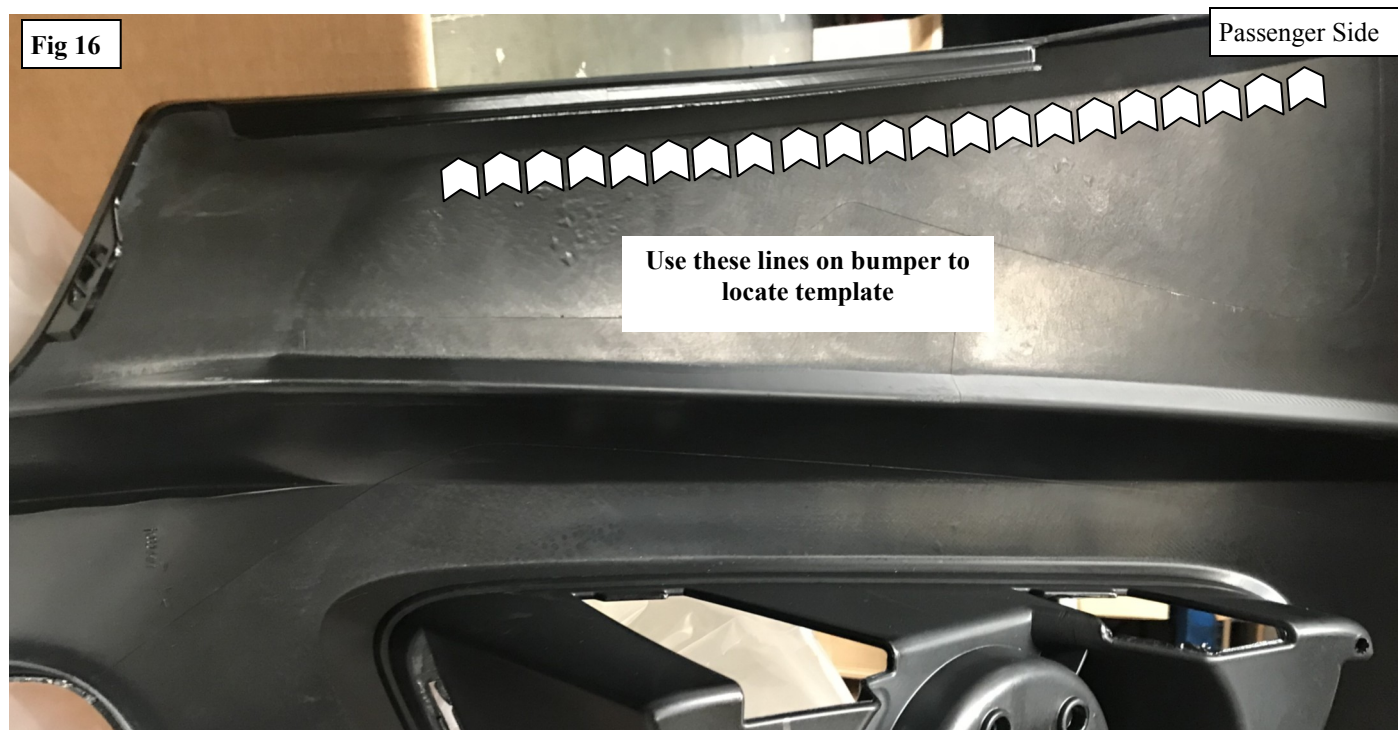

Outlaw Front Bumper Installation

1. Use the hardware removed in **Step 10** and **M12 washers** included (**Item 17**) to install the **Frame Brackets (2)**. See **Figures 17 & 18**.

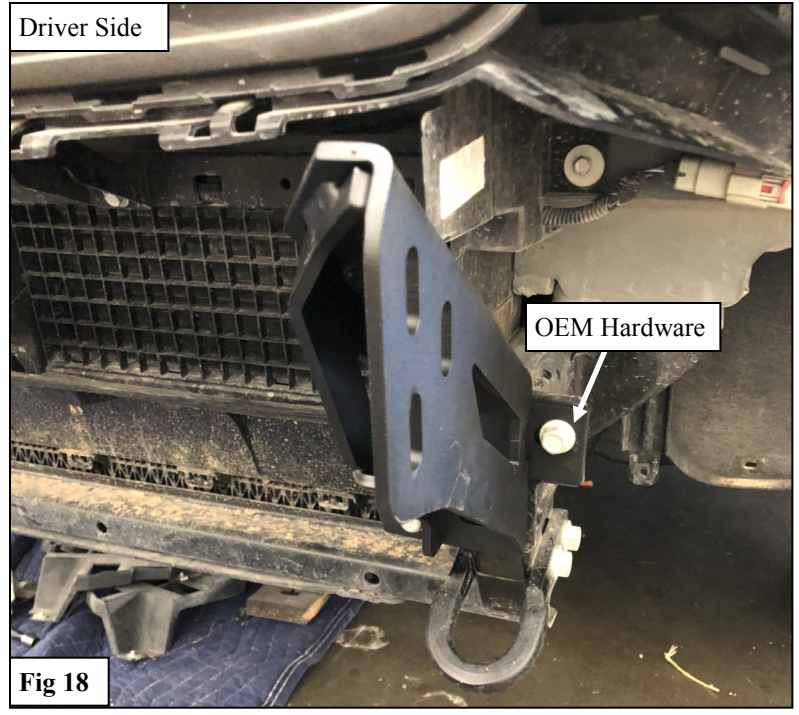
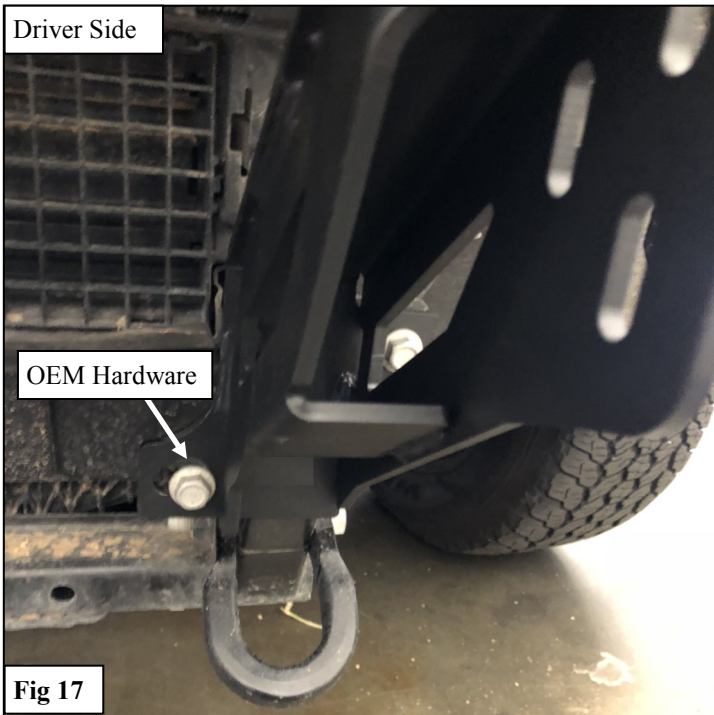

2. Attach the **Outlaw Front Bumper (1)** using the supplied **M10 Hardware**. See **Figures 19 & 20**.

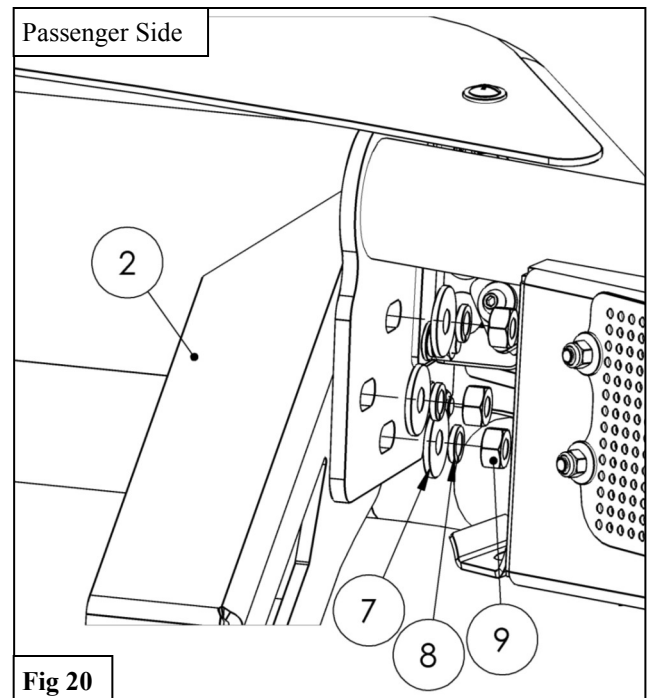
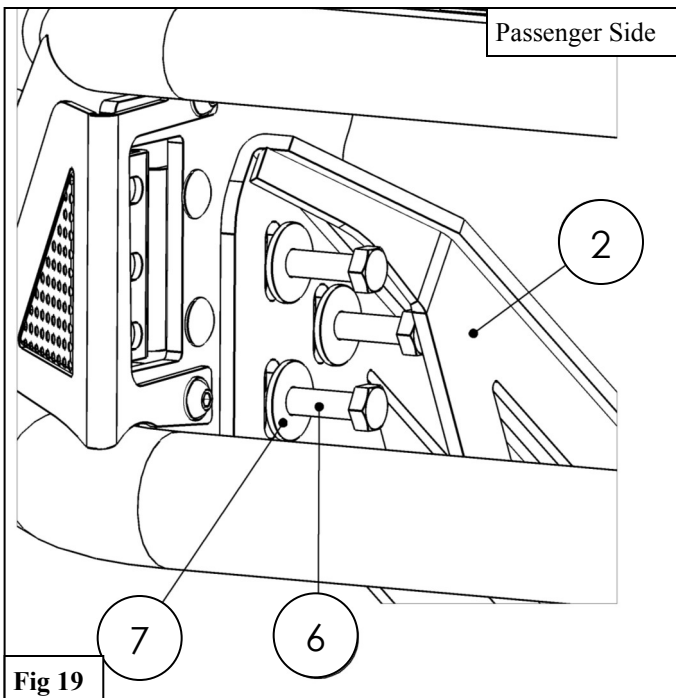

3. Proceed to install center light bar brackets and light bar (s). The LED brackets (3-4) can be mounted in different configurations in order to have the necessary adjustment for various “30” inch light bar overall lengths. See **Figure 21-23**.
Note: Lights sold separately.

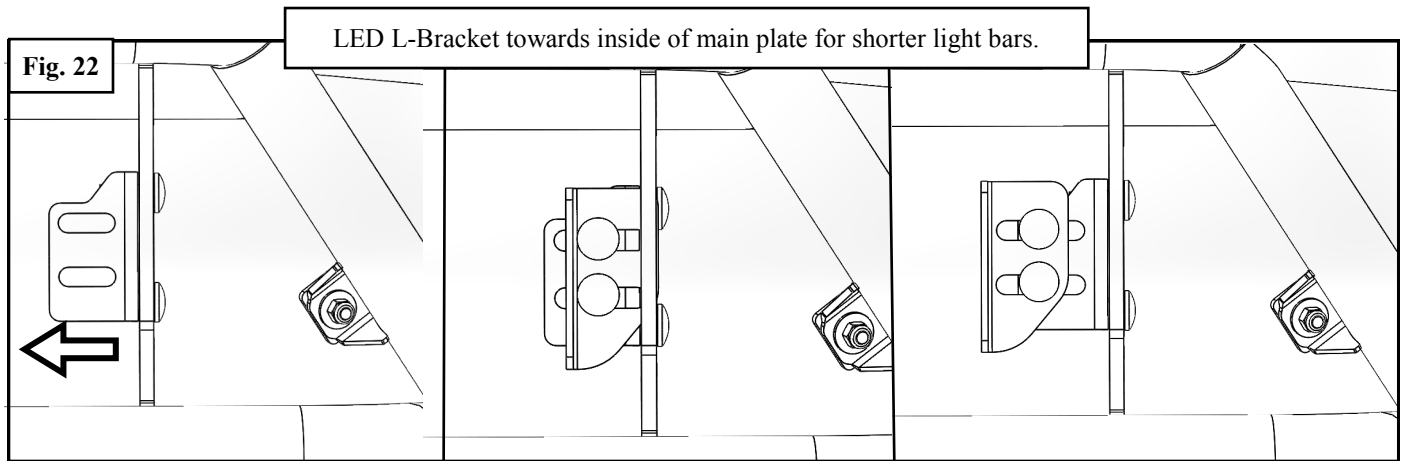
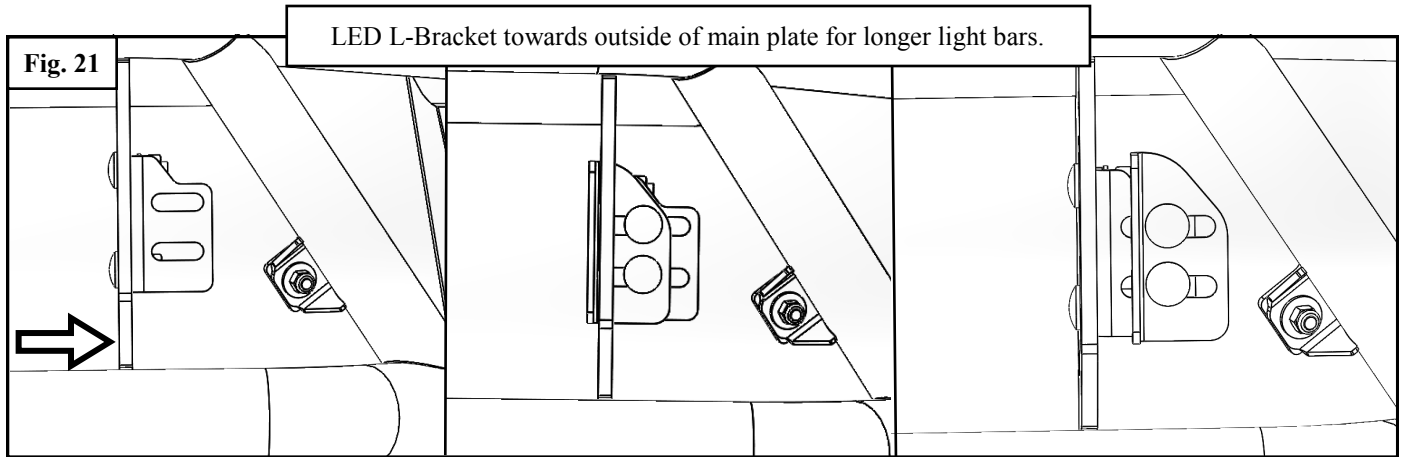
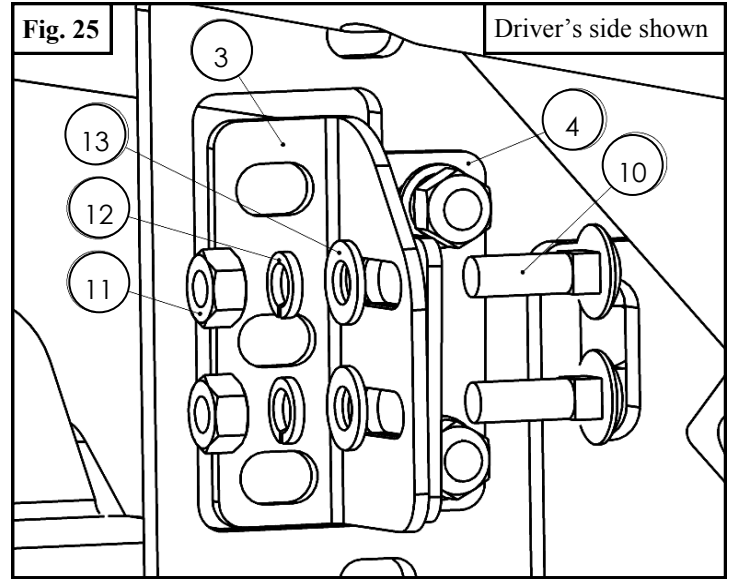
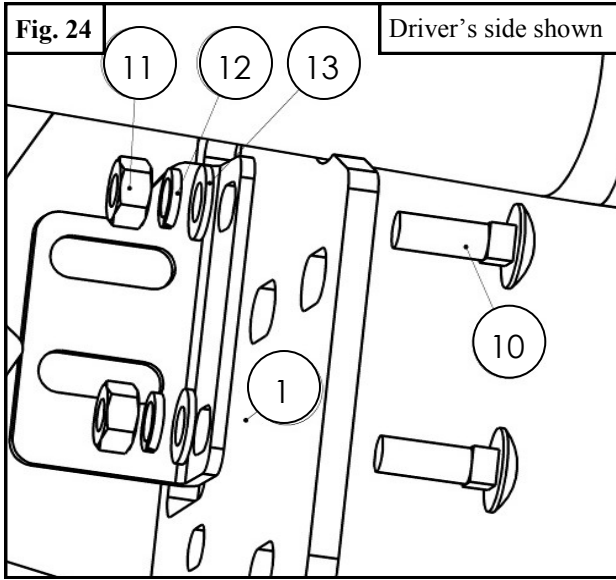
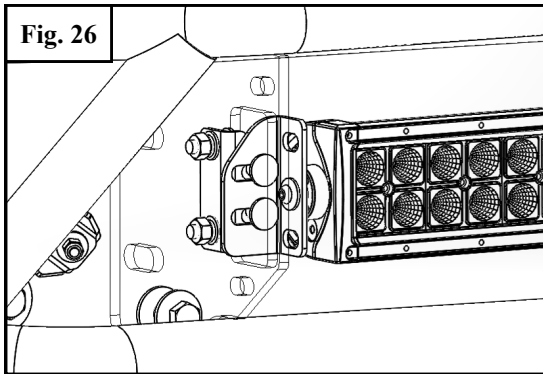

Figure 23 is an example showing the LED brackets adjusted in for the shortest light bar configuration.

4. Using the supplied M8 hardware, loosely fasten LED L-Brackets (4) to main plate. See **Figure 24**.
5. Using the supplied M8 hardware, loosely fasten LED Slider Bracket (3) to LED L-Bracket. See **Figure 25**.



6. Using hardware included in the LED light bar kit, fasten light bar to slider brackets according to **Figures 26 & 27**.
7. Position light bar as desired and tighten all M8 hardware to 15-18 ft-lbs.



Single "Double Row" Light Bar Configuration

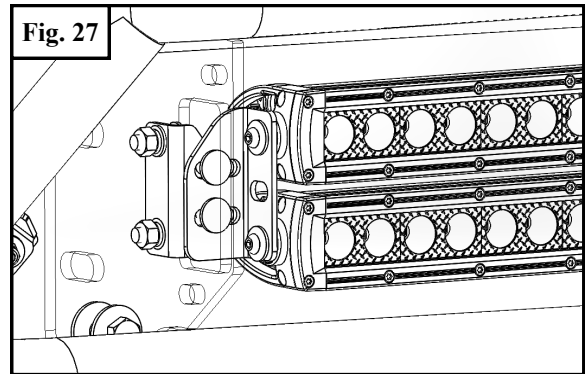

Double "Single Row" Light Bar Configuration

8. Position the meshed corner covers as seen in **Figures 28 & 29**.

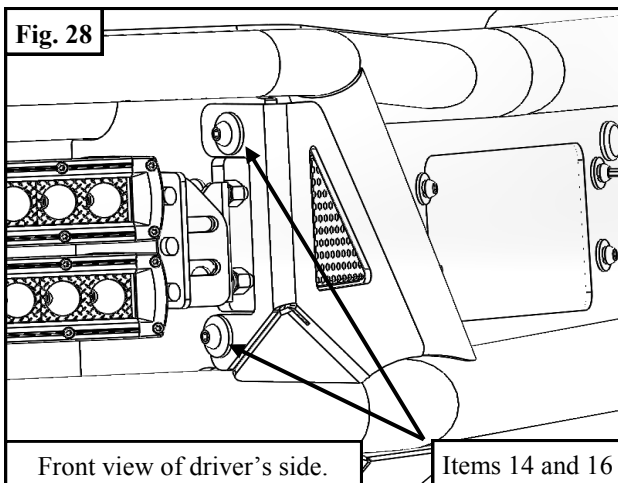

Front view of driver's side.

Items 14 and 16

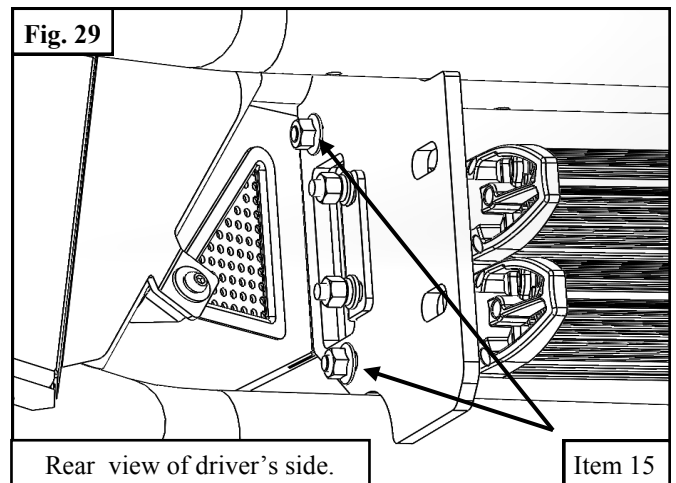

Rear view of driver's side.

Item 15



Westin Automotive Products, Inc.
320 W. Covina Blvd
San Dimas, Ca. 91773

Thank you for choosing Westin products
for additional installation assistance please call
Customer Service (800) 793-7846

www.westinautomotive.com

DATE: 12/10/18

9. If using LED cube lights, install the Square Light Brackets as shown in **Figures 30 & 31** using the supplied M8 Hardware.
Note: only Westin Part #'s 09-12205A-PR, 09-12200A-PR, & 09-12200B-PR will work with these brackets.

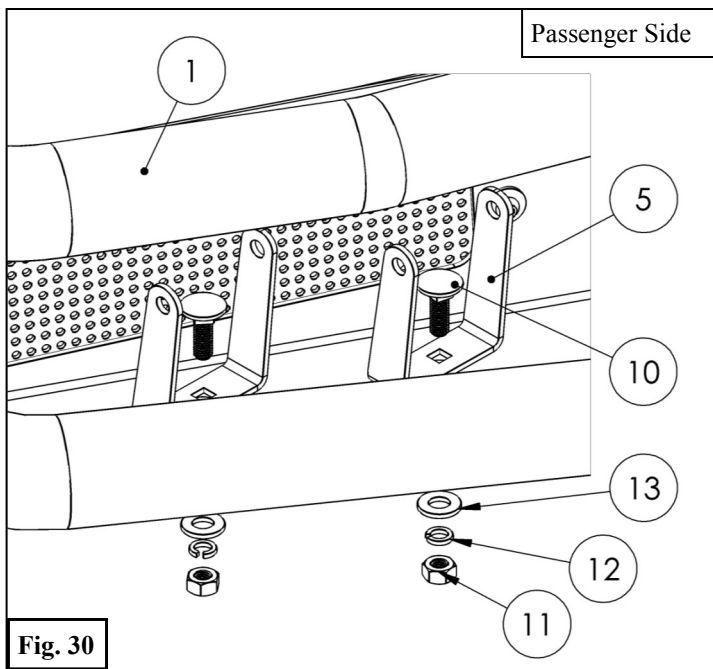

When installing cube lights, remove the mounting bracket supplied with the lights and install the light to the Square Bracket as shown.

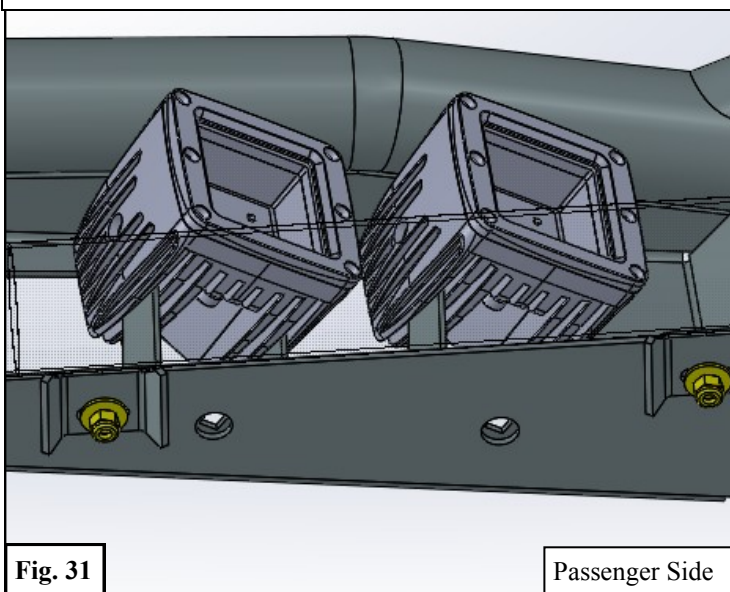

Installation Complete

Skid Plate and Lights Sold Separately



CARE INSTRUCTIONS

- REGULAR WAXING IS RECOMMENDED. DO NOT USE ANY TYPE OF POLISH OR WAX THAT MAY CONTAIN ABRASIVES.
- STAINLESS STEEL PRODUCTS CAN BE CLEANED WITH MILD SOAP AND WATER. STAINLESS STEEL POLISH SHOULD BE USED TO POLISH SMALL SCRATCHES.
- GLOSS BLACK FINISHES SHOULD BE CLEANED WITH MILD SOAP AND WATER

WESTIN Westin Automotive Products, Inc.
 320 W. Covina Blvd
 San Dimas, Ca. 91773

Thank you for choosing Westin products
 for additional installation assistance please call
 Customer Service (800) 793-7846
 www.westinautomotive.com



WARNING



Failure to follow these instructions could lead to death, personal injury, and / or property damage.

Failure to follow these instructions could lead to death, personal injury, and / or property damage.

FASTENERS:

All Westin supplied fasteners must be utilized and installed in accordance with the installation instructions and apply torque to the specifications as defined. **DOUBLE CHECK ALL FASTENERS BEFORE INITIAL USE, AND PERIODICALLY IN THE FUTURE TO ENSURE PROPER FUNCTION AND SAFETY.**

DRILLING:

Most Westin products do not require drilling for installation. If drilling is defined as required, use caution when drilling a vehicle. **FAILURE TO REVIEW AN AREA TO BE DRILLED MAY RESULT IN PERSONAL INJURY AND/OR INJURY TO OTHERS AS WELL AS VEHICLE DAMAGE.**

EYE PROTECTION:

ALWAYS WEAR SAFETY GLASSES OR GOGGLES DURING THE INSTALLATION PROCESS TO AVOID PERSONAL INJURY.

MAXIMUM TOWING/CARRYING CAPACITY: (if applicable)

The Westin Receiver Hitches will have a visible tow rating label affixed directly on the product. User should never exceed the vehicle manufacturers maximum tow and weight rating regardless of the capacity of the hitch. **FAILURE TO FOLLOW THESE GUIDELINES WILL VOID THE WESTIN WARRANTY AND MAY RESULT IN PERSONAL INJURY AND/OR INJURY TO OTHERS AS WELL AS VEHICLE DAMAGE.**

FOR CALIFORNIA RESIDENTS ONLY-PROP 65 WARNING:

Some products may contain chemicals such as DEHP, which can cause cancer, birth defects or other reproductive harm. For more info go to www.p65warnings.ca.gov



Westin Automotive Products, Inc.
320 W. Covina Blvd
San Dimas, Ca. 91773